

## Motor management - EMM 3- 24DC/500AC-16-IFS - 2297523

Please be informed that the data shown in this PDF Document is generated from our Online Catalog. Please find the complete data in the user's documentation. Our General Terms of Use for Downloads are valid (<http://phoenixcontact.com/download>)



Electronic motor management with integrated current transformers up to 16 A - active power measurement for overload and underload monitoring of motors and systems for optimum protection. Freely parameterizable switching and signaling thresholds.

### Product Features

- Optional connection to INTERFACE system and PROFIBUS-GATEWAY-IFS via TBUS
- Digital outputs control external switching elements
- Freely parameterizable signaling or switching thresholds



### Key commercial data

Packing unit	1 pc
Weight per Piece (excluding packing)	240.0 GRM
Custom tariff number	85371099
Country of origin	Germany

### Technical data

#### Note

Utilization restriction	EMC: class A product, see manufacturer's declaration in the download area
-------------------------	---

#### Dimensions

Width	22.5 mm
Height	99 mm
Depth	114.5 mm

#### Ambient conditions

Ambient temperature (operation)	-25 °C ... 70 °C
Ambient temperature (storage/transport)	-25 °C ... 70 °C
Degree of protection	IP20

# Motor management - EMM 3- 24DC/500AC-16-IFS - 2297523

## Technical data

### Input data

Input name	Device supply
Rated control supply voltage $U_S$	24 V DC
Voltage range with reference to $U_S$	0.8 ... 1.25
Rated control supply current $I_S$	25 mA
Switching threshold "0" signal, voltage	9.6 V DC
Switching threshold "1" signal voltage	19.2 V DC
Operating voltage display	Green LED
Status display	LED yellow right rotation (R), LED yellow left rotation (L), LED green data communication
Indication	Red LED
Input name	Digital inputs (IN1 - IN4)
Rated actuating voltage $U_C$	24 V DC
Rated actuating current $I_C$	3.3 mA
Input name	Voltage measuring input V1, V2, V3
	Current measuring input L1/T1, L2/T2, L3/T3
Typical input current at $U_N$	max. 16 A

### Output data

Output name	Acknowledging contacts O1-O4
Note	The meaning of the acknowledgement outputs can be freely parameterized, see user manual
Number of outputs	4
Nominal output voltage	24 V DC (semiconductor output)
Nominal output voltage range (factor)	0.8 ... 1.25
Continuous load current	500 mA
Residual voltage	< 200 mV
Protective circuit/component	Suppressor diode
Surge voltage protection	> 33 V DC

### Output data, signaling contact

Designation	Current measurement
Measuring via	Internal current transformer
Basic accuracy	typ. 0.5 %
Designation	Voltage measurement/phase-to-neutral voltage
Voltage range	0 V AC ... 350 V AC (Phase-to-neutral voltage)
Basic accuracy	typ. 0.75 %
Designation	Power measurement
Basic accuracy	typ. 2 %

# Motor management - EMM 3- 24DC/500AC-16-IFS - 2297523

## Technical data

### Connection data

Connection method	Screw connection
Conductor cross section solid min.	0.14 mm <sup>2</sup>
Conductor cross section solid max.	2.5 mm <sup>2</sup>
Conductor cross section stranded min.	0.14 mm <sup>2</sup>
Conductor cross section stranded max.	2.5 mm <sup>2</sup>
Conductor cross section AWG/kcmil min.	26
Conductor cross section AWG/kcmil max	12

### General

Test voltage input/output	8 kV
Mounting position	Vertical (horizontal DIN rail)
Assembly instructions	In rows with zero spacing
Operating mode	100% operating factor
Designation	Low voltage switching device
Standards/regulations	EN 60947
	EN 60947-4-2
Designation	Power station requirements
Standards/regulations	DWR 1300 / ZXX01/DD/7080.8d
Designation	Noise immunity
Standards/regulations	EN 61000-6-2
	EN 61000-6-3
	EN 61000-6-4
Rated surge voltage / insulation	6 kV/safe isolation
Rated insulation voltage	500 V
Pollution degree	2
Surge voltage category	III

## Classifications

### eCl@ss

eCl@ss 4.0	27371102
eCl@ss 4.1	27371102
eCl@ss 5.0	27371601
eCl@ss 5.1	27371601
eCl@ss 6.0	27371601
eCl@ss 7.0	27371601
eCl@ss 8.0	27371601

# Motor management - EMM 3- 24DC/500AC-16-IFS - 2297523

## Classifications

### ETIM

ETIM 2.0	EC000066
ETIM 3.0	EC000066
ETIM 4.0	EC000066
ETIM 5.0	EC001437

### UNSPSC

UNSPSC 6.01	30211915
UNSPSC 7.0901	39121514
UNSPSC 11	39121514
UNSPSC 12.01	39121514
UNSPSC 13.2	39121514

## Approvals

### Approvals

---

#### Approvals

UL Listed / cUL Listed / cULus Listed

---

#### Ex Approvals

ATEX

---

#### Approvals submitted

---

### Approval details

UL Listed 
---

cUL Listed 
--

# Motor management - EMM 3- 24DC/500AC-16-IFS - 2297523

Approvals



## Drawings

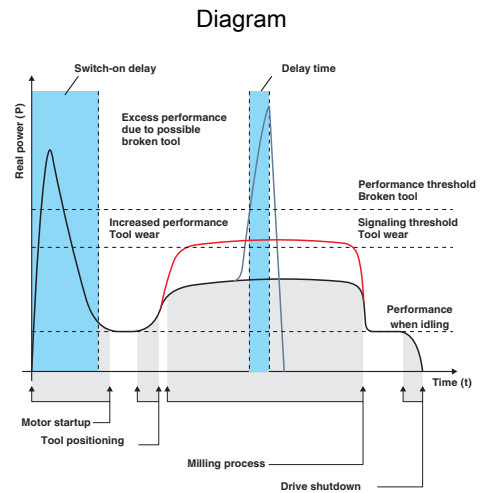
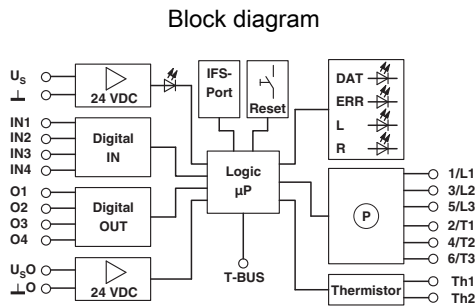

Status monitoring: machine tool for milling

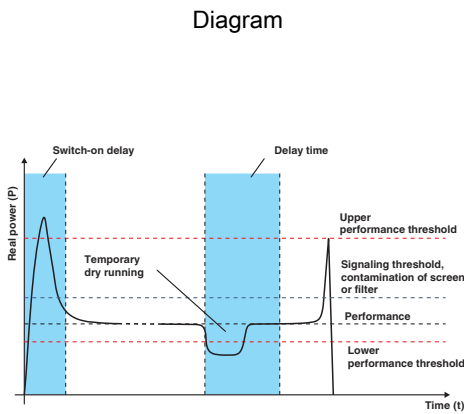

Status monitoring: air bubbles in motor-operated pumps

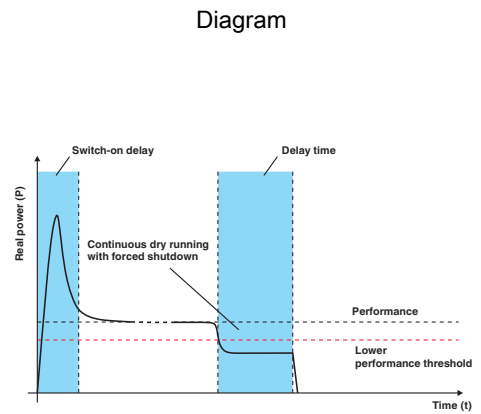

Status monitoring: dry run in motor-operated pumps

# Motor management - EMM 3- 24DC/500AC-16-IFS - 2297523

Connection diagram

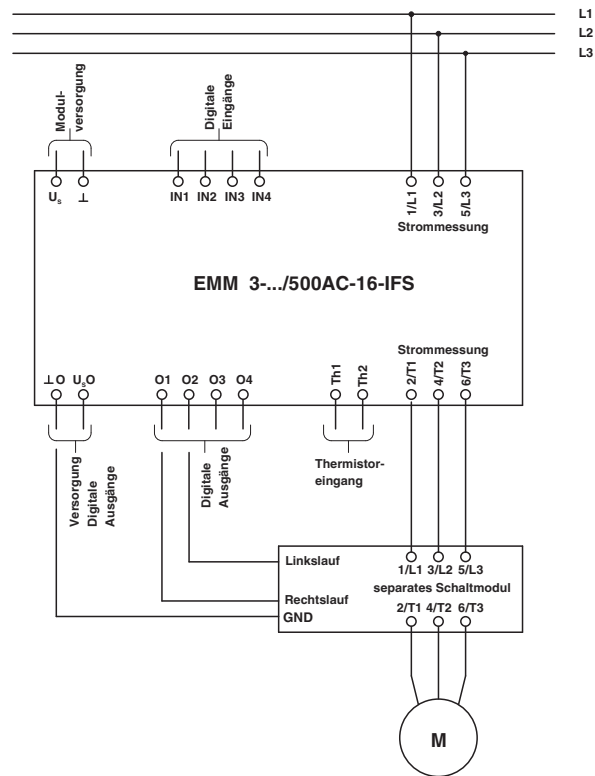

## Данный компонент на территории Российской Федерации

### Вы можете приобрести в компании MosChip.

Для оперативного оформления запроса Вам необходимо перейти по данной ссылке:

<http://moschip.ru/get-element>

Вы можете разместить у нас заказ для любого Вашего проекта, будь то серийное производство или разработка единичного прибора.

В нашем ассортименте представлены ведущие мировые производители активных и пассивных электронных компонентов.

Нашей специализацией является поставка электронной компонентной базы двойного назначения, продукции таких производителей как XILINX, Intel (ex.ALTERA), Vicor, Microchip, Texas Instruments, Analog Devices, Mini-Circuits, Amphenol, Glenair.

Сотрудничество с глобальными дистрибьюторами электронных компонентов, предоставляет возможность заказывать и получать с международных складов практически любой перечень компонентов в оптимальные для Вас сроки.

На всех этапах разработки и производства наши партнеры могут получить квалифицированную поддержку опытных инженеров.

Система менеджмента качества компании отвечает требованиям в соответствии с ГОСТ Р ИСО 9001, ГОСТ РВ 0015-002 и ЭС РД 009

### Офис по работе с юридическими лицами:

105318, г.Москва, ул.Щербаковская д.3, офис 1107, 1118, ДЦ «Щербаковский»

Телефон: +7 495 668-12-70 (многоканальный)

Факс: +7 495 668-12-70 (доб.304)

E-mail: [info@moschip.ru](mailto:info@moschip.ru)

Skype отдела продаж:

moschip.ru

moschip.ru\_4

moschip.ru\_6

moschip.ru\_9