

# PTAB182002FC

## Thermally-Enhanced High Power RF LDMOS FET 190 W, 28 V, 1805 – 1880 MHz

### Description

The PTAB182002FC is a 190-watt LDMOS FET intended for use in multi-standard cellular power amplifier applications in the 1805 to 1880 MHz frequency band. Features include input and output matching, high gain and thermally-enhanced package with earless flange. Manufactured with Wolfspeed's advanced LDMOS process, this device provides excellent thermal performance and superior reliability.

PTAB182002FC  
Package H-37248-4

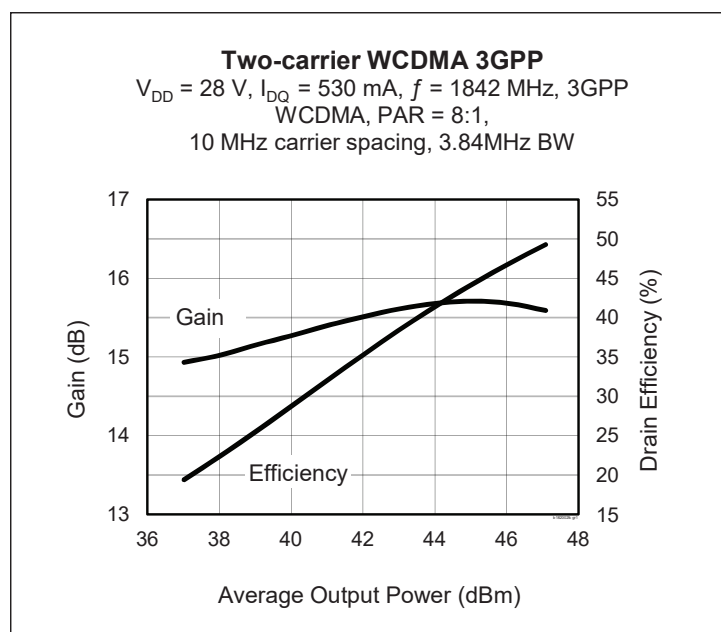

### Features

- Asymmetric Doherty design
  - Main:  $P_{1dB} = 70\text{ W Typ}$
  - Peak:  $P_{1dB} = 120\text{ W Typ}$
- Broadband internal matching
- Typical two-carrier WCDMA performance at 1842 MHz, 28 V (Doherty configuration)
  - Average output power = 44.6 dBm
  - Linear Gain = 15.5 dB
  - Efficiency = 46%
  - IMD = -25 dBc
- Increased negative gate-source voltage range for improved performance in Doherty amplifiers
- Integrated ESD protection
- Capable of handling 3:1 VSWR @ 30 V, 50 W (average) output power (one-carrier WCDMA signal, 10 dB PAR, Doherty test fixture)
- Pb-free and RoHS-compliant

### RF Characteristics

#### Two-carrier WCDMA Measurements (tested in Wolfspeed Doherty test fixture)

$V_{DD} = 28\text{ V}$ ,  $V_{GSPK} = (V_{GS}\text{ at } I_{DQ} = 900\text{ mA}) - 1.80\text{ V}$ ,  $I_{DQ} = 520\text{ mA}$ ,  $P_{OUT} = 29\text{ W avg.}$ ,  $f_1 = 1870\text{ MHz}$ ,  $f_2 = 1880\text{ MHz}$ , 7.5 dB PAR

Characteristic	Symbol	Min	Typ	Max	Unit
Gain	$G_{ps}$	14.5	15.5	—	dB
Drain Efficiency	$\eta_D$	42	44	—	%
Intermodulation Distortion	IMD	—	-26.5	-24	dBc

All published data at  $T_{CASE} = 25^\circ\text{C}$  unless otherwise indicated

ESD: Electrostatic discharge sensitive device—observe handling precautions!

## DC Characteristics

Characteristic	Conditions	Symbol	Min	Typ	Max	Unit
Drain-source Breakdown Voltage	$V_{GS} = 0\text{ V}, I_{DS} = 10\text{ mA}$	$V_{(BR)DSS}$	65	—	—	V
Drain Leakage Current	$V_{DS} = 28\text{ V}, V_{GS} = 0\text{ V}$	$I_{DSS}$	—	—	1.0	$\mu\text{A}$
	$V_{DS} = 63\text{ V}, V_{GS} = 0\text{ V}$	$I_{DSS}$	—	—	10.0	$\mu\text{A}$
On-state Resistance (main)	$V_{GS} = 10\text{ V}, V_{DS} = 0.1\text{ V}$	$R_{DS(on)}$	—	0.15	—	$\Omega$
On-state Resistance (peak)	$V_{GS} = 10\text{ V}, V_{DS} = 0.1\text{ V}$	$R_{DS(on)}$	—	0.09	—	$\Omega$
Operating Gate Voltage (main)	$V_{DS} = 28\text{ V}, I_{DQ} = 520\text{ mA}$	$V_{GS}$	2.5	3.0	3.5	V
Operating Gate Voltage (peak)	$V_{DS} = 28\text{ V}, I_{DQ} = 0\text{ mA}$	$V_{GS}$	0.7	1.1	1.5	V
Gate Leakage Current	$V_{GS} = 10\text{ V}, V_{DS} = 0\text{ V}$	$I_{GSS}$	—	—	1.0	$\mu\text{A}$

## Maximum Ratings

Parameter	Symbol	Value	Unit
Drain-source Voltage	$V_{DSS}$	65	V
Gate-source Voltage	$V_{GS}$	-6 to +10	V
Junction Temperature	$T_J$	200	$^{\circ}\text{C}$
Storage Temperature Range	$T_{STG}$	-40 to +150	$^{\circ}\text{C}$
Thermal Resistance (main, $T_{CASE} = 70^{\circ}\text{C}$ , 80 W CW class AB)	$R_{\theta JC}$	0.86	$^{\circ}\text{C}/\text{W}$
	$R_{\theta JC}$	0.64	$^{\circ}\text{C}/\text{W}$
Thermal Resistance (peak, $T_{CASE} = 70^{\circ}\text{C}$ , 110 W CW class C)	$R_{\theta JC}$	0.64	$^{\circ}\text{C}/\text{W}$

## Ordering Information

Type and Version	Order Code	Package and Description	Shipping
PTAB182002FC V1 R0	PTAB182002FC-V1-R0	H-37248-4, ceramic open-cavity, earless flange	Tape & Reel, 50 pcs
PTAB182002FC V1 R250	PTAB182002FC-V1-R250	H-37248-4, ceramic open-cavity, earless flange	Tape & Reel, 250 pcs

**Typical Performance** (data taken in a production Doherty test fixture)

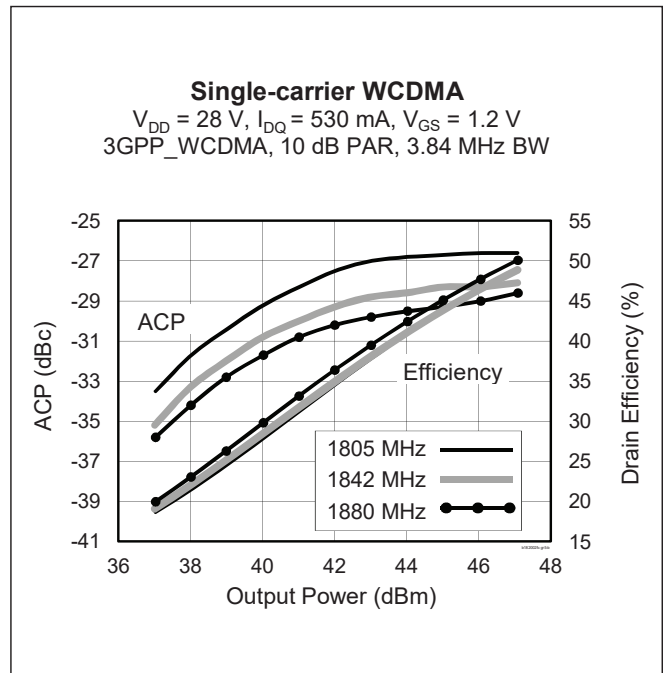
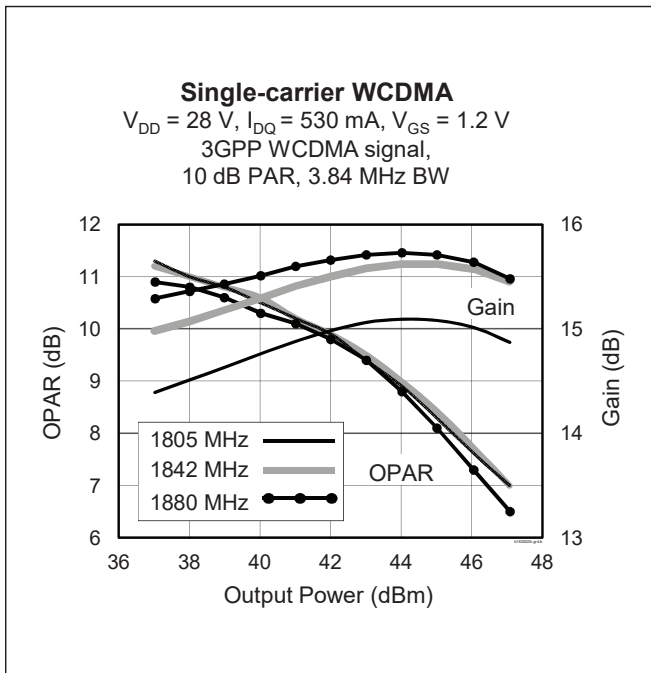
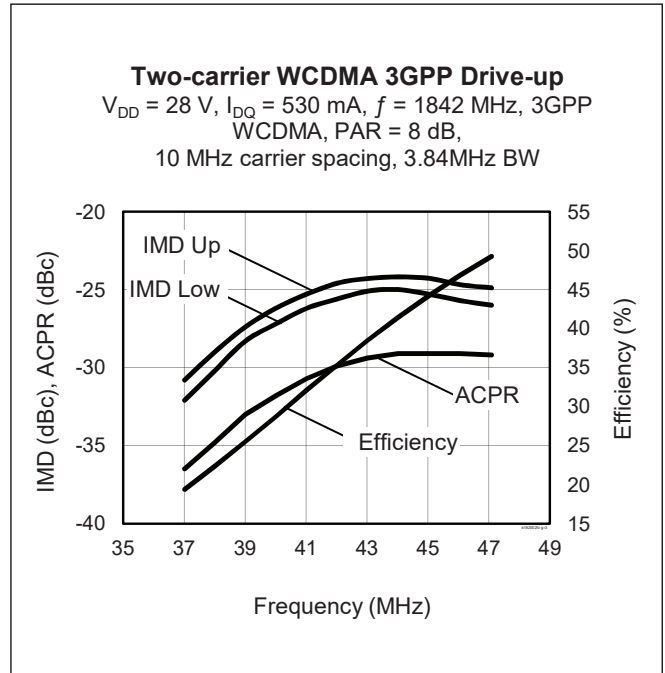
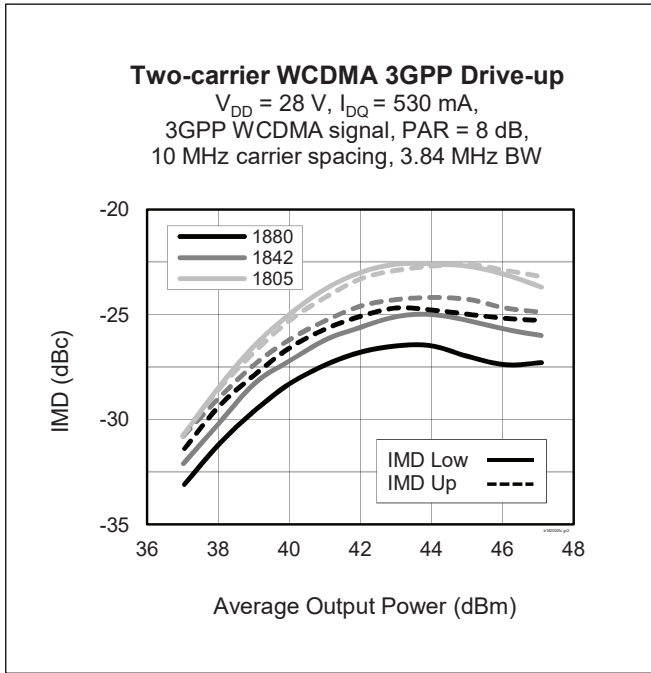

Typical Performance (cont.)

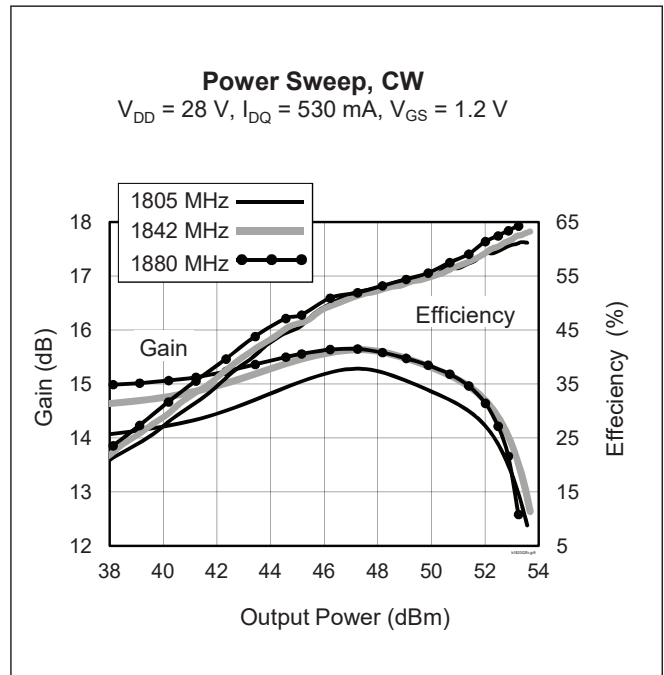
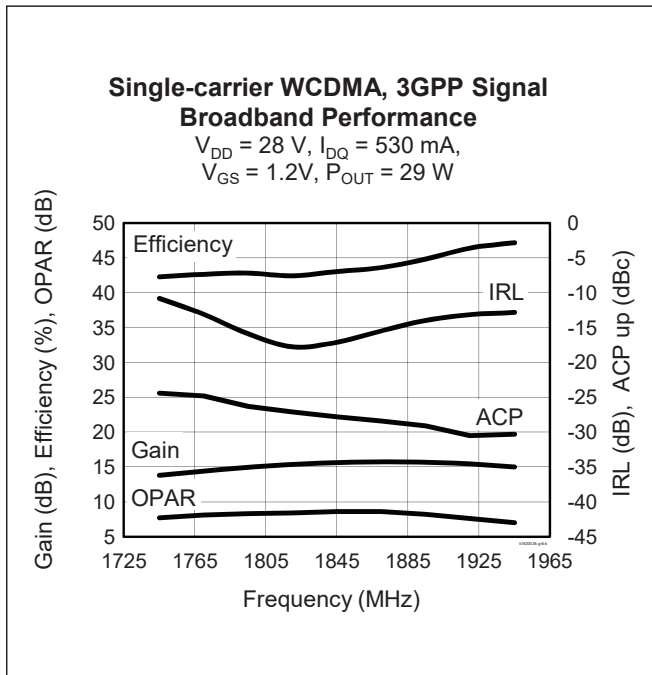

Load Pull Performance

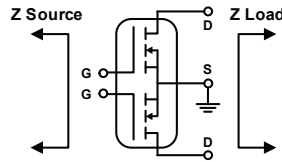

Main Side Load Pull Performance – Pulsed CW signal: 12  $\mu\text{sec}$ , 10% duty cycle; 28 V, 530 mA

Class AB		$P_{1dB}$									
		Max Output Power					Max PAE				
Freq [MHz]	$Z_s \Omega$	$Z_l \Omega$	Gain [dB]	$P_{OUT}$ [dBm]	$P_{OUT}$ [W]	PAE %	$Z_l \Omega$	Gain [dB]	$P_{OUT}$ [dBm]	$P_{OUT}$ [W]	PAE %
1805	5.9 – j9.5	2.8 – j5.4	17.4	50.50	112	56.0	6.1 – j6.3	19.7	48.63	73	67.0
1842	7.5 – j9.7	2.7 – j5.7	17.2	50.26	106	54.4	6.9 – j4.8	20.0	48.08	64	66.2
1880	9.5 – j10.3	3.0 – j5.7	17.8	50.28	107	56.1	6.7 – j5.2	20.1	48.38	69	66.3

Peak Side Load Pull Performance – Pulsed CW signal: 12  $\mu\text{sec}$ , 10% duty cycle; 28 V, 10 mA

Class C		$P_{1dB}$									
		Max Output Power					Max PAE				
Freq [MHz]	$Z_s \Omega$	$Z_l \Omega$	Gain [dB]	$P_{OUT}$ [dBm]	$P_{OUT}$ [W]	PAE %	$Z_l \Omega$	Gain [dB]	$P_{OUT}$ [dBm]	$P_{OUT}$ [W]	PAE %
1805	11.0 – j6.1	1.3 – j5.5	15.7	52.43	175	54.4	2.8 – j4.5	17.7	50.60	115	70.2
1842	8.0 – j4.8	1.3 – j5.8	16.2	52.38	173	54.7	2.7 – j4.7	17.8	50.50	112	69.0
1880	6.7 – j2.4	1.4 – j6.0	16.8	52.33	171	54.9	2.7 – j4.8	18.0	50.40	110	68.5

### Reference Circuit

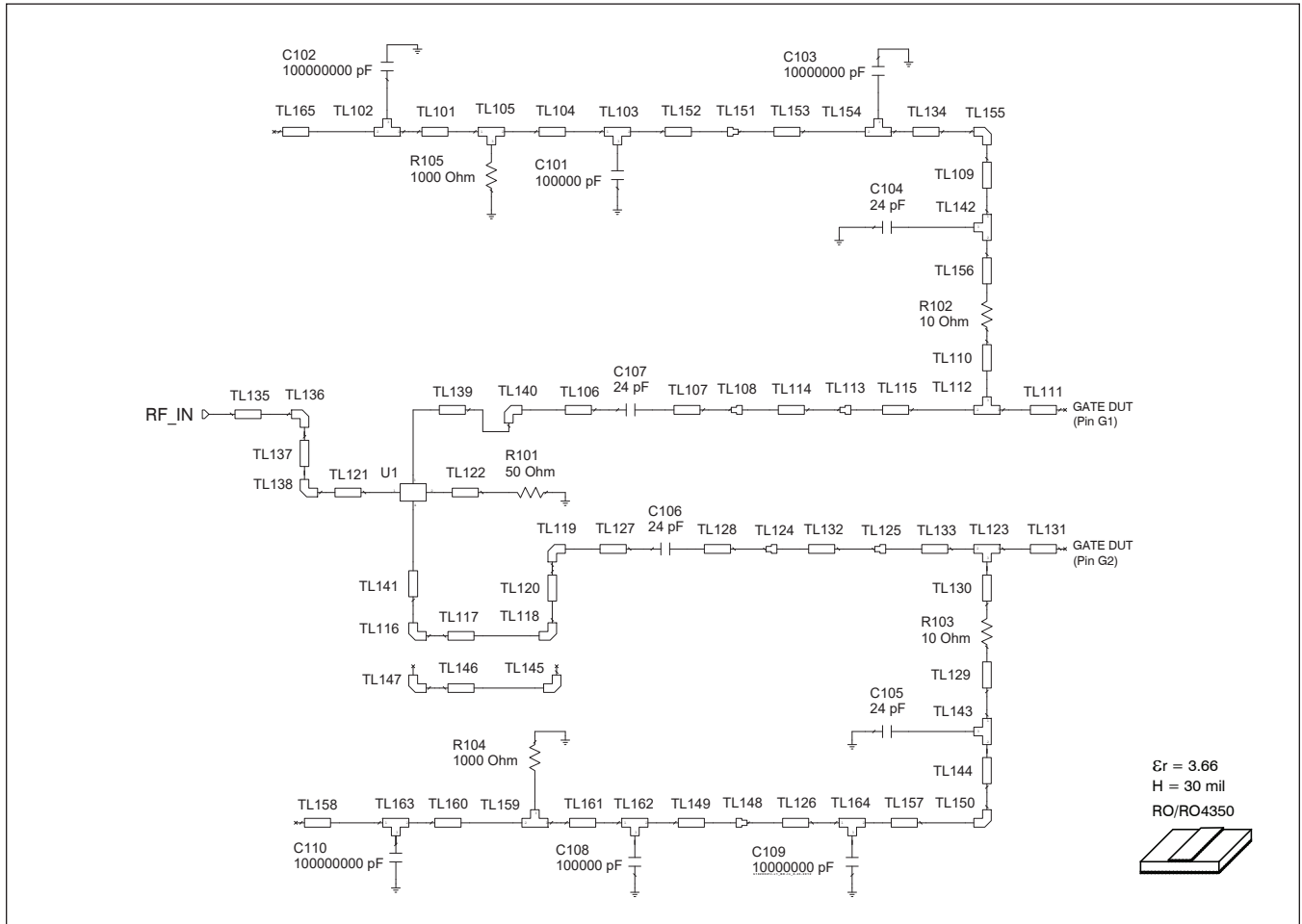

Reference circuit input schematic for  $f = 1880 \text{ MHz}$

Reference Circuit (cont.)

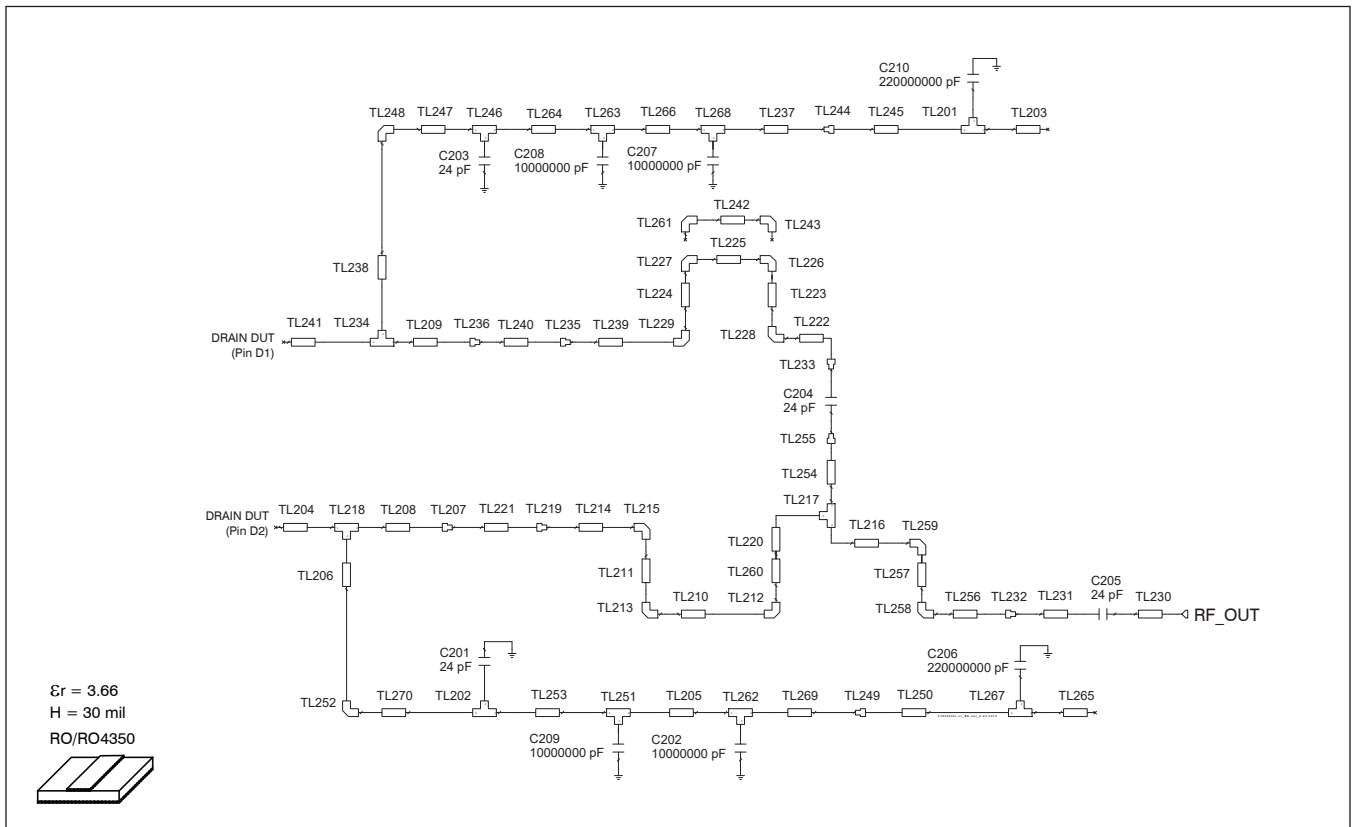

Reference circuit output schematic for  $f = 1880 \text{ MHz}$

Reference Circuit

DUT	PTAB182002FC
Test Fixture Part No.	LTA/PTAB182002FC
PCB	Rogers 4350, 0.762 mm [.030"] thick, 2 oz. copper, $\epsilon_r = 3.66$
Find Gerber files for this test fixture on the Wolfspeed Web site at <a href="http://www.wolfspeed.com/RF">www.wolfspeed.com/RF</a>	

## Reference Circuit (cont.)

## Reference Circuit Assembly

## Electrical Characteristics at 1880 MHz

Transmission Line	Electrical Characteristics	Dimensions: mm	Dimensions: mils
<b>Input</b>			
TL101	0.029 $\lambda$ , 28.26 $\Omega$	W = 3.81, L = 2.67	W = 150, L = 105
TL102, TL103, TL105, TL159, TL162, TL163	0.014 $\lambda$ , 28.26 $\Omega$	W1 = 3.81, W2 = 3.81, W3 = 1.27	W1 = 150, W2 = 150, W3 = 50
TL104	0.020 $\lambda$ , 28.26 $\Omega$	W = 3.81, L = 1.83	W = 150, L = 72
TL106	0.032 $\lambda$ , 51.05 $\Omega$	W = 1.63, L = 3.05	W = 64, L = 120
TL107	0.091 $\lambda$ , 51.05 $\Omega$	W = 1.63, L = 8.64	W = 64, L = 340
TL109	0.022 $\lambda$ , 76.77 $\Omega$	W = 0.76, L = 2.16	W = 30, L = 85
TL110, TL130	0.026 $\lambda$ , 76.77 $\Omega$	W = 0.76, L = 2.54	W = 30, L = 100
TL111	0.012 $\lambda$ , 12.71 $\Omega$	W = 10.03, L = 1.02	W = 395, L = 40
TL112	0.009 $\lambda$ , 12.71 $\Omega$	W1 = 10.03, W2 = 10.03, W3 = 0.76	W1 = 395, W2 = 395, W3 = 30
TL114	0.014 $\lambda$ , 23.02 $\Omega$	W = 4.95, L = 1.27	W = 195, L = 50
TL115	0.098 $\lambda$ , 12.71 $\Omega$	W = 10.03, L = 8.59	W = 395, L = 338
TL117, TL146	0.013 $\lambda$ , 51.05 $\Omega$	W = 1.63, L = 1.27	W = 64, L = 50
TL120	0.066 $\lambda$ , 51.05 $\Omega$	W = 1.63, L = 6.27	W = 64, L = 247
TL121	0.038 $\lambda$ , 51.05 $\Omega$	W = 1.63, L = 3.56	W = 64, L = 140
TL122	0.060 $\lambda$ , 51.05 $\Omega$	W = 1.63, L = 5.69	W = 64, L = 224
TL123	0.009 $\lambda$ , 11.33 $\Omega$	W1 = 11.43, W2 = 11.43, W3 = 0.76	W1 = 450, W2 = 450, W3 = 30
TL126	0.144 $\lambda$ , 76.77 $\Omega$	W = 0.76, L = 14	W = 30, L = 551
TL127	0.037 $\lambda$ , 51.05 $\Omega$	W = 1.63, L = 3.45	W = 64, L = 136
TL128	0.013 $\lambda$ , 51.05 $\Omega$	W = 1.63, L = 1.19	W = 64, L = 47
TL129	0.055 $\lambda$ , 76.77 $\Omega$	W = 0.76, L = 5.38	W = 30, L = 212
TL131	0.012 $\lambda$ , 11.33 $\Omega$	W = 11.43, L = 1.02	W = 450, L = 40
TL132	0.055 $\lambda$ , 38.04 $\Omega$	W = 2.54, L = 5.08	W = 100, L = 200
TL133	0.102 $\lambda$ , 11.33 $\Omega$	W = 11.43, L = 8.89	W = 450, L = 350
TL134	0.031 $\lambda$ , 76.77 $\Omega$	W = 0.76, L = 2.97	W = 30, L = 117
TL135	0.040 $\lambda$ , 51.05 $\Omega$	W = 1.63, L = 3.81	W = 64, L = 149
TL137	0.023 $\lambda$ , 51.05 $\Omega$	W = 1.63, L = 2.16	W = 64, L = 85
TL139	0.043 $\lambda$ , 51.05 $\Omega$	W = 1.63, L = 4.06	W = 64, L = 160
TL141	0.118 $\lambda$ , 51.05 $\Omega$	W = 1.63, L = 11.18	W = 64, L = 440
TL142, TL143, TL 154, TL164	0.013 $\lambda$ , 76.77 $\Omega$	W1 = 0.76, W2 = 0.76, W3 = 1.27	W1 = 30, W2 = 30, W3 = 50
TL144	0.010 $\lambda$ , 76.77 $\Omega$	W = 0.76, L = 0.97	W = 30, L = 38

table continued on next page



**Reference Circuit** (cont.)

**Electrical Characteristics at 1880 MHz**

Transmission Line	Electrical Characteristics	Dimensions: mm	Dimensions: mils
<b>Input (cont.)</b>			
TL149	0.078 $\lambda$ , 28.26 $\Omega$	W = 3.81, L = 7.09	W = 150, L = 279
TL152	0.009 $\lambda$ , 28.26 $\Omega$	W = 3.81, L = 0.81	W = 150, L = 32
TL153	0.192 $\lambda$ , 76.77 $\Omega$	W = 0.76, L = 18.62	W = 30, L = 733
TL156	0.054 $\lambda$ , 76.77 $\Omega$	W = 0.76, L = 5.23	W = 30, L = 206
TL157	0.024 $\lambda$ , 76.77 $\Omega$	W = 0.76, L = 2.31	W = 30, L = 91
TL158, TL165	0.042 $\lambda$ , 28.26 $\Omega$	W = 3.81, L = 3.81	W = 150, L = 150
TL160	0.013 $\lambda$ , 28.26 $\Omega$	W = 3.81, L = 1.19	W = 150, L = 47
TL161	0.025 $\lambda$ , 28.26 $\Omega$	W = 3.81, L = 2.31	W = 150, L = 91

**Output**

TL201, TL267	0.014 $\lambda$ , 28.26 $\Omega$	W1 = 3.81, W2 = 3.81, W3 = 1.27	W1 = 150, W2 = 150, W3 = 50
TL202, TL251, TL262	0.014 $\lambda$ , 42.19 $\Omega$	W1 = 2.18, W2 = 2.18, W3 = 1.27	W1 = 86, W2 = 86, W3 = 50
TL203, TL265	0.099 $\lambda$ , 28.26 $\Omega$	W = 3.81, L = 9.04	W = 150, L = 356
TL204	0.002 $\lambda$ , 11.04 $\Omega$	W = 11.76, L = 0.13	W = 463, L = 5
TL205	0.015 $\lambda$ , 42.19 $\Omega$	W = 2.18, L = 1.42	W = 86, L = 56
TL206	0.109 $\lambda$ , 42.19 $\Omega$	W = 2.18, L = 10.16	W = 86, L = 400
TL208	0.123 $\lambda$ , 11.04 $\Omega$	W = 11.76, L = 10.72	W = 463, L = 422
TL209	0.120 $\lambda$ , 8.6 $\Omega$	W = 15.52, L = 10.39	W = 611, L = 409
TL210	0.017 $\lambda$ , 25.19 $\Omega$	W = 4.42, L = 1.52	W = 174, L = 60
TL211, L260	0.057 $\lambda$ , 25.19 $\Omega$	W = 4.42, L = 5.13	W = 174, L = 202
TL214	0.005 $\lambda$ , 25.19 $\Omega$	W = 4.42, L = 0.43	W = 174, L = 17
TL216	0.083 $\lambda$ , 31.13 $\Omega$	W = 3.35, L = 7.62	W = 132, L = 300
TL217	0.048 $\lambda$ , 31.13 $\Omega$	W1 = 3.35, W2 = 3.35, W3 = 4.42	W1 = 132, W2 = 132, W3 = 174
TL218	0.025 $\lambda$ , 11.04 $\Omega$	W1 = 11.76, W2 = 11.76, W3 = 2.18	W1 = 463, W2 = 463, W3 = 86
TL220	0.184 $\lambda$ , 25.19 $\Omega$	W = 4.42, L = 16.71	W = 174, L = 658
TL221	0.084 $\lambda$ , 32.41 $\Omega$	W = 3.18, L = 7.77	W = 125, L = 306
TL222, TL239	0.027 $\lambda$ , 47.41 $\Omega$	W = 1.83, L = 2.54	W = 72, L = 100
TL223, TL224	0.034 $\lambda$ , 47.41 $\Omega$	W = 1.83, L = 3.18	W = 72, L = 125
TL225, TL242	0.014 $\lambda$ , 47.41 $\Omega$	W = 1.83, L = 1.27	W = 72, L = 50
TL230	0.032 $\lambda$ , 51.05 $\Omega$	W = 1.63, L = 3.05	W = 64, L = 120
TL231	0.016 $\lambda$ , 51.05 $\Omega$	W = 1.63, L = 1.5	W = 64, L = 59

*table continued on next page*



**Reference Circuit** (cont.)

<b>Electrical Characteristics at 1880 MHz</b>			
<b>Transmission Line</b>	<b>Electrical Characteristics</b>	<b>Dimensions: mm</b>	<b>Dimensions: mils</b>
<b>Output (cont.)</b>			
TL234	0.011 $\lambda$ , 8.6 $\Omega$	W1 = 15.52, W2 = 15.52, W3 = 0.91	W1 = 611, W2 = 611, W3 = 36
TL237	0.051 $\lambda$ , 70.38 $\Omega$	W = 0.91, L = 4.93	W = 36, L = 194
TL238	0.079 $\lambda$ , 70.38 $\Omega$	W = 0.91, L = 7.62	W = 36, L = 300
TL240	0.049 $\lambda$ , 89.14 $\Omega$	W = 0.53, L = 4.78	W = 21, L = 188
TL241	0.002 $\lambda$ , 8.6 $\Omega$	W = 15.52, L = 0.13	W = 611, L = 5
TL245	0.156 $\lambda$ , 28.26 $\Omega$	W = 3.81, L = 14.27	W = 150, L = 562
TL246, TL263, TL268	0.013 $\lambda$ , 70.38 $\Omega$	W1 = 0.91, W2 = 0.91, W3 = 1.27	W1 = 36, W2 = 36, W3 = 50
TL247	0.127 $\lambda$ , 70.38 $\Omega$	W = 0.91, L = 12.24	W = 36, L = 482
TL250	0.198 $\lambda$ , 28.26 $\Omega$	W = 3.81, L = 18.11	W = 150, L = 713
TL253	0.038 $\lambda$ , 42.19 $\Omega$	W = 2.18, L = 3.58	W = 86, L = 141
TL254	0.0003 $\lambda$ , 31.13 $\Omega$	W = 3.35, L = 0.03	W = 132, L = 1
TL256	0.028 $\lambda$ , 31.13 $\Omega$	W = 3.35, L = 2.54	W = 132, L = 100
TL257	0.062 $\lambda$ , 31.13 $\Omega$	W = 3.35, L = 5.69	W = 132, L = 224
TL264	0.021 $\lambda$ , 70.38 $\Omega$	W = 0.91, L = 2.03	W = 36, L = 80
TL266	0.015 $\lambda$ , 70.38 $\Omega$	W = 0.91, L = 1.42	W = 36, L = 56
TL269	0.086 $\lambda$ , 42.19 $\Omega$	W = 2.18, L = 8	W = 86, L = 315
TL270	0.027 $\lambda$ , 42.19 $\Omega$	W = 2.18, L = 2.51	W = 86, L = 99

**Reference Circuit** (cont.)

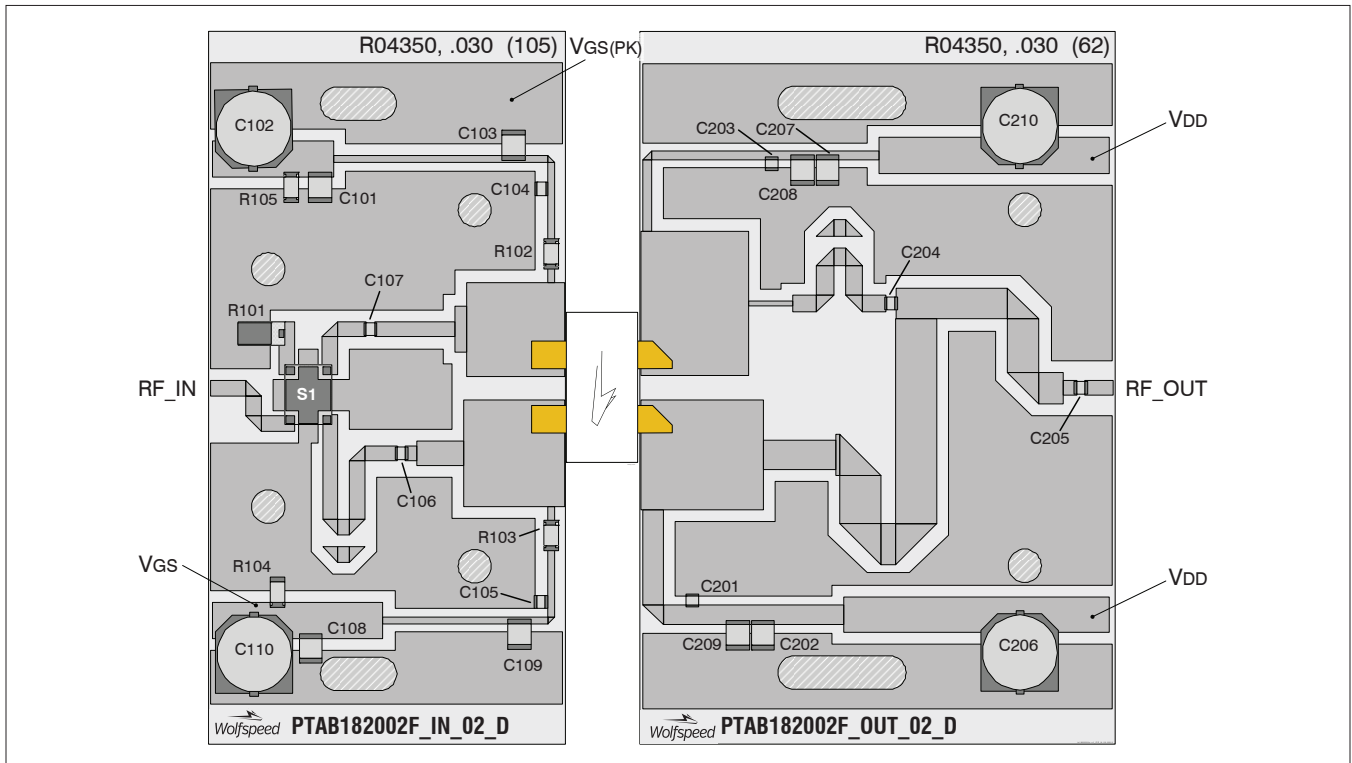

Reference circuit assembly diagram (not to scale)

**Components Information**

Component	Description	Suggested Supplier	P/N
<b>Input</b>			
C101, C108	Chip capacitor, 0.1 $\mu$ F	Kemet	C120C104K5RACTU
C102, C110	Capacitor, 100 $\mu$ F	Panasonic	EEE-FP1V101AP
C103, C109	Capacitor, 10 $\mu$ F	Taiyo Yuden	UMK325C7106MM-T
C104, C105, C106, C107	Chip capacitor, 24 pF	ATC	ATC100A240JW150XB
R101	Resistor, 50 $\Omega$	Anaren	C16A5024
R102, R103	Resistor, 10 $\Omega$	Panasonic	ERJ-8GEYJ100V
R104, R105	Resistor, 1000 $\Omega$	Panasonic	ERJ-8GEYJ102V
U1 / S1	90° RF directional coupler	Anaren	X3C19P1-05S
<b>Output</b>			
C201, C203, C204, C205	Chip capacitor, 24 pF	ATC	ATC100A240JW150XB
C202, C207, C208, C209	Capacitor, 10 $\mu$ F	Taiyo Yuden	UMK325C7106MM-T
C206, C210	Capacitor, 220 $\mu$ F	Panasonic	EEEF1V221AP

**Pinout Diagram** (top view)

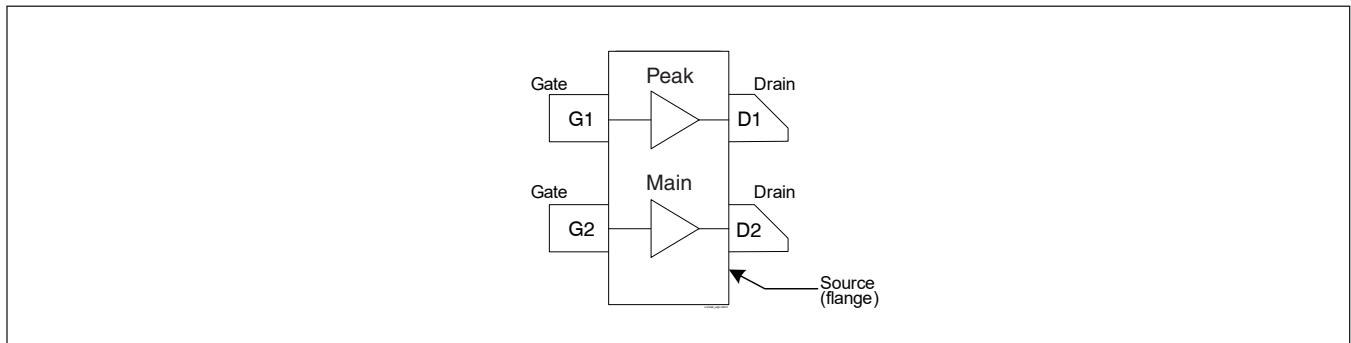

*Lead connections for PTAB182002FC*

**See next page for Package Outline Specifications**

Package Outline Specifications

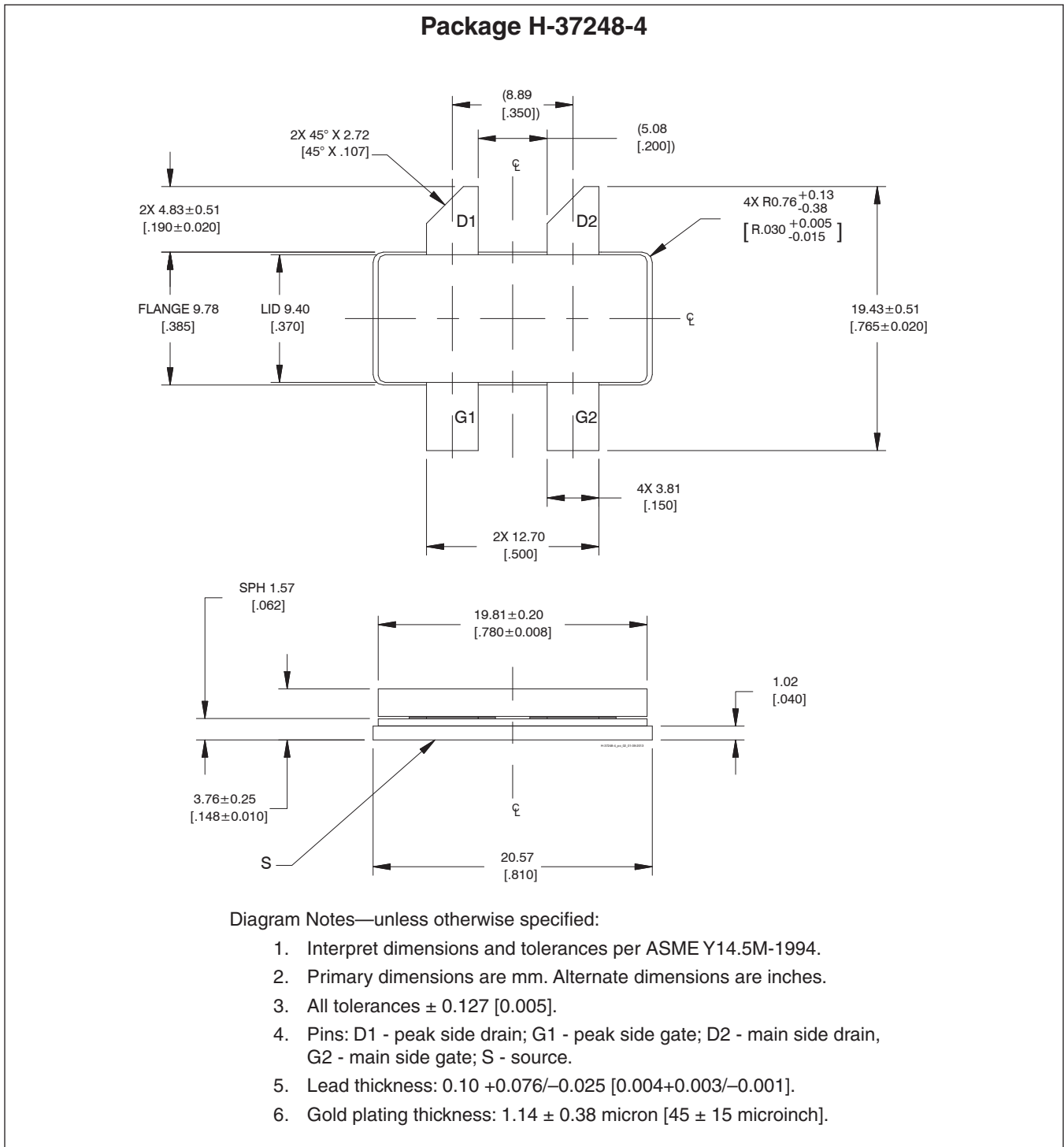

## Revision History

Revision	Date	Data Sheet Type	Page	Subjects (major changes since last revision)
04.1	2016-06-09	Data Sheet	2	Updated ordering code to R0
05	2018-06-22	Production	All	Converted to Wolfspeed Data Sheet

For more information, please contact:

4600 Silicon Drive  
 Durham, North Carolina, USA 27703  
[www.wolfspeed.com/RF](http://www.wolfspeed.com/RF)

Sales Contact  
[RFSales@wolfspeed.com](mailto:RFSales@wolfspeed.com)

RF Product Marketing Contact  
[RFMarketing@wolfspeed.com](mailto:RFMarketing@wolfspeed.com)  
 919.407.7816

## Notes

---

### Disclaimer

Specifications are subject to change without notice. Cree, Inc. believes the information contained within this data sheet to be accurate and reliable. However, no responsibility is assumed by Cree for any infringement of patents or other rights of third parties which may result from its use. No license is granted by implication or otherwise under any patent or patent rights of Cree. Cree makes no warranty, representation or guarantee regarding the suitability of its products for any particular purpose. "Typical" parameters are the average values expected by Cree in large quantities and are provided for information purposes only. These values can and do vary in different applications and actual performance can vary over time. All operating parameters should be validated by customer's technical experts for each application. Cree products are not designed, intended or authorized for use as components in applications intended for surgical implant into the body or to support or sustain life, in applications in which the failure of the Cree product could result in personal injury or death or in applications for planning, construction, maintenance or direct operation of a nuclear facility.

## Данный компонент на территории Российской Федерации

### Вы можете приобрести в компании MosChip.

Для оперативного оформления запроса Вам необходимо перейти по данной ссылке:

<http://moschip.ru/get-element>

Вы можете разместить у нас заказ для любого Вашего проекта, будь то серийное производство или разработка единичного прибора.

В нашем ассортименте представлены ведущие мировые производители активных и пассивных электронных компонентов.

Нашей специализацией является поставка электронной компонентной базы двойного назначения, продукции таких производителей как XILINX, Intel (ex.ALTERA), Vicor, Microchip, Texas Instruments, Analog Devices, Mini-Circuits, Amphenol, Glenair.

Сотрудничество с глобальными дистрибьюторами электронных компонентов, предоставляет возможность заказывать и получать с международных складов практически любой перечень компонентов в оптимальные для Вас сроки.

На всех этапах разработки и производства наши партнеры могут получить квалифицированную поддержку опытных инженеров.

Система менеджмента качества компании отвечает требованиям в соответствии с ГОСТ Р ИСО 9001, ГОСТ РВ 0015-002 и ЭС РД 009

### Офис по работе с юридическими лицами:

105318, г.Москва, ул.Щербаковская д.3, офис 1107, 1118, ДЦ «Щербаковский»

Телефон: +7 495 668-12-70 (многоканальный)

Факс: +7 495 668-12-70 (доб.304)

E-mail: [info@moschip.ru](mailto:info@moschip.ru)

Skype отдела продаж:

moschip.ru

moschip.ru\_4

moschip.ru\_6

moschip.ru\_9