

THIS DRAWING IS UNPUBLISHED. RELEASED FOR PUBLICATION
 © COPYRIGHT - BY - ALL RIGHTS RESERVED.

REVISIONS					
P	LTR	DESCRIPTION	DATE	DWN	APVD
T		REDRAWN/REVISED PER ECO-17-001756	10NOV2017	GR	JO

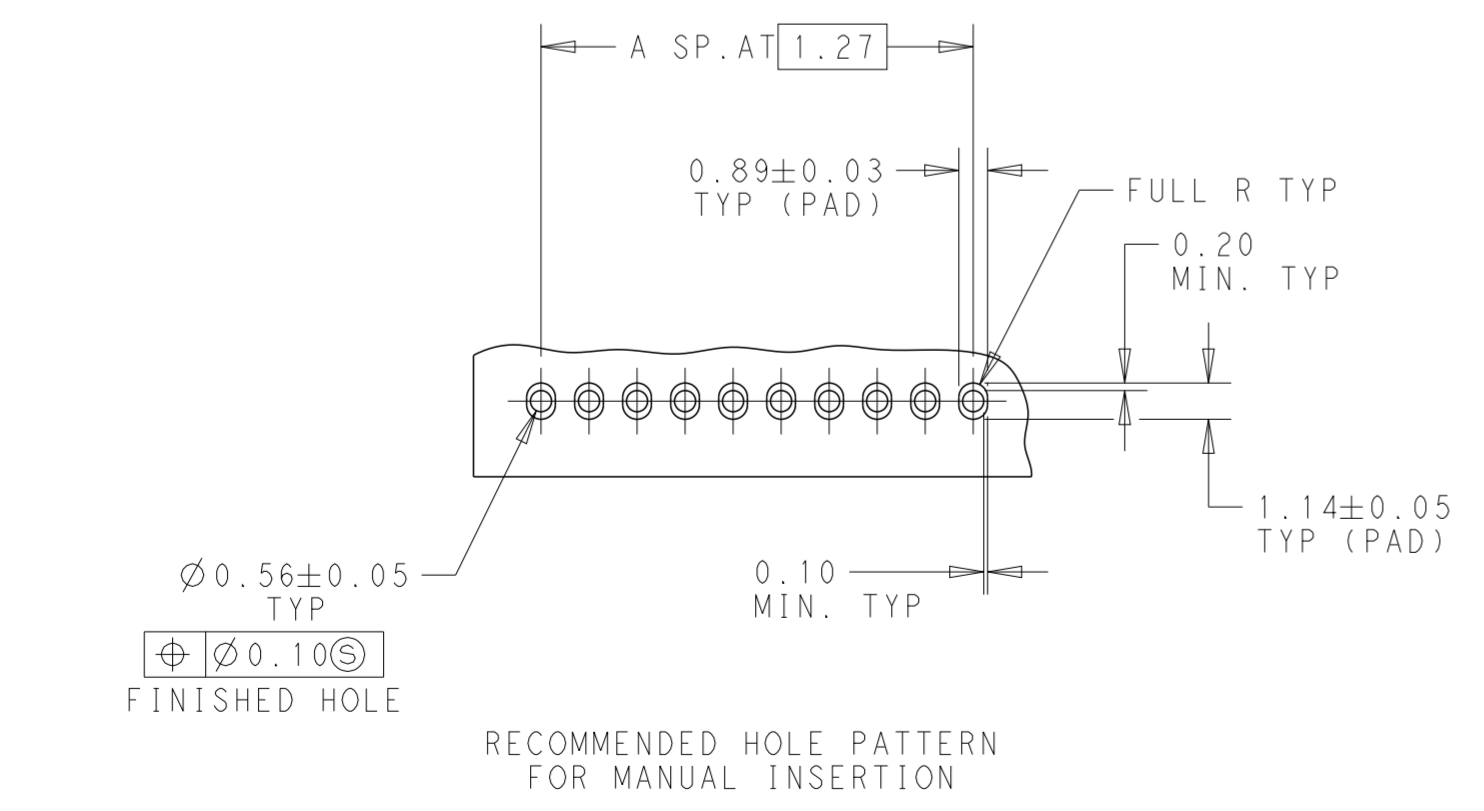

- 1 CONTACT AREAS PLATED WITH 0.76µm GOLD; SOLDER TAILS PLATED WITH 3.81µm MIN TIN-LEAD; ALL OVER 1.27µm MIN NICKEL
- 2. NOTE DELETED
- 3 THE NOTED DIMENSIONS APPLY AT THE INTERSECTION OF THE POST AND HOUSING.
- 4 CONTACT AREAS PLATED WITH 0.76µm GOLD; SOLDER TAILS PLATED WITH 3.81µm MIN TIN; ALL OVER 1.27µm MIN NICKEL
- 5. NOTE DELETED
- 6 FINISH: 0.03µm MIN GOLD ON GOLD PLATED AREA, 3.81µm MATTE IN TIN-LEAD ON TIN PLATED AREA. UNDER PLATING: 1.27µm NICKEL ON ENTIRE CONTACT. GOLD AND TIN PLATING MAY NOT OVERLAP.
- 7 FINISH: 0.03µm MIN GOLD ON GOLD PLATED AREA, 3.81µm MATTE IN TIN ON TIN PLATED AREA. UNDER PLATING: 1.27µm NICKEL ON ENTIRE CONTACT. GOLD AND TIN PLATING MAY NOT OVERLAP.
- 8. NOTE DELETED
- 9. NOTE DELETED
- 10. NOTE DELETED
- 11 MATERIAL: HOUSING:LCP, COLOR-BLACK CONTACT:COPPER ALLOY

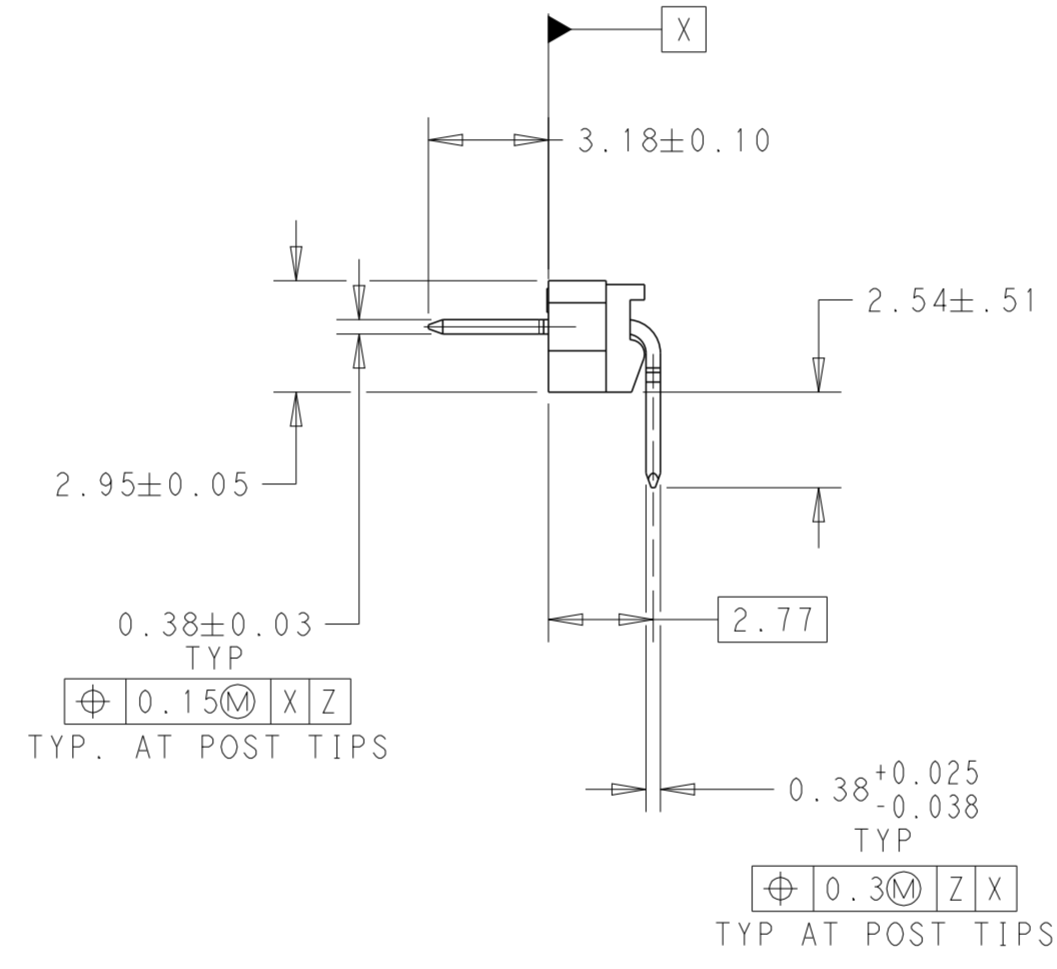
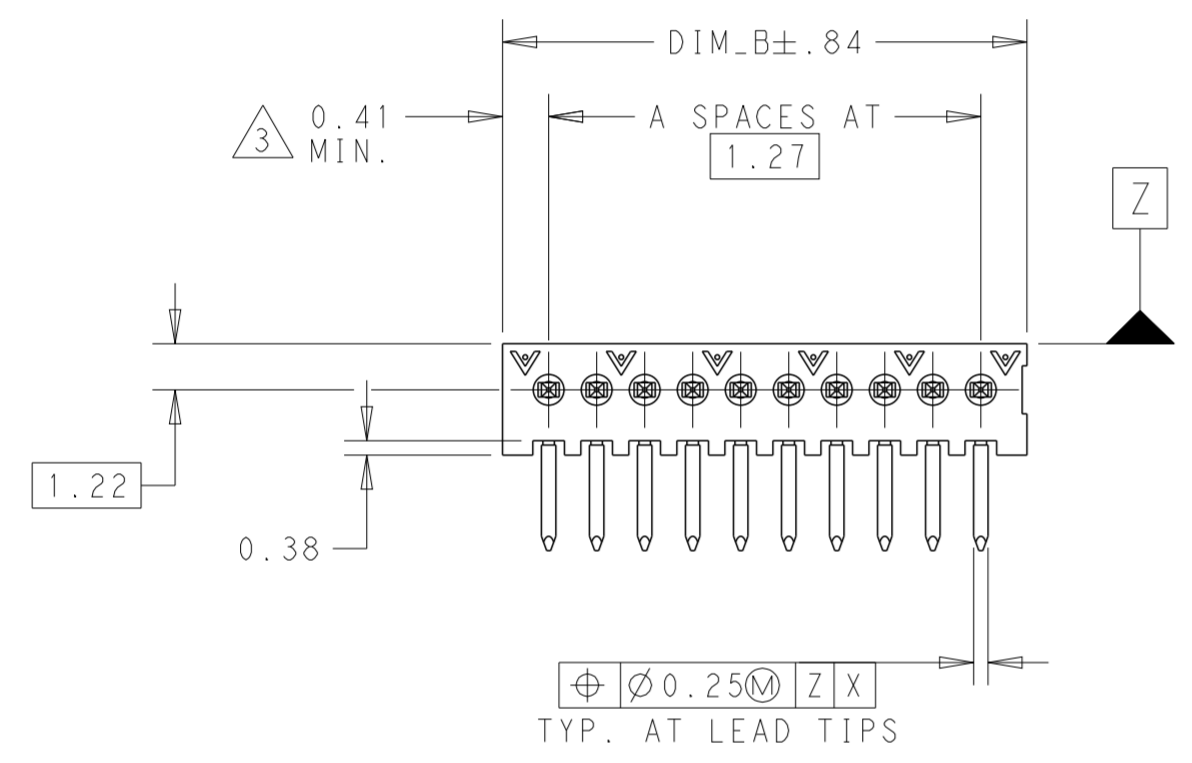
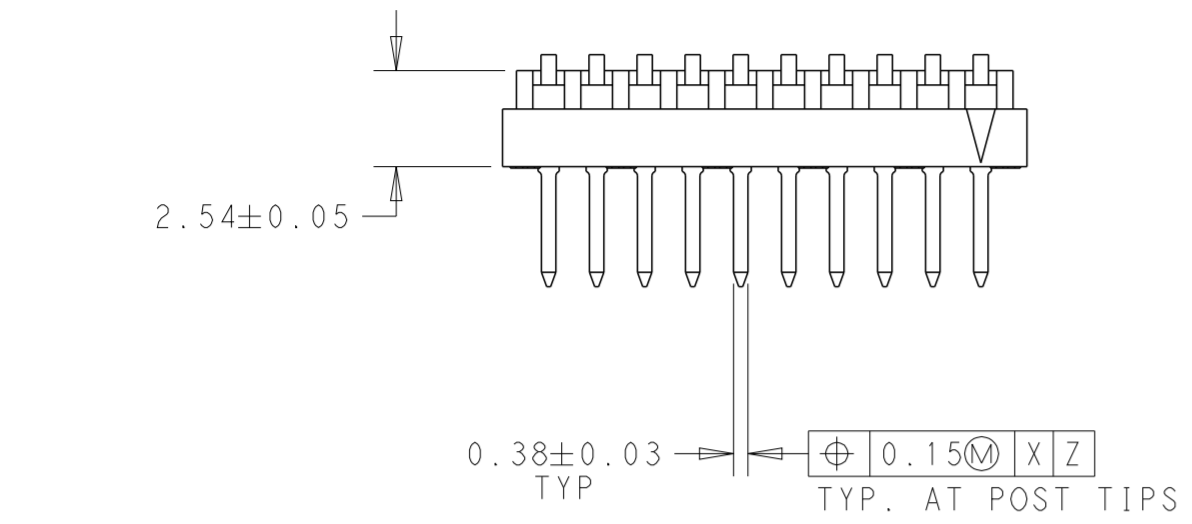
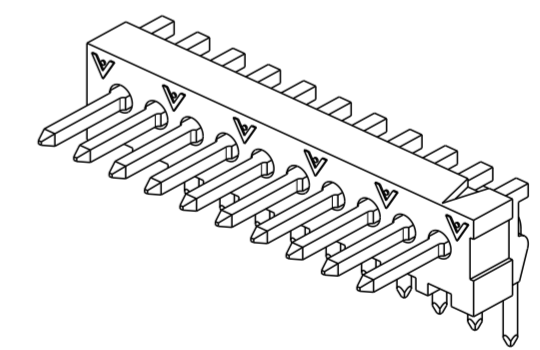

THIS DRAWING IS A CONTROLLED DOCUMENT.		DWN G. RAMESH 10NOV2017	TE Connectivity	
DIMENSIONS: mm		CHK J. OLSON 10NOV2017		
TOLERANCES UNLESS OTHERWISE SPECIFIED:		APVD J. OLSON 10NOV2017	NAME HEADER ASSEMBLY, RIGHT ANGLE, UNSHROUDED, SINGLE ROW, AMPMODU System 50	
0 PLC ±		PRODUCT SPEC 108-1093	SIZE A200779	
1 PLC ±		APPLICATION SPEC 114-25031	CAGE CODE C-104186	
2 PLC ±0.3		WEIGHT -	DRAWING NO -	
3 PLC ±0.13		CUSTOMER DRAWING	RESTRICTED TO	
4 PLC ±		SCALE 5:1	SHEET 1 OF 2	
ANGLES ±0.5°			REV T	
FINISH SEE TABLE				

THIS DRAWING IS UNPUBLISHED. RELEASED FOR PUBLICATION
 © COPYRIGHT - BY - ALL RIGHTS RESERVED.

REVISIONS				
P	LTR	DESCRIPTION	DATE	APVD
-		SEE SHEET 1	-	-

7	39.75	30	31	9-104168-0
	63.88	49	50	8-104168-9
	57.53	44	45	8-104168-8
	51.18	39	40	8-104168-7
	44.83	34	35	8-104168-6
	38.48	29	30	8-104168-5
	34.67	26	27	8-104168-4
	32.13	24	25	8-104168-3
	28.32	21	22	8-104168-2
	25.78	19	20	8-104168-1
	21.97	16	17	8-104168-0
	19.43	14	15	7-104168-9
	16.89	12	13	7-104168-8
	15.62	11	12	7-104168-7
	13.08	9	10	7-104168-6
	10.54	7	8	7-104168-5
	9.27	6	7	7-104168-4
	8.00	5	6	7-104168-3
	6.73	4	5	7-104168-2
	5.46	3	4	7-104168-1
4	39.75	30	31	7-104168-0
	63.88	49	50	6-104168-9
	57.53	44	45	6-104168-8
	51.18	39	40	6-104168-7
	44.83	34	35	6-104168-6
	38.48	29	30	6-104168-5
	34.67	26	27	6-104168-4
	32.13	24	25	6-104168-3
	28.32	21	22	6-104168-2
	25.78	19	20	6-104168-1
	21.97	16	17	6-104168-0
	19.43	14	15	5-104168-9
	16.89	12	13	5-104168-8
	15.62	11	12	5-104168-7
	13.08	9	10	5-104168-6
	10.54	7	8	5-104168-5
	9.27	6	7	5-104168-4
	8.00	5	6	5-104168-3
	6.73	4	5	5-104168-2
	5.46	3	4	5-104168-1
FINISH	DIM_ B	A SPACES	NO OF POSN	PART NUMBER

6	39.75	30	31	4-104186-0
	63.88	49	50	3-104186-9
	57.53	44	45	3-104186-8
	51.18	39	40	3-104186-7
	44.83	34	35	3-104186-6
	38.48	29	30	3-104186-5
	34.67	26	27	3-104186-4
	32.13	24	25	3-104186-3
	28.32	21	22	3-104186-2
	25.78	19	20	3-104186-1
	21.97	16	17	3-104186-0
	19.43	14	15	2-104186-9
	16.89	12	13	2-104186-8
	15.62	11	12	2-104186-7
	13.08	9	10	2-104186-6
	10.54	7	8	2-104186-5
	9.27	6	7	2-104186-4
	8.00	5	6	2-104186-3
	6.73	4	5	2-104186-2
	5.46	3	4	2-104186-1
1	39.75	30	31	2-104186-0
	63.88	49	50	1-104186-9
	57.53	44	45	1-104186-8
	51.18	39	40	1-104186-7
	44.83	34	35	1-104186-6
	38.48	29	30	1-104186-5
	34.67	26	27	1-104186-4
	32.13	24	25	1-104186-3
	28.32	21	22	1-104186-2
	25.78	19	20	1-104186-1
	21.97	16	17	1-104186-0
	19.43	14	15	104186-9
	16.89	12	13	104186-8
	15.62	11	12	104186-7
	13.08	9	10	104186-6
	10.54	7	8	104186-5
	9.27	6	7	104186-4
	8.00	5	6	104186-3
	6.73	4	5	104186-2
	5.46	3	4	104186-1
FINISH	DIM_ B	A SPACES	NO OF POSN	PART NUMBER

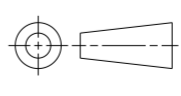
THIS DRAWING IS A CONTROLLED DOCUMENT.		DWN G. RAMESH 10NOV2017	 TE Connectivity
DIMENSIONS: mm		CHK J. OLSON 10NOV2017	
 TOLERANCES UNLESS OTHERWISE SPECIFIED: 0 PLC ± 1 PLC ± 2 PLC ±0.3 3 PLC ±0.13 4 PLC ± ANGLES ±0.5° FINISH		APVD J. OLSON 10NOV2017	
		NAME HEADER ASSEMBLY, RIGHT ANGLE, UNSHROUDED, SINGLE ROW, AMPMODU System 50	
MATERIAL	PRODUCT SPEC 108-1093	APPLICATION SPEC 114-25031	SIZE A2
	WEIGHT -	DRAWING NO C-104186	RESTRICTED TO
CUSTOMER DRAWING		SCALE 5:1	SHEET 2 OF 2
		REV T	

Данный компонент на территории Российской Федерации

Вы можете приобрести в компании MosChip.

Для оперативного оформления запроса Вам необходимо перейти по данной ссылке:

<http://moschip.ru/get-element>

Вы можете разместить у нас заказ для любого Вашего проекта, будь то серийное производство или разработка единичного прибора.

В нашем ассортименте представлены ведущие мировые производители активных и пассивных электронных компонентов.

Нашей специализацией является поставка электронной компонентной базы двойного назначения, продукции таких производителей как XILINX, Intel (ex.ALTERA), Vicor, Microchip, Texas Instruments, Analog Devices, Mini-Circuits, Amphenol, Glenair.

Сотрудничество с глобальными дистрибьюторами электронных компонентов, предоставляет возможность заказывать и получать с международных складов практически любой перечень компонентов в оптимальные для Вас сроки.

На всех этапах разработки и производства наши партнеры могут получить квалифицированную поддержку опытных инженеров.

Система менеджмента качества компании отвечает требованиям в соответствии с ГОСТ Р ИСО 9001, ГОСТ РВ 0015-002 и ЭС РД 009

Офис по работе с юридическими лицами:

105318, г.Москва, ул.Щербаковская д.3, офис 1107, 1118, ДЦ «Щербаковский»

Телефон: +7 495 668-12-70 (многоканальный)

Факс: +7 495 668-12-70 (доб.304)

E-mail: info@moschip.ru

Skype отдела продаж:

moschip.ru

moschip.ru_4

moschip.ru_6

moschip.ru_9