

Driver IC for PPC

High Performance, High Reliability 36V 2ch DC Brush Motor Drivers for PPC's etc.

BD62220AEFV

General Description

BD62220AEFV is a built-in 2 channel H-bridge motor driver for 2 DC brush motors or 1 stepper motor. This driver can facilitate low power consumption by direct PWM or PWM constant current control. There are built in protection circuits in this IC. It is possible to output an abnormal detection signal for Wired-OR that notifies each protection circuit operation, which contributes to set high reliability.

Features

- Single Power Supply Input (rated voltage of 36V)
- Rated Output Current (peak): 2.0A(2.8A)
- Low ON-Resistance DMOS Output
- Forward, Reverse, Brake, Open
- Power Save Function
- External PWM Control
- PWM Constant Current Control (current limit function)
- Built-in Spike Noise Cancel Function (external noise filter is unnecessary)
- Driver for 2 DC Brush Motor
- Driver for 1 Stepper motor
- FULL STEP, HALF STEP (driving stepper motor)
- μ STEP Drive by External DAC (driving stepper motor)
- Built-in logic input pull-down resistor
- Cross-conduction Prevention Circuit
- Output detection signal during abnormal states (Wired-OR)
- Thermal Shutdown Circuit (TSD)
- Over-current Protection Circuit (OCP)
- Under Voltage Lock out Circuit (UVLO)
- Over Voltage Lock out Circuit (OVLO)
- Ghost Supply Prevention (protects against malfunction when power supply is disconnected)
- Adjacent Pins Short Protection
- Inverted Mounting Protection
- Microminiature, ultra-thin and high heat-radiation (exposed metal type) HTSSOP-B28 package

Application

Plain Paper Copier (PPC), Multi-function Printer, Laser Printer, Inkjet Printer, Photo Printer, FAX, Mini Printer and etc.

Key Specifications

- Power Supply Voltage Range: 8 to 28 [V]
- Rated Output Current: 2.0 [A]
- Rated Output Current (Peak): 2.8 [A]
- Operating Temperature Range: -25 to +85 [°C]
- Output ON-Resistance: 0.65 [Ω] (Typ)
(Total of upper and lower resistors)

Package

W(Typ) x D(Typ) x H(Max)

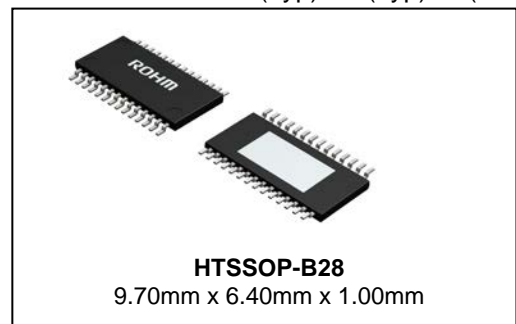

Figure 1

Typical Application Circuit

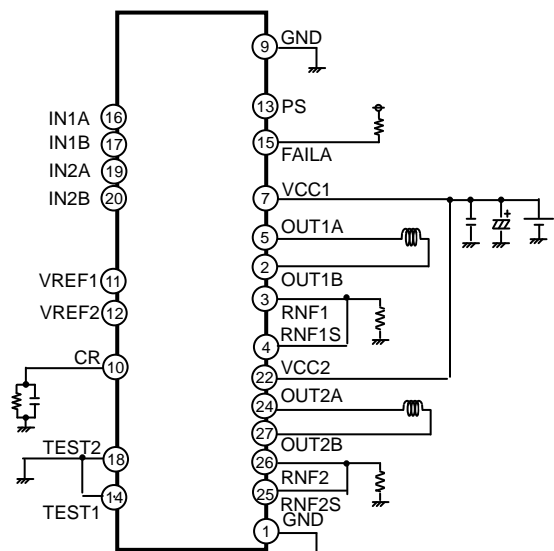

Figure 2. Typical Application Circuit

Pin Configuration

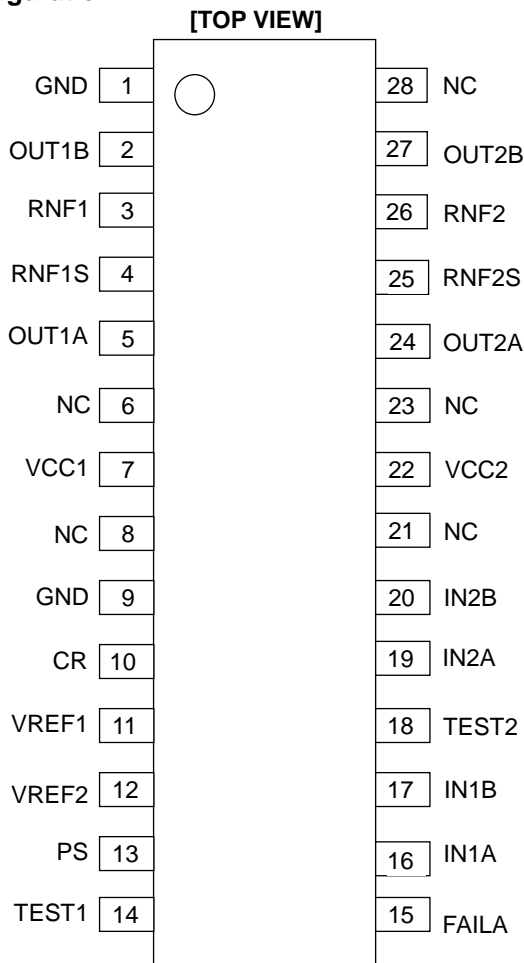

Figure 3. Pin Configuration

Block Diagram

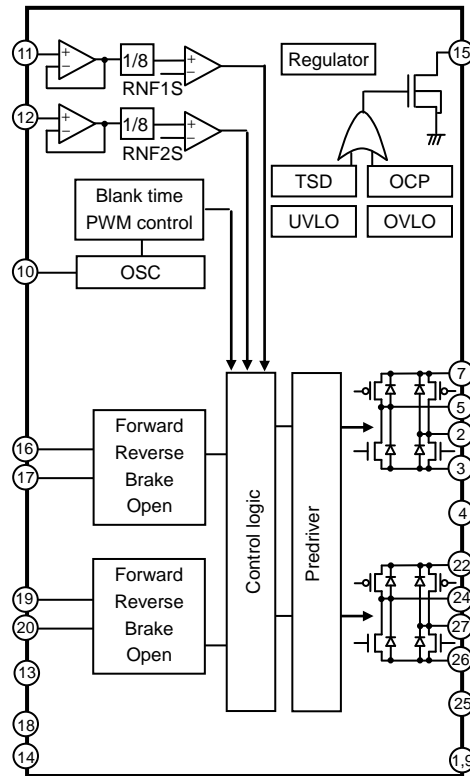

Figure 4. Block Diagram

Pin Descriptions

Pin No.	Pin Name	Function	Pin No.	Pin name	Function
1	GND	Ground terminal	15	FAILA	Output signal to detect abnormal states
2	OUT1B	H bridge output terminal	16	IN1A	H bridge control terminal
3	RNF1	Connection terminal of resistor for output current detection	17	IN1B	H bridge control terminal
4	RNF1S	Input terminal of current limit comparator	18	TEST2	Test terminal (Connected to GND)
5	OUT1A	H bridge output terminal	19	IN2A	H bridge control terminal
6	NC	No connection	20	IN2B	H bridge control terminal
7	VCC1	Power supply terminal	21	NC	No connection
8	NC	No connection	22	VCC2	Power supply terminal
9	GND	Ground terminal	23	NC	No connection
10	CR	Connection terminal of CR for setting switching frequency	24	OUT2A	H bridge output terminal
11	VREF1	Current limit value setting terminal	25	RNF2S	Input terminal of current limit comparator
12	VREF2	Current limit value setting terminal	26	RNF2	Connection terminal of resistor for output current detection
13	PS	Power save terminal	27	OUT2B	H bridge output terminal
14	TEST1	Test terminal (Connected to GND)	28	NC	No connection

Absolute Maximum Ratings (Ta=25°C)

Parameter	Symbol	Rating	Unit
Supply Voltage	V _{CC1,2}	-0.2 to +36.0	V
Power Dissipation	Pd	1.45 ^(Note 1)	W
		4.70 ^(Note 2)	W
Input Voltage for Control Pin	V _{IN}	-0.2 to +5.5	V
RNF Maximum Voltage	V _{RNF}	0.7	V
Output Current	I _{OUT}	2.0 ^(Note 3)	A/ch
Output Current (peak)	I _{OUTPEAK}	2.8 ^(Note 4)	A/ch
Operating Temperature Range	Topr	-25 to +85	°C
Storage Temperature Range	Tstg	-55 to +150	°C

(Note 1) 70mm×70mm×1.6mm glass epoxy board. Derate by 11.6mW/°C when operating above Ta=25°C.

(Note 2) 4-layer recommended board. Derate by 37.6mW/°C when operating above Ta=25°C.

(Note 3) Do not, however exceed Pd, ASO and Tjmax=150°C.

(Note 4) Pulse width tw ≤ 1ms, duty 20ms

Caution: Operating the IC over the absolute maximum ratings may damage the IC. The damage can either be a short circuit between pins or an open circuit between pins and the internal circuitry. Therefore, it is important to consider circuit protection measures, such as adding a fuse, in case the IC is operated over the absolute maximum ratings.

Recommended Operating Conditions (Ta= -25 to +85°C)

Parameter	Symbol	Range	Unit
Supply Voltage	V _{CC1,2}	8 to 28	V
Maximum Output Current (Continuous)	I _{OUT}	1.4 ^(Note 5)	A/ch

(Note 5) Do not, however exceed Pd, ASO and Tjmax=150°C.

Electrical Characteristics (Unless otherwise specified Ta=25°C, V_{CC1,2}=24V)

Parameter	Symbol	Limit			Unit	Conditions
		Min	Typ	Max		
【Whole】						
Circuit Current at Standby	I _{CCST}	-	-	10	μA	PS=L
Circuit Current	I _{CC}	-	2.5	5.0	mA	PS=H, VREFx=2V
【Control Input】						
H Level Input Voltage	V _{IN2H}	2.0	-	-	V	
L Level Input Voltage	V _{IN2L}	-	-	0.8	V	
H Level Input Current	I _{IN2H}	35	50	100	μA	V _{IN2} =5V
L Level Input Current	I _{IN2L}	-10	0	-	μA	V _{IN2} =0V
【Output (OUT1A, OUT1B, OUT2A, OUT2B)】						
Output ON-Resistance	R _{ON}	-	0.65	0.85	Ω	I _{OUT} =±1.0A (Sum of upper and lower)
Output Leak Current	I _{LEAK}	-	-	10	μA	
【Current Control】						
RNFx Input Current	I _{RNF}	-80	-40	-	μA	RNFx=0V
VREFx Input Current	I _{VREF}	-2.0	-0.1	-	μA	VREFx=0V
VREFx Input Voltage Range	V _{VREF}	0	-	2.0	V	
Minimum on Time (Blank Time)	t _{ONMIN}	0.7	1.5	3.0	μs	
Current Limit Comparator Threshold	V _{CTH}	0.23	0.25	0.27	V	VREFx=2V

Application Information

1. Points to Notice for Terminal Description and PCB Layout

(1) PS/ Power Save Terminal

PS can make circuit into standby state and make motor outputs OPEN.

Please be careful because there is a delay of 40μs (max) before it returns from OFF state to normal state.

PS	State
L	POWER SAVE (STANDBY)
H	ACTIVE

(2) IN1A, IN1B, IN2A, IN2B/ H Bridge Control Terminal

It decides output logic for H bridge.

PS	Input		Output		State
	IN1A IN2A	IN1B IN2B	OUT1A OUT2A	OUT1B OUT2B	
L	X	X	OPEN	OPEN	POWER SAVE (STANDBY)
H	L	L	OPEN	OPEN	STOP
H	H	L	H	L	FORWARD
H	L	H	L	H	REVERSE
H	H	H	L	L	BRAKE

X: H or L

(3) TEST1, TEST2/ Terminal for Testing

This is the terminal used at the time of distribution test. Please connect to GND. Please be careful because there is a possibility of malfunction if it is not connected to GND.

(4) VCC1, VCC2/ Power Supply Terminal

Motor's drive current is flowing in it, so please connect it in such a way that the wire is thick & short and has low impedance. VCC voltage may have great fluctuation, so please connect the bypass capacitor (100uF to 470uF) as close as possible to the terminal. Adjust in such a way that the VCC voltage is stable. Please increase the capacitance if needed, especially when large current or motors that have great back electromotive force are used. In addition, to reduce the power supply's impedance in wide frequency bandwidth, parallel connection of multi-layered ceramic capacitor (0.01μF to 0.1μF) is recommended. Extreme care must be observed to make sure that the VCC voltage does not exceed the rating even for a moment. VCC1 & VCC2 are shorted inside IC, so please be sure to short VCC1 & VCC2 externally when using. If used without shorting, malfunction or destruction may occur because of concentration of current routes etc., so please make sure that they are shorted when in use. Moreover, there is a built-in clamp component in the output terminal to prevent electrostatic destruction. If sudden pulse or surge voltage of more than the maximum absolute rating is applied, the clamp component operates which can result to destruction. Please be sure to not exceed the maximum absolute rating. It is effective to mount a Zener diode with maximum absolute rating. Also, diode is inserted between VCC terminal and GND terminal to prevent electrostatic destruction. If reverse voltage is applied between VCC terminal and GND terminal, there is a danger of IC destruction so please be careful.

(5) GND/ Ground Terminal

In order to reduce the noise caused by switching current and to stabilize the internal reference voltage of IC, please connect it in such a way that the wiring impedance from this terminal is made as low as possible to achieve the lowest electrical potential no matter what operating state it may be.

(6) OUT1A, OUT1B, OUT2A, OUT2B/ H Bridge Output Terminal

Motor's drive current is flowing in it, so please connect it in such a way that the wire is thick & short and has low impedance. It is also effective to add a Schottky diode if output has great positive or negative fluctuation when large current is applied. For example, a counter electromotive voltage etc. is great. Moreover, there is a built-in clamp component in the output terminal to prevent electrostatic destruction. If sudden pulse or surge voltage of more than the maximum absolute rating is applied, the clamp component operates which can result to destruction. Please be sure to not exceed the maximum absolute rating.

(7) RNF1, RNF2/ Connection Terminal of Resistor for Detecting of Output Current

Please connect the resistor of 0.1Ω to 0.3Ω for current detection between this terminal and GND according to application circuits (Figure 3,4) and consider the power consumption of the current-detecting resistor. Determine the resistor in such a way that $W=I_{OUT}^2 \cdot R[W]$ does not exceed the power dissipation of the resistor. In addition, please connect it in such a way that it has low impedance and does not have impedance in common with other GND patterns. This is because motor's drive current flows in the pattern through RNF terminal to current-detecting resistor to GND. Please do not exceed the rating because there is the possibility of circuits' malfunction etc. if the RNF voltage has exceeded the maximum rating (0.7V). Moreover, please be careful not to short RNF terminal to GND because there is the danger that OCP or TSD will operate when large current flows without normal PWM constant current control.. However, if RNF terminal is open, there is also the possibility of malfunction because output current does not flow either. Please do not let it open.

(8) RNF1S,RNF2S/ Input Terminal of Current Limit Comparator

In this series, RNFS terminal, which is the input terminal of current limit comparator, is independently arranged in order to decrease the lowering of current-detection accuracy caused by the wire impedance inside the IC of RNF terminal. Therefore, please make sure to connect RNF terminal and RNFS terminal together when using PWM constant current control. In addition, in case of interconnection, the lowering of current-detection accuracy caused by the impedance of board pattern between RNF terminal and the current-detecting resistor can be decreased because the wires from RNFS terminal is connected near the current-detecting resistor. Moreover, please design the pattern in such a way that there is no noise spike.

(9) VREF1,VREF2/ Output Current Value-setting Terminal

This is the terminal to set the output current value for PWM constant current control or motor locking. The output current value can be set by VREF voltage and current-detecting resistor (RNF resistor).

$$\text{Output current } I_{OUT}[A] = \{VREF[V] / 8(\text{division ratio inside IC})\} / RNF [\Omega]$$

Please avoid using it with VREF terminal open. If VREF terminal is open, there is possibility of malfunctions as the setting current increases and a large current flows etc. This is caused by unstable input and increasing VREF voltage. Please take note of the input voltage range because if voltage of over 2V is applied on VREF terminal, there is also a danger that large current flows in the output and OCP or TSD will operate. Also, when selecting the resistance value please take into consideration the outflow current (max 2μA) produced by resistance division. The minimum current, which can be controlled by VREF voltage, is determined by motor coil's L & R values and minimum ON time. There is a minimum ON time in PWM drive.

(10) CR/ Connection terminal of CR for Setting Switching Frequency

This is the terminal to set the switching frequency of the output. Please connect the external C (330pF to 680pF) and R (10kΩ to 150kΩ) between this terminal and GND. Please refer to page 8.

Please connect the external components to GND in such a way that the interconnection does not have impedance in common with other GND patterns. In addition, please create the pattern design in such a way to keep such sudden pulses as square wave etc. away and that there is no noise spike. Please mount the two components of C and R if PWM constant current control is being used. This is because normal PWM constant current control cannot be used if CR terminal is open or it is biased externally. When not using PWM constant current control, connect this terminal to GND.

(11) FAILA/ Fault Signal Output Terminal

FAILA outputs low signal when Over-Current Protection (OCP) or Thermal Shutdown (TSD) operates.

Even if Under Voltage Lock Out (UVLO) or Over Voltage Lock Out (OVLO) operates, FAILA signal doesn't turn low (i.e. high).

This terminal is an open drain type, so please set the pull up resistor (5kΩ to 100kΩ) to power supply less than 7V (i.e. 5V or 3.3V). If not using this terminal, please connect it to GND.

OCP	TSD	FAILA
OFF	OFF	H (OFF)
OFF	ON	M (ON)
ON	OFF	L (ON)
ON	ON	L (ON)

(12) NC Terminal

This terminal is unconnected electrically with IC internal circuit.

(13) IC Back Metal

For HTSSOP-B28 package, the metal heat sink is mounted on IC's back side. It becomes a prerequisite to use this metal as heat sink so please secure the heat sink area sufficiently by soldering it to the GND plane on the board. Get as wide GND pattern as possible. Please be careful because the allowable power dissipation as shown in page 14 cannot be attained if the metal heat sink is not connected by solder. Moreover, the back side metal is shorted with IC chip's back side and it becomes the GND potential, so there is a danger of malfunction and destruction if it is shorted with potentials other than GND. Therefore; please do not design patterns other than GND through the IC's back side.

Protection Circuits

(14) Thermal Shutdown (TSD)

This IC has a built-in Thermal Shutdown circuit for thermal protection. When the IC's chip temperature rises above 175°C (Typ), the motor output becomes OPEN. Also, when the temperature returns to under 150°C (Typ), it automatically returns to normal operation. However, even when TSD is in operation, if heat is continued to be applied externally, heat overdrive can lead to destruction.

(15) Over-Current Protection (OCP)

This IC has a built in Over-Current Protection circuit as a provision against destruction when the motor outputs are shorted to each other or VCC-motor output or motor output-GND is shorted. This circuit latches the motor output to OPEN condition when the regulated threshold current flows for 4 μ s (typ). It returns with power reactivation or a reset of the PS terminal. The over-current protection circuit aims to prevent the destruction of the IC only from abnormal situations such as when motor output is shorted and it is not meant to be used as protection or security for the device. Therefore, the device should not be designed to make use of the function of this circuit. After OCP operation, if abnormal situations continues and returned by power reactivation or reset of the PS terminal happens repeatedly, then OCP operates constantly. The IC may generate heat or otherwise deteriorate. When the L value of the wiring is great due to the long wiring and the over-current flows, the output terminal voltage increases and the absolute maximum values may be exceeded. As a result, there is a possibility of destruction. Also, when a current flows, which is over the output current rating and under the OCP detection current, the IC can heat up to over T_{jmax}=150°C. This can deteriorate the IC. Therefore, current which exceeds the output rating should not be applied.

(16) Under Voltage Lock Out (UVLO)

This IC has a built-in Under Voltage Lock Out function to prevent false operation such as IC output during power supply under voltage. When the applied voltage to the VCC terminal goes under 5V (Typ), the motor output is set to OPEN. This switching voltage has a 1V (Typ) hysteresis to prevent false operation by noise etc. Please be aware that this protection circuit does not operate during power save mode.

(17) Over Voltage Lock Out (OVLO)

This IC has a built-in Over Voltage Lock Out function to protect the IC output and the motor during power supply over voltage. When the applied voltage to the VCC terminal goes over 32V (Typ), the motor output is set to OPEN. This switching voltage has a 1V (Typ) hysteresis and a 4 μ s (Typ) mask time to prevent false operation by noise etc. Although this over voltage locked out circuit is built-in, there is a possibility of destruction if the absolute maximum value for power supply voltage is exceeded. Therefore, the absolute maximum value should not be exceeded. Please be aware that this protection circuit does not operate during power save mode.

(18) Ghost Supply Prevention (protects against malfunction when power supply is disconnected)

If a control signal (IN1A, IN1B, IN2A, IN2B, PS, VREF1, VREF2) is applied when there is no power supplied to the IC, there is a function which prevents false operation by voltage applied via the electrostatic destruction prevention diode from the control input terminal to the VCC, to this IC or to another IC's power supply. Therefore, there is no malfunction in the circuit even when voltage is supplied to these input terminals while there is no power supply.

2. External PWM Control

This series can drive motors by IN1A, IN1B, IN2A, and IN2B input directly from the microcomputer (up to 100kHz). Decay mode can be SLOW DECAY or FAST DECAY.

SLOW DECAY (forward rotation)

PS	Input		Output		State
	IN1A IN2A	IN1B IN2B	OUT1A OUT2A	OUT1B OUT2B	
H	H	L	H	L	ON
H	H	H	L	L	SLOW DECAY
H	H	L	H	L	ON
H	H	H	L	L	SLOW DECAY
H	H	L	H	L	ON

FAST DECAY (synchronous rectification, forward rotation)

PS	Input		Output		State
	IN1A IN2A	IN1B IN2B	OUT1A OUT2A	OUT1B OUT2B	
H	H	L	H	L	ON
H	L	H	L	H	FAST DECAY
H	H	L	H	L	ON
H	L	H	L	H	FAST DECAY
H	H	L	H	L	ON

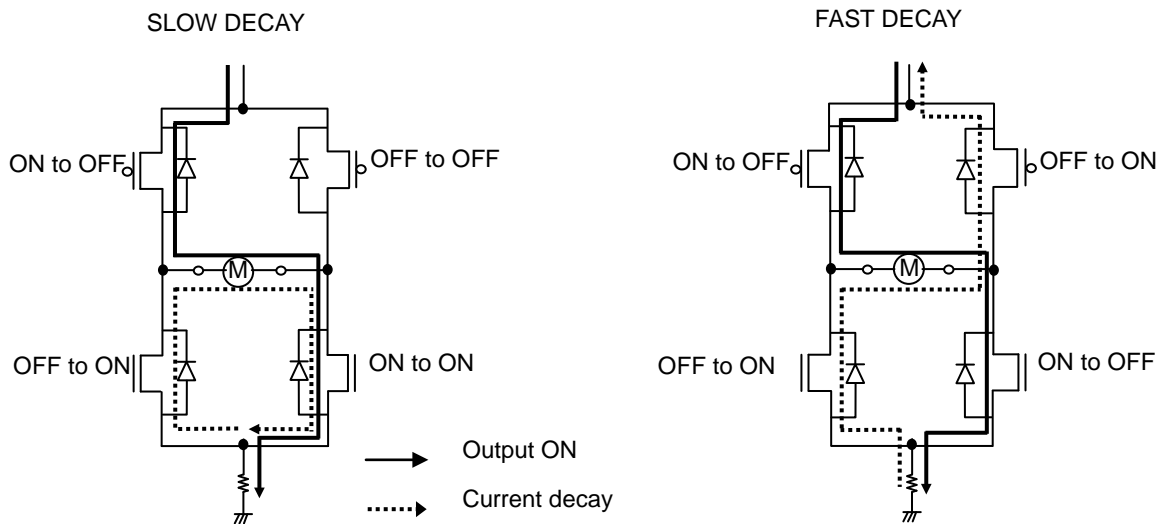

Figure 5. Route of Regenerative Current during Current Decay

3. PWM Constant Current Control

This function can limit the peak current or switching current in driving DC brush motor. In addition, it can drive bipolar stepper motor by PWM constant current control.

(1) Current Control Operation

When the output transistor is turned on, the output current increases which raises the voltage over the current sense resistor. When the voltage on the RNF pin reaches the voltage value set by the VREF input voltage, the current limit comparator operates and enters current decay mode. The output is then held OFF for a period of time determined by the RC time constant connected to the CR pin. The process repeats itself constantly for PWM operation.

(2) Blank Time (Fixed in Internal Circuit)

In order to avoid misdetection of output current due to RNF spikes that may occur when the output turns ON, the IC employs an automatic current detection-masking period (t_{ONMIN} 1.5 μ s typ). During this period, the current detection is disabled immediately after the output transistor is turned on. This allows for constant-current drive without the need for an external filter.

(3) CR Timer

The CR component connected to the CR pin is repeatedly charged and discharged between the VCRH and VCRL levels. The CR continues to discharge during this period until it reaches VCRL, at which point the IC output is switched back ON.

The CR charge time (t_{charge}) and discharge time ($t_{discharge}$) are set by external components, according to the following formulas. The total of t_{charge} and $t_{discharge}$ yield the switching period, t_{switch} .

$$t_{charge} [s] = C \cdot R' \cdot R / (R' + R) \cdot \ln[(V_{CR} - 0.4) / (V_{CR} - 1.0)]$$

$$V_{CR} = V \cdot R / (R' + R)$$

where:
 V is the internal regulator voltage 5V(typ)
 R' is the CR internal impedance 5k Ω (typ)

$$t_{discharge} [s] = C \cdot R \cdot \ln[(1 + \alpha) / 0.4]$$

α : See the right graph

$$t_{CHOP} [s] = t_{charge} + t_{discharge}$$

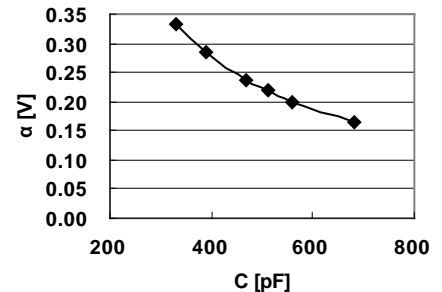

Setting range: C (330pF to 680pF), R (10k Ω to 150k Ω)

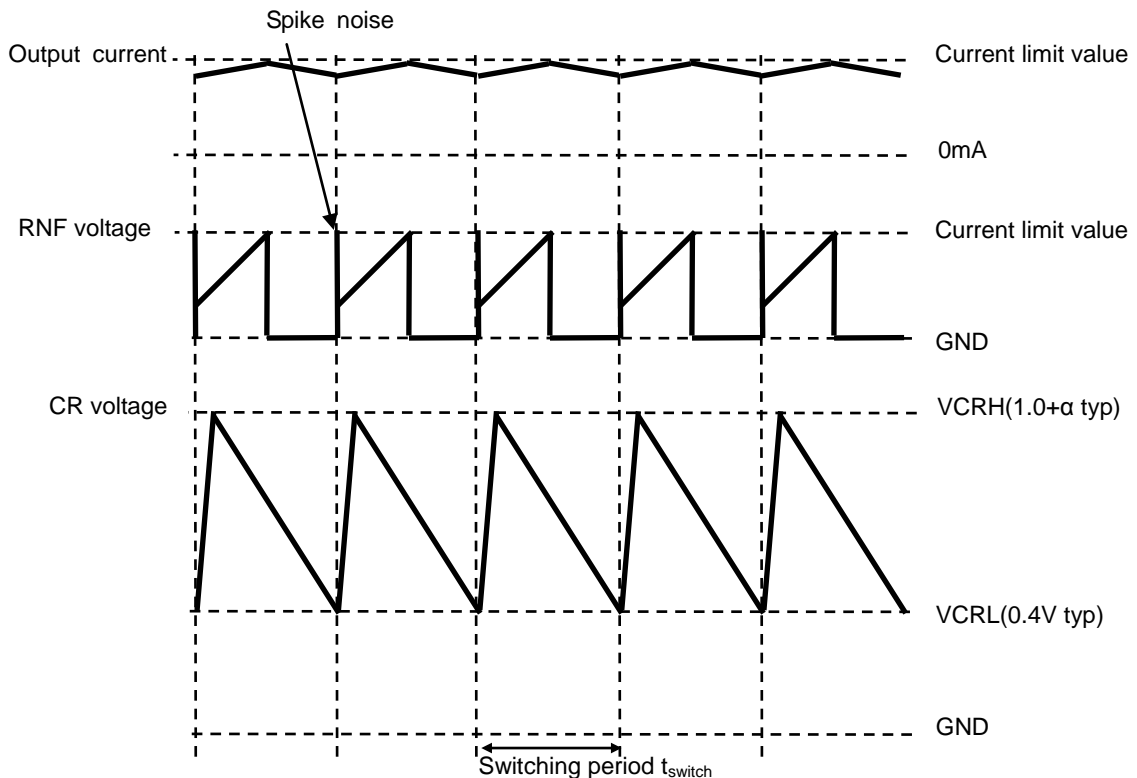

Figure 6. Timing Chart of CR Voltage, RNF Voltage and Output Current

4. Control Sequence of Stepper Motor

The following sequence can control the stepper motor by FULL STEP or HALF STEP mode.

Example of control sequence and torque vector

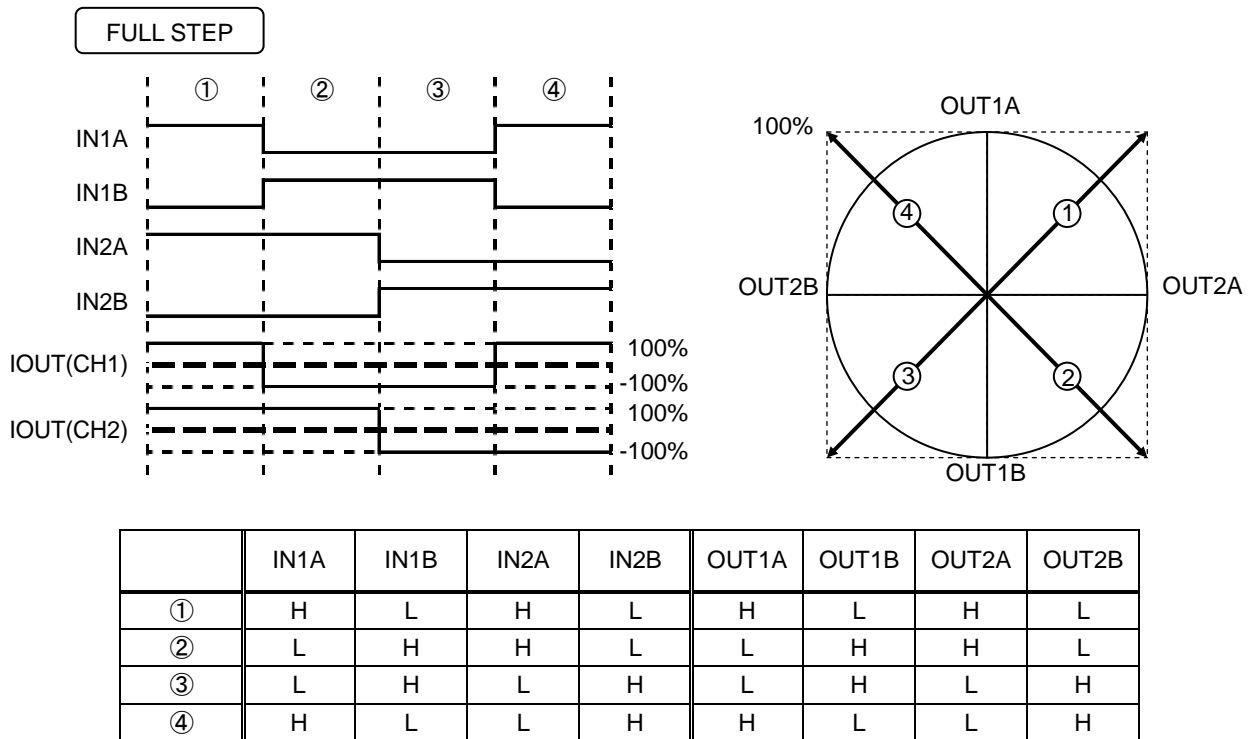

Figure 7. FULL STEP Control Sequence

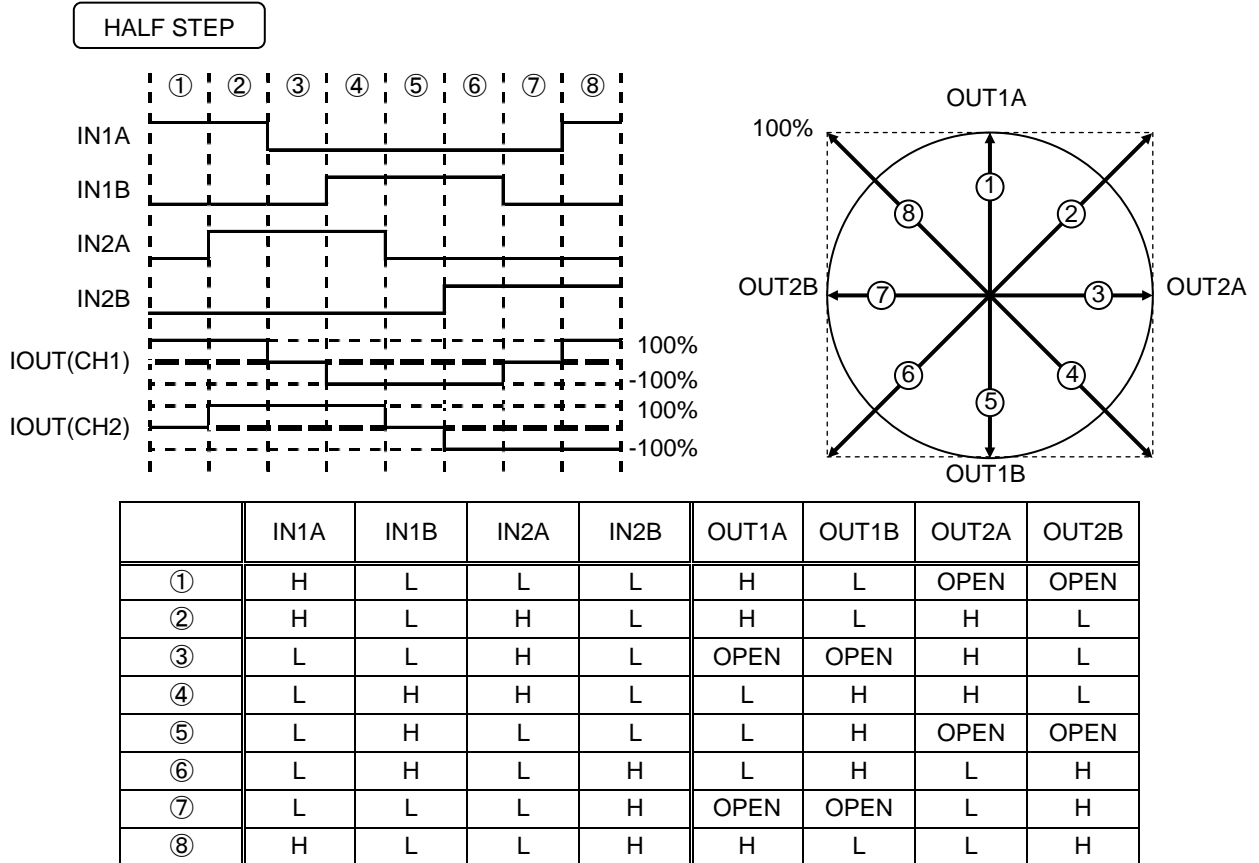

Figure 8. HALF STEP Control Sequence

5. μ STEP Drive for Stepper Motor

Output current of channel 1 and channel 2 can be determined by VREF1, VREF2. Output logic can be done by IN1A, IN1B, IN2A, IN2B. Therefore, linear voltage input by external DAC to VREF1, VREF2 enables to drive stepper motor in μ STEP mode.

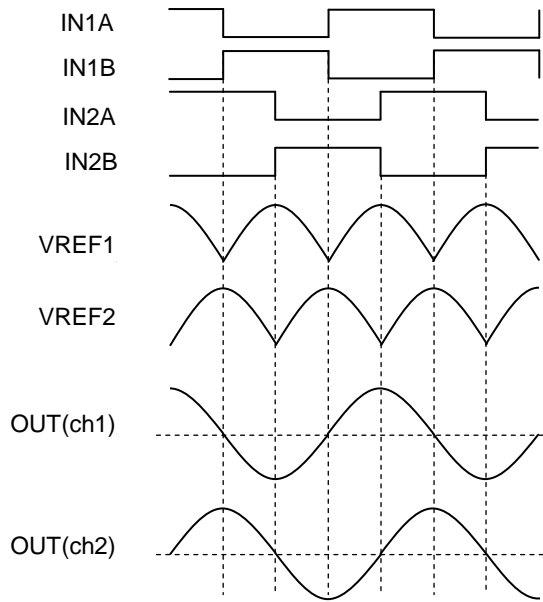

Figure 9. μ STEP Control Sequence and Output Current

6. Power Dissipation

Please confirm that the IC's chip temperature T_j is not over 150°C . Consider the IC's power consumption (W), package power (P_d) and ambient temperature (T_a). When $T_j=150^\circ\text{C}$ is exceeded, the functions as a semiconductor do not operate and problems such as parasitic and leaks occur. Constant use under these conditions leads to deterioration and eventually destruction of the IC. $T_{jmax}=150^\circ\text{C}$ must be strictly obeyed under all circumstances.

(1) Thermal Calculation

The IC's consumed power can be estimated roughly with the power supply voltage (V_{CC}), circuit current (I_{CC}), output ON-Resistance (R_{ONH} , R_{ONL}) and motor output current value (I_{OUT}).

The calculation method during external PWM drive, SLOW DECAY, driving channel 1 only is shown here:

When using both channel 1 and channel 2, calculate for each H bridge.

$$\text{Consumed power of the } V_{CC} [W] = V_{CC} [V] \cdot I_{CC} [A] \dots\dots\dots \textcircled{1}$$

$$\text{Consumed power of the output DMOS } [W] = \frac{(R_{ONH}[\Omega] + R_{ONL}[\Omega]) \cdot I_{OUT} [A]^2 \cdot \text{on_duty} [\%] / 100}{\text{During output ON}} + \frac{(2 \cdot R_{ONL}[\Omega]) \cdot I_{OUT} [A]^2 \cdot (100 - \text{on_duty} [\%] / 100)}{\text{During current decay}} \dots\dots \textcircled{2}$$

However, on duty: PWM on duty [%]

Model Number	Upper P-Channel DMOS ON-Resistance $R_{ONH}[\Omega]$ (Typ)	Lower N-Channel DMOS ON-Resistance $R_{ONL}[\Omega]$ (Typ)
BD62220AEFV	0.4	0.25

$$\text{Consumed total power of IC } W_{\text{total}} [W] = \textcircled{1} + \textcircled{2}$$

$$\text{Junction temperature } T_j [^\circ\text{C}] = T_a [^\circ\text{C}] + \theta_{ja} [^\circ\text{C/W}] \cdot W_{\text{total}} [W]$$

However, the thermal resistance value θ_{ja} [$^\circ\text{C/W}$] differs significantly depending on circuit board conditions. Refer to the Power Dissipation curve on page 14. Also, we are taking measurements of thermal resistance value θ_{ja} of the actual boards used. Please feel free to contact our salesman. The calculated values above are only theoretical. For actual thermal design, please perform sufficient thermal evaluation for the application board used, and create the thermal design with enough margin to not exceed $T_{jmax}=150^\circ\text{C}$. Although not normally used, if the IC is to be used under specific or strict heat conditions, please consider attaching an external Schottky diode between the motor output terminal and GND to decrease heat from the IC.

(2) Temperature Monitoring

There is a way to directly measure the approximate chip temperature by using the TEST2 terminal. However, temperature monitor using TEST2 terminal is only for evaluation and experimenting, and must not be used in actual usage conditions. TEST2 terminal has a protection diode to prevent electrostatic discharge. The temperature may be monitored using this protection diode.

- (a) Measure the terminal voltage when a current of $I_{DIODE}=50\mu A$ flows from the TEST2 terminal to the GND, without supplying VCC to the IC. This measurement is the V_F voltage inside the diode.
- (b) Measure the temperature characteristics of this terminal voltage. (V_F has a linear negative temperature factor against the temperature.) With the results of these temperature characteristics, chip temperature may be calibrated from the TEST terminal voltage.
- (c) Supply VCC, confirm the TEST2 terminal voltage while running the motor, and the chip temperature can be approximated from the results of (b).

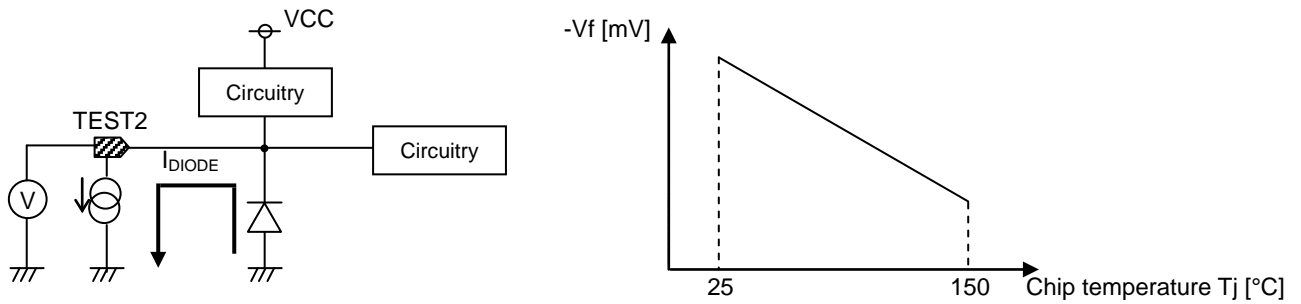

Figure 10. Model Diagram for Measuring Chip Temperature

7. Application Circuit Diagram

(1) Constant Voltage Control or External PWM Control

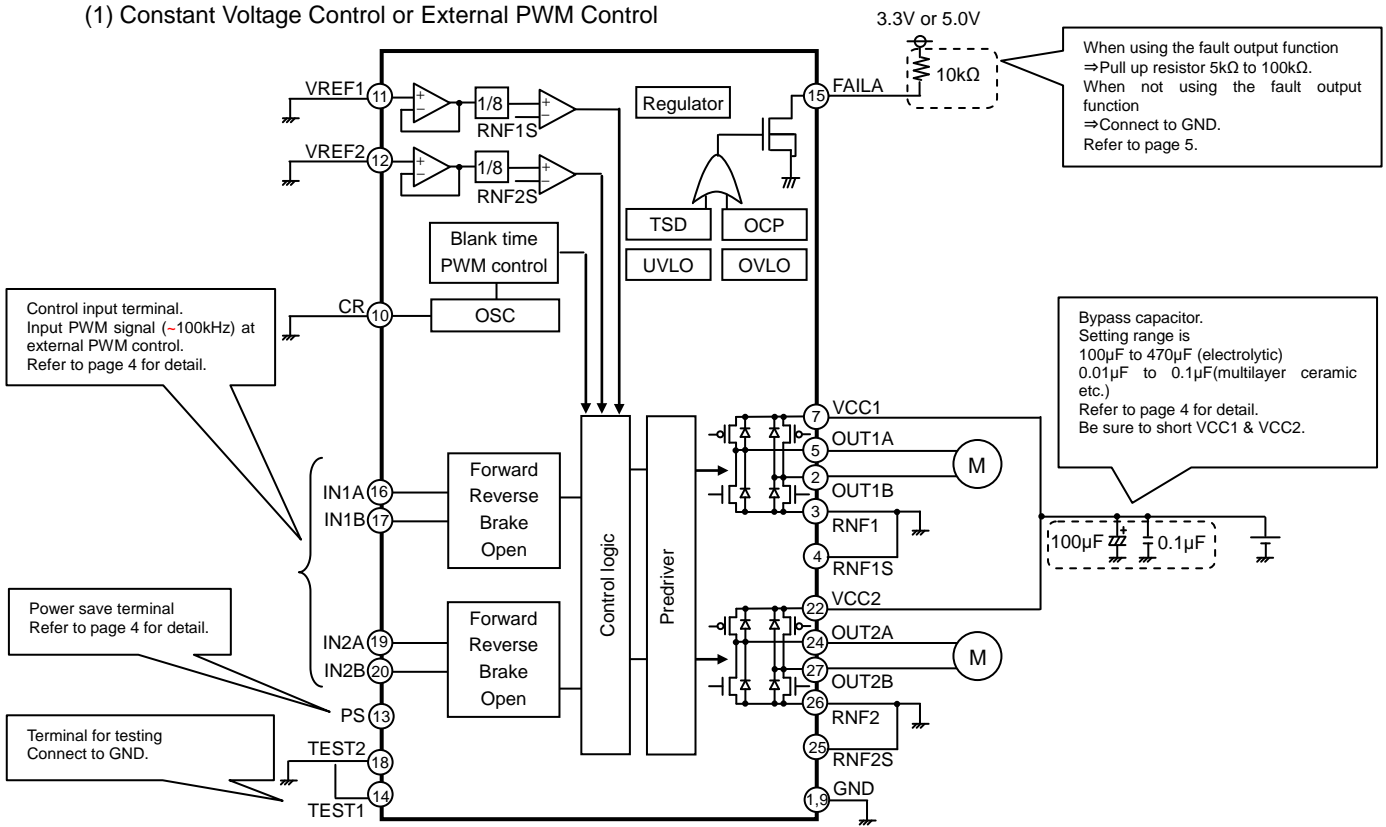

Figure 11. Block Diagram & Application Circuit Diagram

(a) Input/Output table

PS	Input		Output		State
	IN1A IN2A	IN1B IN2B	OUT1A OUT2A	OUT1B OUT2B	
L	X	X	OPEN	OPEN	POWER SAVE (STANDBY)
H	L	L	OPEN	OPEN	STOP
H	H	L	H	L	FORWARD
H	L	H	L	H	REVERSE
H	H	H	L	L	BRAKE

X: H or L

(b) Example of external PWM control sequence
SLOW DECAY (forward rotation)

PS	Input		Output		State
	IN1A IN2A	IN1B IN2B	OUT1A OUT2A	OUT1B OUT2B	
H	H	L	H	L	ON
H	H	H	L	L	SLOW DECAY
H	H	L	H	L	ON
H	H	H	L	L	SLOW DECAY
H	H	L	H	L	ON

FAST DECAY (forward rotation)

PS	Input		Output		State
	IN1A IN2A	IN1B IN2B	OUT1A OUT2A	OUT1B OUT2B	
H	H	L	H	L	ON
H	L	H	L	H	FAST DECAY
H	H	L	H	L	ON
H	L	H	L	H	FAST DECAY
H	H	L	H	L	ON

(2) PWM Constant Current Control

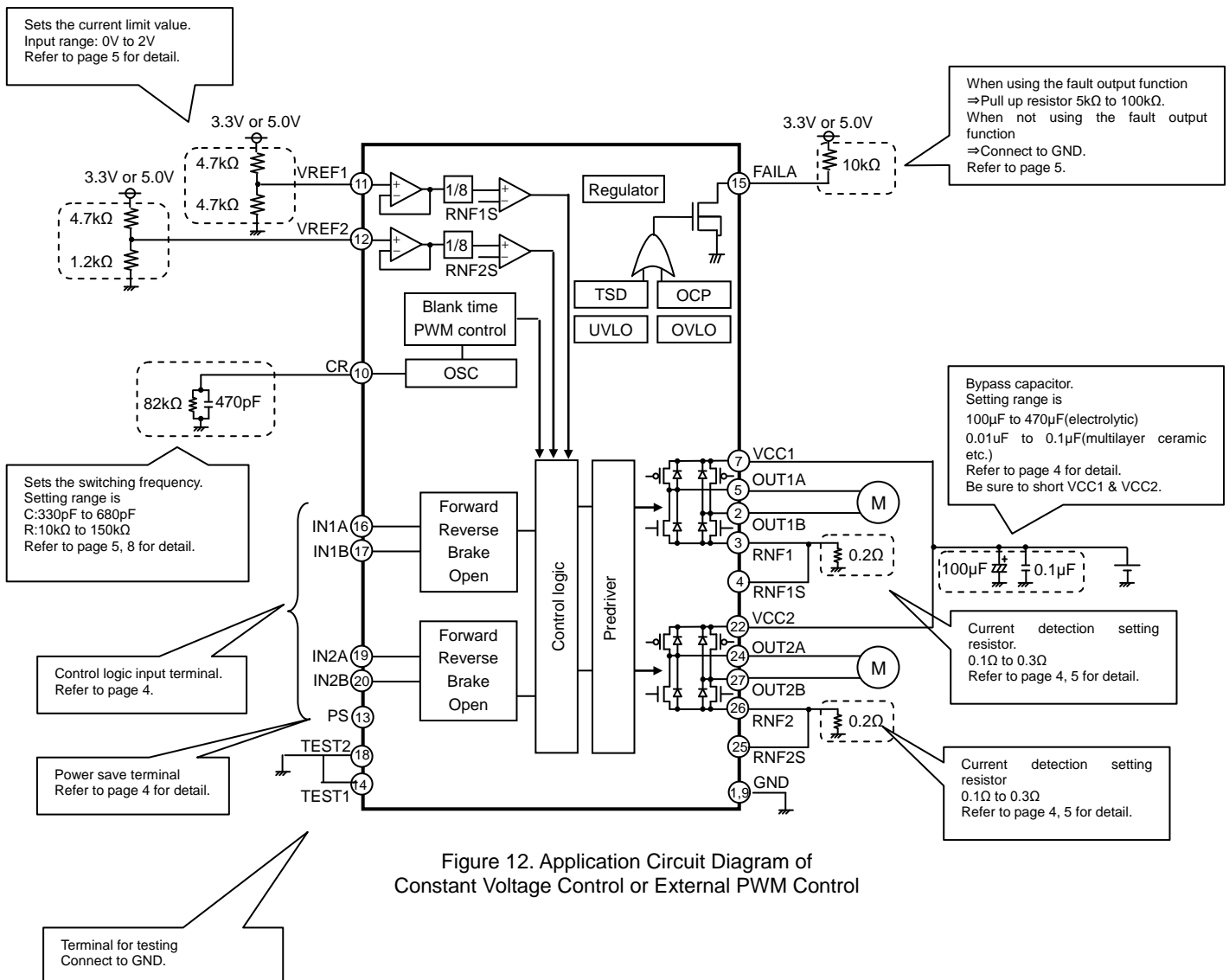

Figure 12. Application Circuit Diagram of Constant Voltage Control or External PWM Control

(a) Input/Output table

Input			Output			State
PS	IN1A IN2A	IN1B IN2B	OUT1A OUT2A	OUT1B OUT2B		
L	X	X	OPEN	OPEN		POWER SAVE (STANDBY)
H	L	L	OPEN	OPEN		STOP
H	H	L	H	L		FORWARD
H	L	H	L	H		REVERSE
H	H	H	L	L		BRAKE

X: H or L

I/O Equivalent Circuits

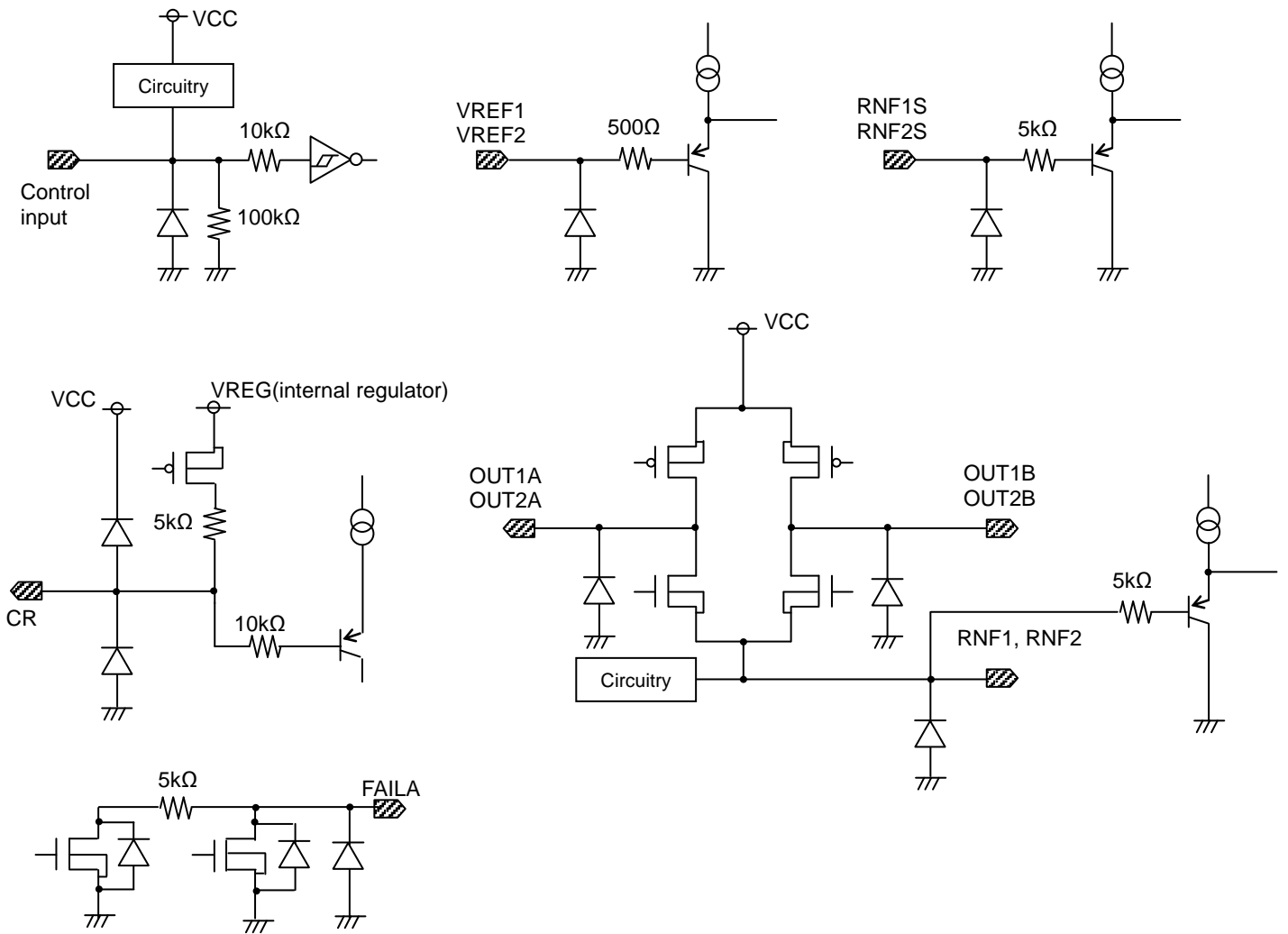

Figure 14. I/O Equivalent Circuits

Operation Notes

- 1. Reverse Connection of Power Supply**

Connecting the power supply in reverse polarity can damage the IC. Take precautions against reverse polarity when connecting the power supply, such as mounting an external diode between the power supply and the IC's power supply terminals.
- 2. Power Supply Lines**

Design the PCB layout pattern to provide low impedance supply lines. Separate the ground and supply lines of the digital and analog blocks to prevent noise in the ground and supply lines of the digital block from affecting the analog block. Furthermore, connect a capacitor to ground at all power supply pins. Consider the effect of temperature and aging on the capacitance value when using electrolytic capacitors.
- 3. Ground Voltage**

Ensure that no pins are at a voltage below that of the ground pin at any time, even during transient condition.
- 4. Ground Wiring Pattern**

When using both small-signal and large-current ground traces, the two ground traces should be routed separately but connected to a single ground at the reference point of the application board to avoid fluctuations in the small-signal ground caused by large currents. Also ensure that the ground traces of external components do not cause variations on the ground voltage. The ground lines must be as short and thick as possible to reduce line impedance.
- 5. Thermal Consideration**

Should by any chance the power dissipation rating be exceeded, the rise in temperature of the chip may result in deterioration of the properties of the chip. The absolute maximum rating of the Pd stated in this specification is when the IC is mounted on a 70mm x 70mm x 1.6mm glass epoxy board. In case of exceeding this absolute maximum rating, increase the board size and copper area to prevent exceeding the Pd rating.
- 6. Recommended Operating Conditions**

These conditions represent a range within which the expected characteristics of the IC can be approximately obtained. The electrical characteristics are guaranteed under the conditions of each parameter.
- 7. Inrush Current**

When power is first supplied to the IC, it is possible that the internal logic may be unstable and inrush current may flow instantaneously due to the internal powering sequence and delays, especially if the IC has more than one power supply. Therefore, give special consideration to power coupling capacitance, power wiring, width of ground wiring, and routing of connections.
- 8. Operation Under Strong Electromagnetic Field**

Operating the IC in the presence of a strong electromagnetic field may cause the IC to malfunction.
- 9. Testing on Application Boards**

When testing the IC on an application board, connecting a capacitor directly to a low-impedance output pin may subject the IC to stress. Always discharge capacitors completely after each process or step. The IC's power supply should always be turned OFF completely before connecting or removing it from the test setup during the inspection process. To prevent damage from static discharge, ground the IC during assembly and use similar precautions during transport and storage.
- 10. Inter-pin Short and Mounting Errors**

Ensure that the direction and position are correct when mounting the IC on the PCB. Incorrect mounting may result in damaging the IC. Avoid nearby pins being shorted to each other especially to ground, power supply and output pin. Inter-pin shorts could be due to many reasons such as metal particles, water droplets (in very humid environment) and unintentional solder bridge deposited in between pins during assembly to name a few.
- 11. Unused Input Terminals**

Input terminals of an IC are often connected to the gate of a MOS transistor. The gate has extremely high impedance and extremely low capacitance. If left unconnected, the electric field from the outside can easily charge it. The small charge acquired in this way is enough to produce a significant effect on the conduction through the transistor and cause unexpected operation of the IC. So unless otherwise specified, unused input terminals should be connected to the power supply or ground line.

Operation Notes – continued

12. Regarding Input Pins of the IC

This monolithic IC contains P+ isolation and P substrate layers between adjacent elements in order to keep them isolated. P-N junctions are formed at the intersection of the P layers with the N layers of other elements, creating a parasitic diode or transistor. For example (refer to figure below):

When $GND > Pin A$ and $GND > Pin B$, the P-N junction operates as a parasitic diode.
 When $GND > Pin B$, the P-N junction operates as a parasitic transistor.

Parasitic diodes inevitably occur in the structure of the IC. The operation of parasitic diodes can result in mutual interference among circuits, operational faults, or physical damage. Therefore, conditions that cause these diodes to operate, such as applying a voltage lower than the GND voltage to an input pin (and thus to the P substrate) should be avoided.

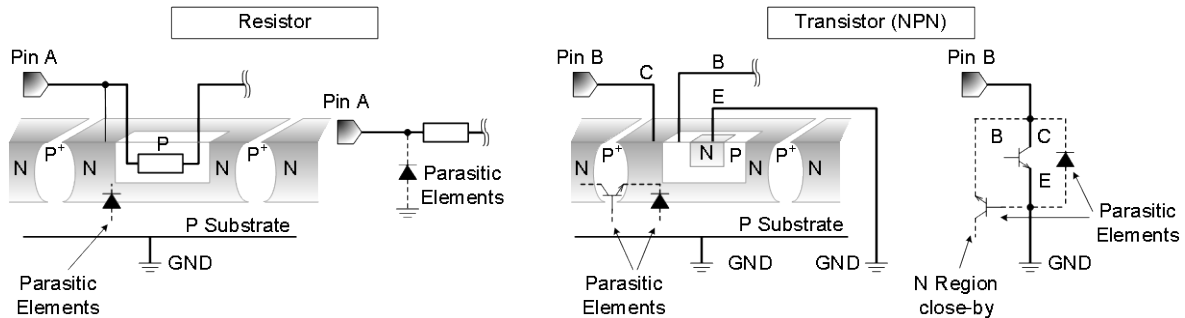

Figure 15. Example of Monolithic IC Structure

13. Area of Safe Operation (ASO)

Operate the IC such that the output voltage, output current, and power dissipation are all within the Area of Safe Operation (ASO).

14. Thermal Shutdown Circuit(TSD)

This IC has a built-in thermal shutdown circuit that prevents heat damage to the IC. Normal operation should always be within the IC's power dissipation rating. If however the rating is exceeded for a continued period, the junction temperature (Tj) will rise which will activate the TSD circuit that will turn OFF all output pins. When the Tj falls below the TSD threshold, the circuits are automatically restored to normal operation.

Note that the TSD circuit operates in a situation that exceeds the absolute maximum ratings and therefore, under no circumstances, should the TSD circuit be used in a set design or for any purpose other than protecting the IC from heat damage.

15. Over-Current Protection Circuit (OCP)

This IC has a built-in over-current protection circuit that activates when the output is accidentally shorted. However, it is strongly advised not to subject the IC to prolonged shorting of the output.

16. Operation Under Strong Electromagnetic Field (BD62220AEFV)

Operating the IC in the presence of a strong electromagnetic field may cause the IC to malfunction.

17. The Back Side of the IC Package (Define the side where product markings are printed as front) (BD62220AEFV)

There is an exposed central pad on the back side of the IC package. Please mount by footprint dimensions described in the Jisso Information for WSO5F5. Connect it to ground. If it is not connected to ground, there is a possibility that the device malfunctions or a large current is generated.

18. TEST Terminal (BD62220AEFV)

Be sure to connect TEST pin to GND.

Power Dissipation

HTSSOP-B28

HTSSOP-B28 has exposed metal on the back. It is possible to dissipate heat using the through holes in the back of board as well as the surfaces with large areas of copper foil heat dissipation patterns which greatly increases power dissipation. The back metal is shorted to the back side of the IC chip, being a GND potential, therefore there is a possibility for malfunction if it is shorted with any potential other than GND. It should be avoided. Also, it is recommended that the back metal is soldered onto the GND. Please note that it has been assumed that this product will be used in the condition wherein this back metal has undergone heat dissipation treatment to increase heat dissipation efficiency.

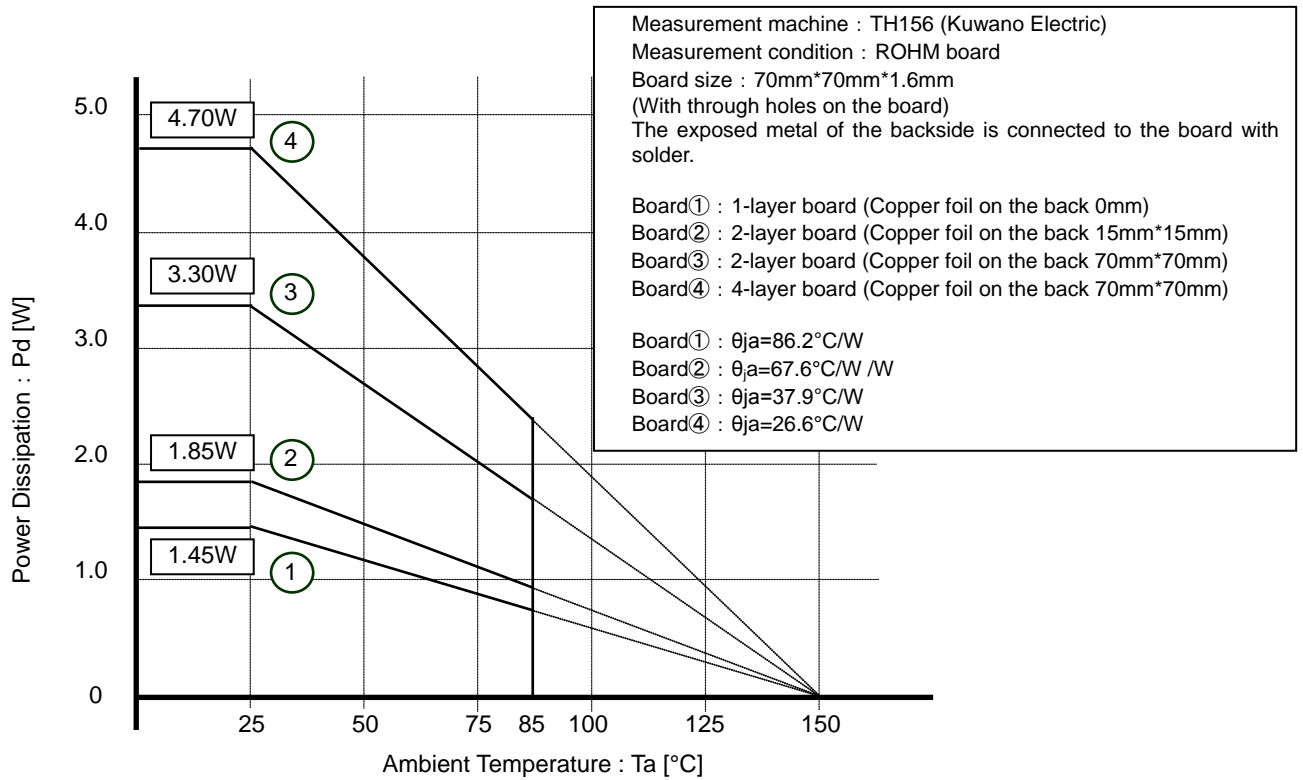
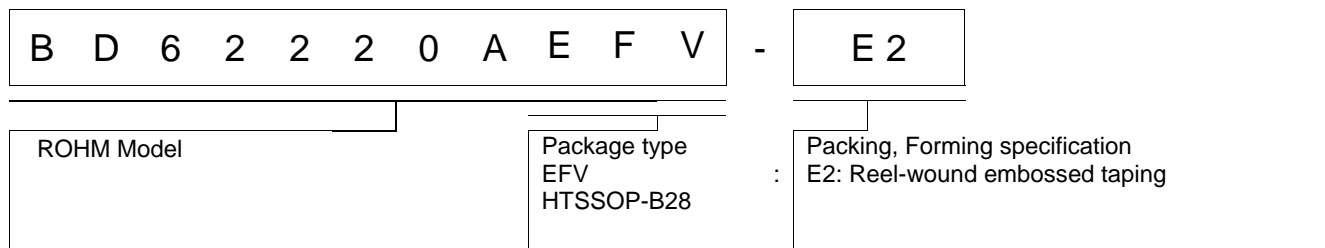
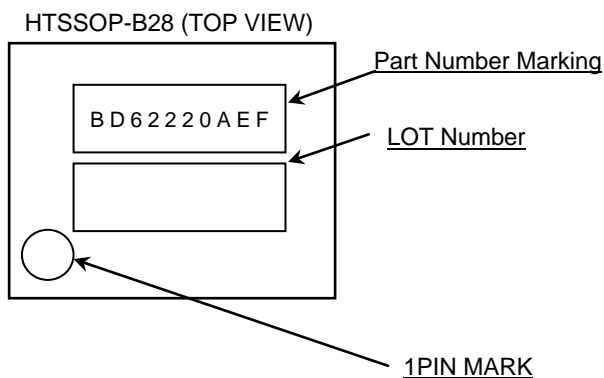

Figure 13. HTSSOP-B28 Power Dissipation

Selecting a model name when ordering



• Marking Diagram



Physical Dimension, Tape and Reel Information

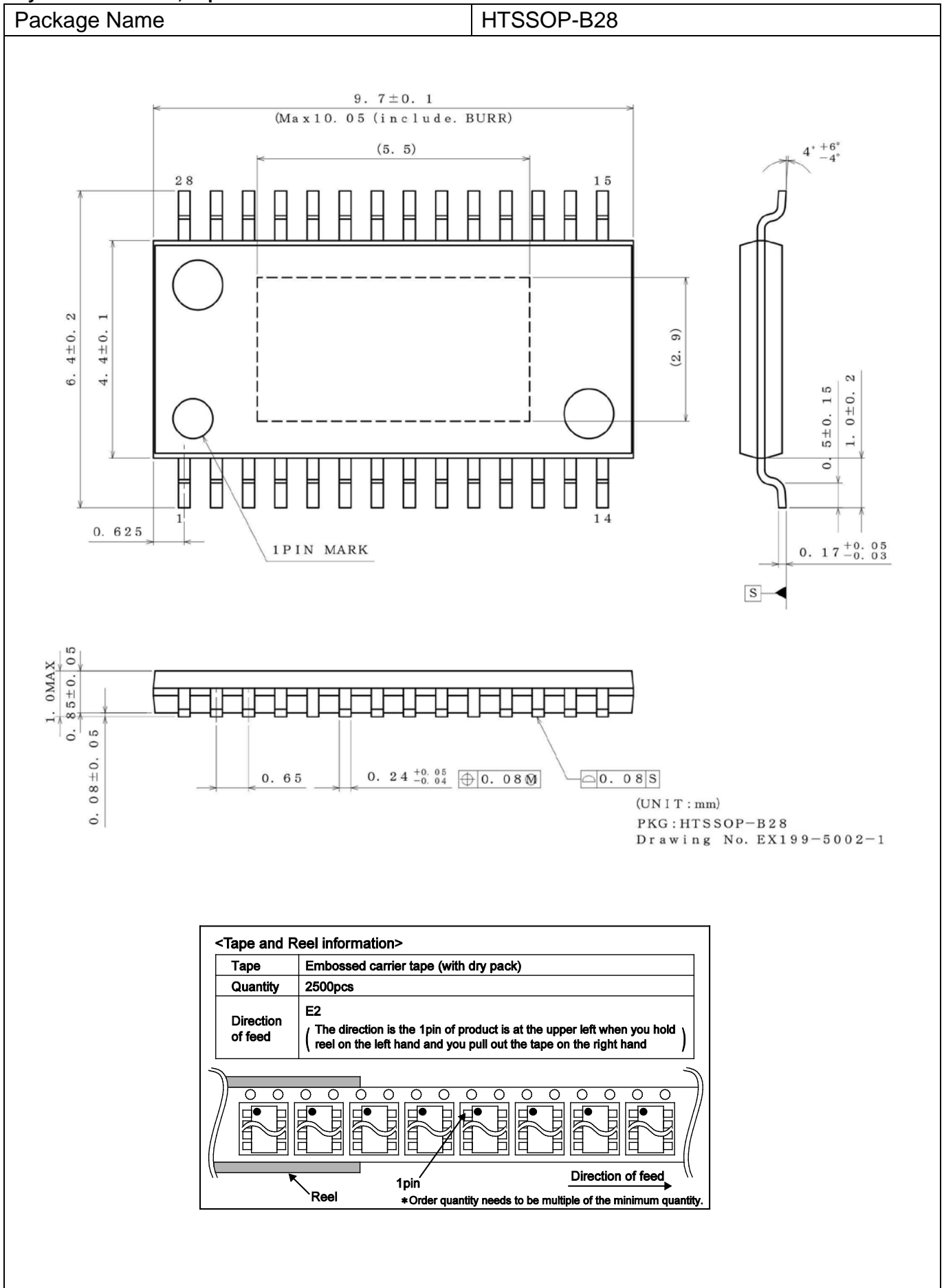

Revision History

Date	Revision	Changes
21.Jun.2016	001	New Release

Notice

Precaution on using ROHM Products

- Our Products are designed and manufactured for application in ordinary electronic equipments (such as AV equipment, OA equipment, telecommunication equipment, home electronic appliances, amusement equipment, etc.). If you intend to use our Products in devices requiring extremely high reliability (such as medical equipment ^(Note 1), transport equipment, traffic equipment, aircraft/spacecraft, nuclear power controllers, fuel controllers, car equipment including car accessories, safety devices, etc.) and whose malfunction or failure may cause loss of human life, bodily injury or serious damage to property ("Specific Applications"), please consult with the ROHM sales representative in advance. Unless otherwise agreed in writing by ROHM in advance, ROHM shall not be in any way responsible or liable for any damages, expenses or losses incurred by you or third parties arising from the use of any ROHM's Products for Specific Applications.

(Note1) Medical Equipment Classification of the Specific Applications

JAPAN	USA	EU	CHINA
CLASS III	CLASS III	CLASS II b	CLASS III
CLASS IV		CLASS III	

- ROHM designs and manufactures its Products subject to strict quality control system. However, semiconductor products can fail or malfunction at a certain rate. Please be sure to implement, at your own responsibilities, adequate safety measures including but not limited to fail-safe design against the physical injury, damage to any property, which a failure or malfunction of our Products may cause. The following are examples of safety measures:
 - Installation of protection circuits or other protective devices to improve system safety
 - Installation of redundant circuits to reduce the impact of single or multiple circuit failure
- Our Products are designed and manufactured for use under standard conditions and not under any special or extraordinary environments or conditions, as exemplified below. Accordingly, ROHM shall not be in any way responsible or liable for any damages, expenses or losses arising from the use of any ROHM's Products under any special or extraordinary environments or conditions. If you intend to use our Products under any special or extraordinary environments or conditions (as exemplified below), your independent verification and confirmation of product performance, reliability, etc. prior to use, must be necessary:
 - Use of our Products in any types of liquid, including water, oils, chemicals, and organic solvents
 - Use of our Products outdoors or in places where the Products are exposed to direct sunlight or dust
 - Use of our Products in places where the Products are exposed to sea wind or corrosive gases, including Cl₂, H₂S, NH₃, SO₂, and NO₂
 - Use of our Products in places where the Products are exposed to static electricity or electromagnetic waves
 - Use of our Products in proximity to heat-producing components, plastic cords, or other flammable items
 - Sealing or coating our Products with resin or other coating materials
 - Use of our Products without cleaning residue of flux (even if you use no-clean type fluxes, cleaning residue of flux is recommended); or Washing our Products by using water or water-soluble cleaning agents for cleaning residue after soldering
 - Use of the Products in places subject to dew condensation
- The Products are not subject to radiation-proof design.
- Please verify and confirm characteristics of the final or mounted products in using the Products.
- In particular, if a transient load (a large amount of load applied in a short period of time, such as pulse. is applied, confirmation of performance characteristics after on-board mounting is strongly recommended. Avoid applying power exceeding normal rated power; exceeding the power rating under steady-state loading condition may negatively affect product performance and reliability.
- De-rate Power Dissipation depending on ambient temperature. When used in sealed area, confirm that it is the use in the range that does not exceed the maximum junction temperature.
- Confirm that operation temperature is within the specified range described in the product specification.
- ROHM shall not be in any way responsible or liable for failure induced under deviant condition from what is defined in this document.

Precaution for Mounting / Circuit board design

- When a highly active halogenous (chlorine, bromine, etc.) flux is used, the residue of flux may negatively affect product performance and reliability.
- In principle, the reflow soldering method must be used on a surface-mount products, the flow soldering method must be used on a through hole mount products. If the flow soldering method is preferred on a surface-mount products, please consult with the ROHM representative in advance.

For details, please refer to ROHM Mounting specification

Precautions Regarding Application Examples and External Circuits

1. If change is made to the constant of an external circuit, please allow a sufficient margin considering variations of the characteristics of the Products and external components, including transient characteristics, as well as static characteristics.
2. You agree that application notes, reference designs, and associated data and information contained in this document are presented only as guidance for Products use. Therefore, in case you use such information, you are solely responsible for it and you must exercise your own independent verification and judgment in the use of such information contained in this document. ROHM shall not be in any way responsible or liable for any damages, expenses or losses incurred by you or third parties arising from the use of such information.

Precaution for Electrostatic

This Product is electrostatic sensitive product, which may be damaged due to electrostatic discharge. Please take proper caution in your manufacturing process and storage so that voltage exceeding the Products maximum rating will not be applied to Products. Please take special care under dry condition (e.g. Grounding of human body / equipment / solder iron, isolation from charged objects, setting of Ionizer, friction prevention and temperature / humidity control).

Precaution for Storage / Transportation

1. Product performance and soldered connections may deteriorate if the Products are stored in the places where:
 - [a] the Products are exposed to sea winds or corrosive gases, including Cl₂, H₂S, NH₃, SO₂, and NO₂
 - [b] the temperature or humidity exceeds those recommended by ROHM
 - [c] the Products are exposed to direct sunshine or condensation
 - [d] the Products are exposed to high Electrostatic
2. Even under ROHM recommended storage condition, solderability of products out of recommended storage time period may be degraded. It is strongly recommended to confirm solderability before using Products of which storage time is exceeding the recommended storage time period.
3. Store / transport cartons in the correct direction, which is indicated on a carton with a symbol. Otherwise bent leads may occur due to excessive stress applied when dropping of a carton.
4. Use Products within the specified time after opening a humidity barrier bag. Baking is required before using Products of which storage time is exceeding the recommended storage time period.

Precaution for Product Label

A two-dimensional barcode printed on ROHM Products label is for ROHM's internal use only.

Precaution for Disposition

When disposing Products please dispose them properly using an authorized industry waste company.

Precaution for Foreign Exchange and Foreign Trade act

Since concerned goods might be fallen under listed items of export control prescribed by Foreign exchange and Foreign trade act, please consult with ROHM in case of export.

Precaution Regarding Intellectual Property Rights

1. All information and data including but not limited to application example contained in this document is for reference only. ROHM does not warrant that foregoing information or data will not infringe any intellectual property rights or any other rights of any third party regarding such information or data.
2. ROHM shall not have any obligations where the claims, actions or demands arising from the combination of the Products with other articles such as components, circuits, systems or external equipment (including software).
3. No license, expressly or implied, is granted hereby under any intellectual property rights or other rights of ROHM or any third parties with respect to the Products or the information contained in this document. Provided, however, that ROHM will not assert its intellectual property rights or other rights against you or your customers to the extent necessary to manufacture or sell products containing the Products, subject to the terms and conditions herein.

Other Precaution

1. This document may not be reprinted or reproduced, in whole or in part, without prior written consent of ROHM.
2. The Products may not be disassembled, converted, modified, reproduced or otherwise changed without prior written consent of ROHM.
3. In no event shall you use in any way whatsoever the Products and the related technical information contained in the Products or this document for any military purposes, including but not limited to, the development of mass-destruction weapons.
4. The proper names of companies or products described in this document are trademarks or registered trademarks of ROHM, its affiliated companies or third parties.

General Precaution

1. Before you use our Products, you are requested to carefully read this document and fully understand its contents. ROHM shall not be in any way responsible or liable for failure, malfunction or accident arising from the use of any ROHM's Products against warning, caution or note contained in this document.
2. All information contained in this document is current as of the issuing date and subject to change without any prior notice. Before purchasing or using ROHM's Products, please confirm the latest information with a ROHM sales representative.
3. The information contained in this document is provided on an "as is" basis and ROHM does not warrant that all information contained in this document is accurate and/or error-free. ROHM shall not be in any way responsible or liable for any damages, expenses or losses incurred by you or third parties resulting from inaccuracy or errors of or concerning such information.

Mouser Electronics

Authorized Distributor

Click to View Pricing, Inventory, Delivery & Lifecycle Information:

[ROHM Semiconductor:](#)

[BD62220AEFV-E2](#)

Данный компонент на территории Российской Федерации

Вы можете приобрести в компании MosChip.

Для оперативного оформления запроса Вам необходимо перейти по данной ссылке:

<http://moschip.ru/get-element>

Вы можете разместить у нас заказ для любого Вашего проекта, будь то серийное производство или разработка единичного прибора.

В нашем ассортименте представлены ведущие мировые производители активных и пассивных электронных компонентов.

Нашей специализацией является поставка электронной компонентной базы двойного назначения, продукции таких производителей как XILINX, Intel (ex.ALTERA), Vicor, Microchip, Texas Instruments, Analog Devices, Mini-Circuits, Amphenol, Glenair.

Сотрудничество с глобальными дистрибьюторами электронных компонентов, предоставляет возможность заказывать и получать с международных складов практически любой перечень компонентов в оптимальные для Вас сроки.

На всех этапах разработки и производства наши партнеры могут получить квалифицированную поддержку опытных инженеров.

Система менеджмента качества компании отвечает требованиям в соответствии с ГОСТ Р ИСО 9001, ГОСТ РВ 0015-002 и ЭС РД 009

Офис по работе с юридическими лицами:

105318, г.Москва, ул.Щербаковская д.3, офис 1107, 1118, ДЦ «Щербаковский»

Телефон: +7 495 668-12-70 (многоканальный)

Факс: +7 495 668-12-70 (доб.304)

E-mail: info@moschip.ru

Skype отдела продаж:

moschip.ru

moschip.ru_4

moschip.ru_6

moschip.ru_9