

Inverted Thru Board Card Edge & Inverted Poke-In Platform Connectors

The Inverted Card Edge and Poke-In Platform Connectors provide 3.0 mm creep and clearance from all other conductive components on FR4 and metal clad printed circuit boards. The 2 position connectors share the same printed circuit board footprint while offering flexibility in providing either a direct power driver board one piece mating solution or a poke-in wire connection to the underside of the LED array boards.

PRODUCT BENEFITS

- The ITB connectors are surface mounted at the same time as other devices on the PCB eliminating secondary processes
- Low profile, space-saving connector designed with and without a cover. The 1.55 mm without cover or 1.90 mm with cover height above the PCB minimizes LED light obstruction.
- Surface mount hold downs provide stability during driver board mating, un-mating and poke-in mating.
- Flat top surface allows for vacuum pick up
- Tape and reel packaging for high speed SMT processing
- Designed with round corners to minimize shadowing
- Both the Inverted Poke-in and Inverted Card Edge Connectors are available with an optional cap that provides for a touch safe design once soldered to the printed circuit board

APPLICATIONS

- Retrofit LED Bulbs
- Track Lighting
- Spot Lights
- Down Lights

MECHANICAL

Inverted Card Edge termination:

- Offered in two versions to accept 1.0 mm or 1.6 mm driver boards
- Polarity keying retention feature options provide additional retention force
- 5 mating cycles

Inverted Poke-In Termination:

- Offered in two versions for poke-in termination of 18 AWG stranded and 18-22 AWG solid and pre-bonded wire or 24-26 AWG solid wire
- Added 1 mm depth dimension to accommodate the wire insulation guide barrels
- Single insertion mating

ELECTRICAL

- Operating Voltage: 400 VAC / VDC
- Operating Current : 3 A, Inverted Card Edge and 18-22 AWG Poke-In
2 A, 24-26 AWG Poke-In
- Operating Temperature: -20 to 130°C
- 3 mm creep and clearance from contacts to MCPCB substrate for non-isolated line voltage power supplies (dielectric withstand voltage)

MATERIALS

- Housing and Cover: 94 V-0 rated high temperature resistant thermoplastic
- Contacts: Tin over nickel plated copper alloy

STANDARDS AND SPECIFICATIONS

- UL 1977
- CSA Std. C22.2 No. 182.3
- Product Specification: **108-32041**
- Application Specification: **108-32054**

te.com/ib



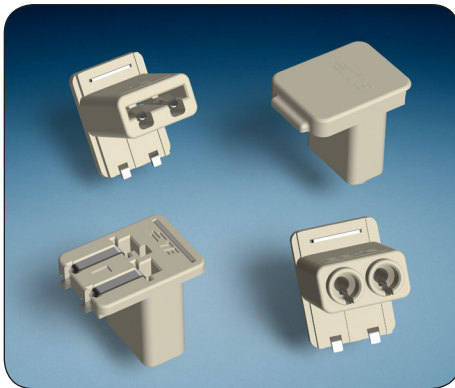

PRODUCT OFFERING

Part Number	Inverted Through Board Connector Style	Board Thickness	Wire Gauge
2213188-1	Card Edge	1.0 mm	
2213188-2	Card Edge	1.6 mm	
2213188-3	Card Edge with Pre-installed Cover	1.0 mm	
2213188-4	Card Edge with Pre-installed Cover	1.6 mm	
2213189-1	Poke-In		18-22 AWG
2213189-2	Poke-In		24-26 AWG
2213189-3	Poke-In with Pre-installed Cover		18-22 AWG
2213189-4	Poke-In with Pre-installed Cover		24-26 AWG

PRODUCT DIMENSIONS

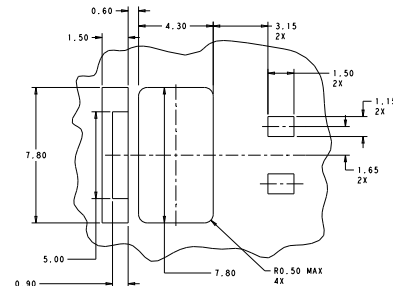
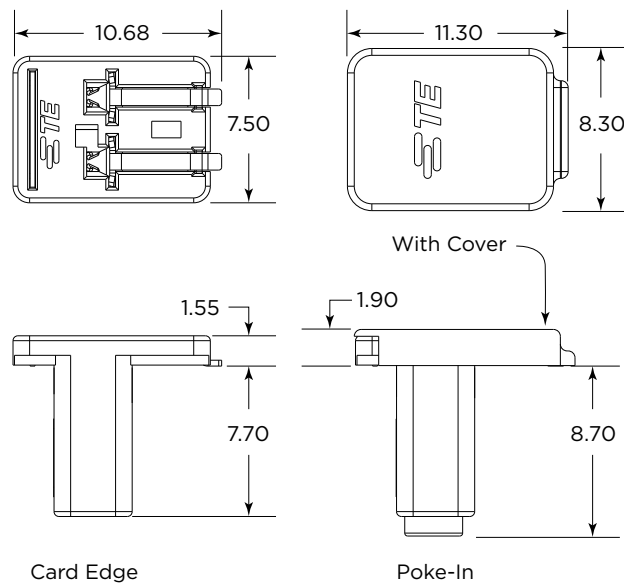

Board Layout

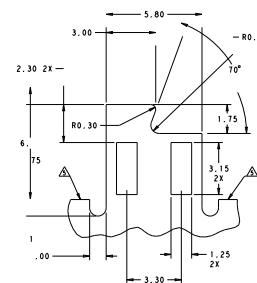

Mating PCB detail

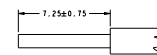

Wire preparation detail

While TE has made every reasonable effort to ensure the accuracy of the information in this brochure, TE does not guarantee that it is error-free, nor does TE make any other representation, warranty or guarantee that the information is accurate, correct, reliable or current. TE reserves the right to make any adjustments to the information contained herein at any time without notice. TE expressly disclaims all implied warranties regarding the information contained herein, including, but not limited to, any implied warranties of merchantability or fitness for a particular purpose. The dimensions in this catalog are for reference purposes only and are subject to change without notice. Specifications are subject to change without notice. Consult TE for the latest dimensions and design specifications.

te.com/ib



Данный компонент на территории Российской Федерации

Вы можете приобрести в компании MosChip.

Для оперативного оформления запроса Вам необходимо перейти по данной ссылке:

<http://moschip.ru/get-element>

Вы можете разместить у нас заказ для любого Вашего проекта, будь то серийное производство или разработка единичного прибора.

В нашем ассортименте представлены ведущие мировые производители активных и пассивных электронных компонентов.

Нашей специализацией является поставка электронной компонентной базы двойного назначения, продукции таких производителей как XILINX, Intel (ex.ALTERA), Vicor, Microchip, Texas Instruments, Analog Devices, Mini-Circuits, Amphenol, Glenair.

Сотрудничество с глобальными дистрибьюторами электронных компонентов, предоставляет возможность заказывать и получать с международных складов практически любой перечень компонентов в оптимальные для Вас сроки.

На всех этапах разработки и производства наши партнеры могут получить квалифицированную поддержку опытных инженеров.

Система менеджмента качества компании отвечает требованиям в соответствии с ГОСТ Р ИСО 9001, ГОСТ РВ 0015-002 и ЭС РД 009

Офис по работе с юридическими лицами:

105318, г.Москва, ул.Щербаковская д.3, офис 1107, 1118, ДЦ «Щербаковский»

Телефон: +7 495 668-12-70 (многоканальный)

Факс: +7 495 668-12-70 (доб.304)

E-mail: info@moschip.ru

Skype отдела продаж:

moschip.ru

moschip.ru_4

moschip.ru_6

moschip.ru_9