

PRODUCT PARTNUMBER
10142333-1XXXXXLF

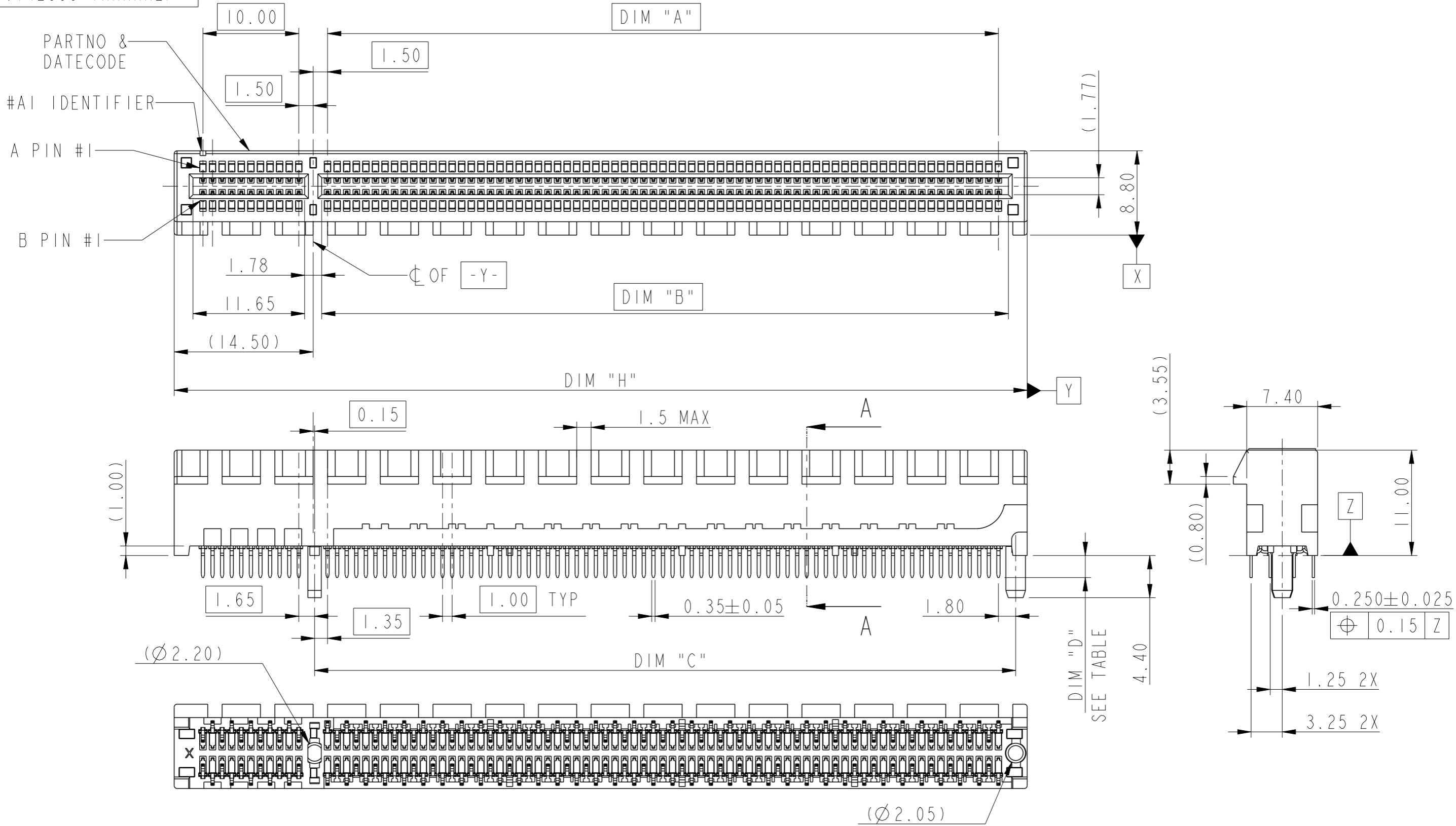

Amphenol FCI
© 2016 AFCI

spec ref	-	dr	Cheong, Matthe	2017/09/18	projection	mm	size	A3	scale	1:1
tolerance std	ISO 406 ISO 1101	eng	Cheong, Matthe	2018/09/11		← →	ecn no	ELX-S-31215-1		
TOLERANCES UNLESS OTHERWISE SPECIFIED		chr	-	-			rel level	Released		
surface	linear	appr	Koon-Poh Tay	2018/09/24	product family	-	rel level	Released		
ISO 1302	angular	Amphenol FCI		PCI EXPRESS 4.0	dwg no	10142333		rev	C	
				TH Type Ass'y	cat. no.	-	Product - Customer Drw	sheet 1 of 4		

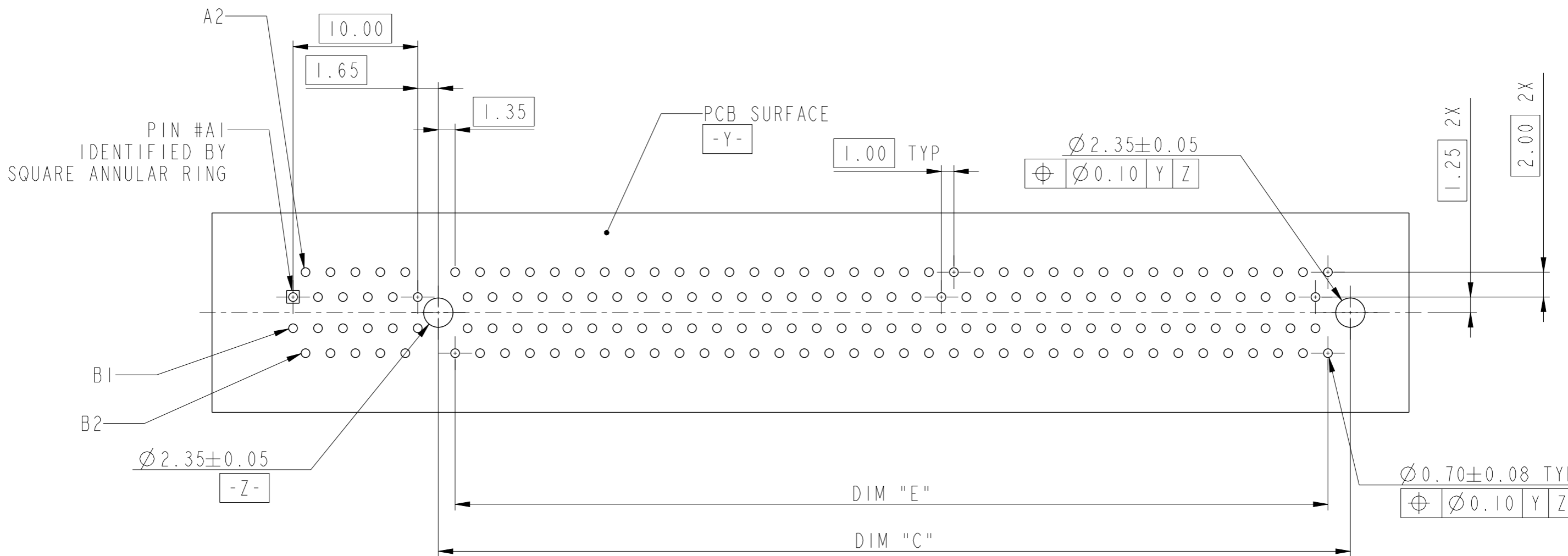

← I/O PANEL DIRECTION
RECOMMENDED PCB LAYOUT

DIMENSIONS					
POSITION	A	B	C	E	H
36	6.00	7.65	9.15	6.00	25.00
64	20.00	21.65	23.15	20.00	39.00
98	37.00	38.65	40.15	37.00	56.00
164	70.00	71.65	73.15	70.00	89.00

spec ref	-	dr	Cheong, Matthe	2017/09/18	projection	mm	size	A3	scale	1:1	
tolerance std	ISO 406 ISO 1101	eng	Cheong, Matthe	2018/09/11			ecn no	ELX-S-31215-1			
TOLERANCES UNLESS OTHERWISE SPECIFIED		chr	-	-			rel level	Released			
surface	ISO 1302	appr	Koon-Poh Tay	2018/09/24	product family	-	dwg no	10142333		rev	C
	linear	0.X	±0.3	Amphenol FCi	PCI EXPRESS 4.0		cat. no. - Product - Customer Drw	sheet 2 of 4			
		0.XX	±0.20		TH Type Ass'y						
	angular	0°	±2°								

CONNECTOR LINK WIDTH	POSITION	N	DIM "G"	DIM "F"	PIN "L"
X1	36	6	8.15	6.00	B17
X4	64	20	22.15	20.00	B31
X8	98	37	39.15	37.00	B48
X16	164	70	72.15	70.00	B81

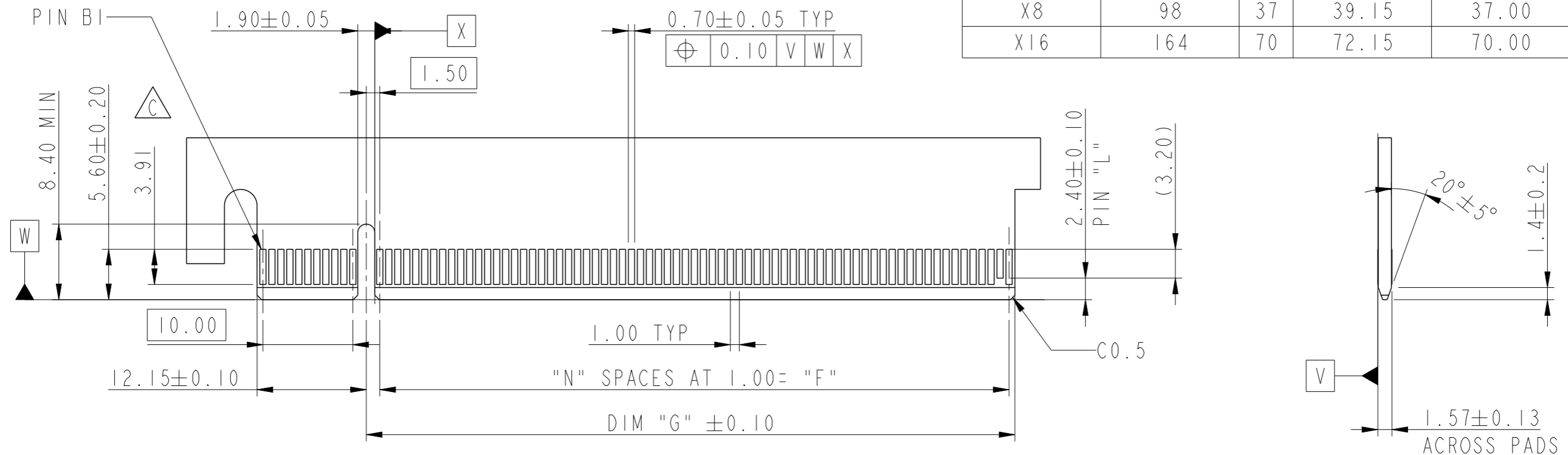

← I/O PANEL DIRECTION
PRIMARY (COMPONENT) SIDE

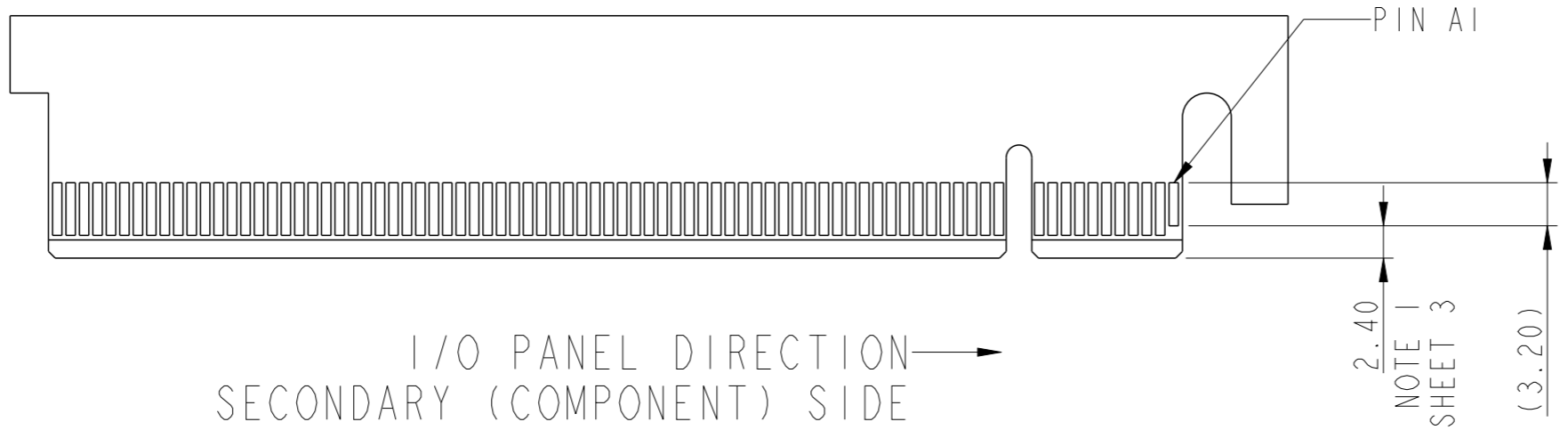

I/O PANEL DIRECTION →
SECONDARY (COMPONENT) SIDE

Amphenol
FCi

© 2016 AFci

spec ref	-	dr	Cheong, Matthe	2017/09/18	projection	mm	size	A3	scale	1:1
tolerance std	ISO 406 ISO 1101	eng	Cheong, Matthe	2018/09/11			ecn no	ELX-S-31215-1		
TOLERANCES UNLESS OTHERWISE SPECIFIED		chr	-	-			rel level	Released		
surface	linear	appr	Koon-Poh Tay	2018/09/24	product family	-	cat. no.	-	Product - Customer Drw	sheet 3 of 4
	angular									
	0.X	±0.3	Amphenol FCI PCI EXPRESS 4.0 TH Type Ass'y		dwg no 10142333		rev C			
	0.XX	±0.20								
	0.XXX	±0.1								
	0°	±2°								

PRODUCT NUMBER CODE

10142333-□□□□□LF

HOUSING COLOUR OPTIONS

1: BLACK

PEGS OPTION

0: PLASTICS PEGS

CONTACT PLATING OPTIONS

0: 50u" Ni UNDERPLATE
 30u" Au CONTACT AREA
 100u" TIN TAIL AREA
 1: 50u" Ni UNDERPLATE
 15u" Au CONTACT AREA
 100u" TIN TAIL AREA

PACKAGING

M: SOFT TRAY (DIM 317.5 x 235 x 18) WITH KAPTON TAPE, 22MM
 Q: HARD TRAY (DIM 323 x 136 x 19) (164 POS)



NO. OF POSITION

0: 36 POS
 1: 64 POS
 2: 98 POS
 3: 164 POS

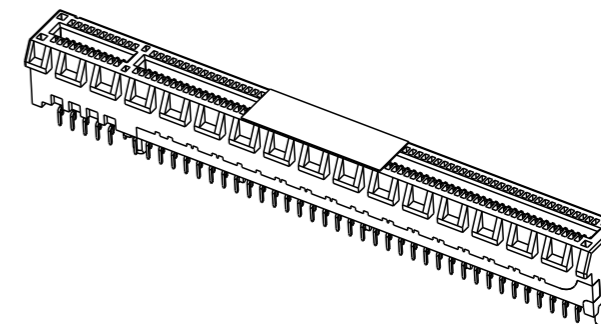

TAIL LENGTH OPTION

	DIM "D"	PCB TICKNESS
0	2.30	1.56
1	3.10	2.36
2	2.54	1.56
3	1.90	1.56

NOTES:

- MATERIAL:
 HOUSING: HIGH PERFORMANCE RESIN, UL94V-0
 CONTACT: COPPER ALLOY
- PLATING:
 SEE TABLE
- PRODUCT SPECIFICATION: GS-12-1406
- PRODUCT MEETS EUROPEAN UNION DIRECTIVES AND OTHER COUNTRIES REGULATIONS AS DESCRIBED IN GS-22-008
- DIMENSION APPLIES TO THE TIP OF TERMINAL.
- DATE CODE B PRINTED ON THIS SURFACE.
 DATE CODE "MMDDYYL", MMDDYY IS ASSEMBLY DATE.
 L IS AFCI PRODUCTION SITE.
 - "M" DENOTES MALAYSIA
- THE HOUSING WITH WITHSTAND EXPOSURE TO 260° PEAK TEMPERATURE FOR 10SECONDS IN A CONVECTION, INFRA-RED OR VAPOR PHASE REFLOW OVEN

POSITION OF KAPTON TAPE

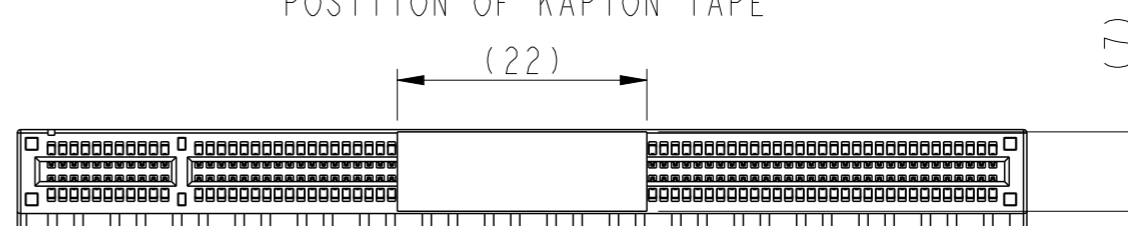

spec ref	-	dr	Cheong, Matthe	2017/09/18	projection	mm	size	A3	scale	1:1
tolerance std	ISO 406 ISO 1101	eng	Cheong, Matthe	2018/09/11			ecn no	ELX-S-31215-1		
surface	linear	chr	-	-			rel level	Released		
		appr	Koon-Poh Tay	2018/09/24	product family	-	rel level	Released		
					Amphenol FCI	PCI EXPRESS 4.0	dwg no	10142333	rev	C
						TH Type Ass'y				
					cat. no.	-	Product - Customer Drw	sheet 4 of 4		

Amphenol FCI

© 2016 AFCI

Данный компонент на территории Российской Федерации

Вы можете приобрести в компании MosChip.

Для оперативного оформления запроса Вам необходимо перейти по данной ссылке:

<http://moschip.ru/get-element>

Вы можете разместить у нас заказ для любого Вашего проекта, будь то серийное производство или разработка единичного прибора.

В нашем ассортименте представлены ведущие мировые производители активных и пассивных электронных компонентов.

Нашей специализацией является поставка электронной компонентной базы двойного назначения, продукции таких производителей как XILINX, Intel (ex.ALTERA), Vicor, Microchip, Texas Instruments, Analog Devices, Mini-Circuits, Amphenol, Glenair.

Сотрудничество с глобальными дистрибьюторами электронных компонентов, предоставляет возможность заказывать и получать с международных складов практически любой перечень компонентов в оптимальные для Вас сроки.

На всех этапах разработки и производства наши партнеры могут получить квалифицированную поддержку опытных инженеров.

Система менеджмента качества компании отвечает требованиям в соответствии с ГОСТ Р ИСО 9001, ГОСТ РВ 0015-002 и ЭС РД 009

Офис по работе с юридическими лицами:

105318, г.Москва, ул.Щербаковская д.3, офис 1107, 1118, ДЦ «Щербаковский»

Телефон: +7 495 668-12-70 (многоканальный)

Факс: +7 495 668-12-70 (доб.304)

E-mail: info@moschip.ru

Skype отдела продаж:

moschip.ru

moschip.ru_4

moschip.ru_6

moschip.ru_9