

FEATURES

- Wide gain range: 0 to 60dB in 3dB steps
- Wide supply range: $\pm 5V$ to $\pm 17V$
- Wide output swing: +27dBu ($\pm 17V$ sup.)
- Wide input swing: +27dBu ($\pm 17V$ sup.)
- Low THD+N: $<0.001\%$ @1kHz, up to 42dB gain
- Integrated differential servo minimizes output offset
- Zero-crossing detector minimizes switching noise
- Daisy Chainable SPI interface
- Four general-purpose digital outputs
- Small 5mm x 5mm QFN24 package

APPLICATIONS

- Digitally controlled microphone preamplifiers
- Digitally-controlled instrumentation amplifiers
- Digitally-controlled differential amplifiers
- Audio mixing consoles
- PC audio breakout boxes
- Audio distribution systems
- Digital audio snakes
- Portable audio recorders

Description

The THAT5173 is a digital gain controller for low-noise, analog, differential, current-feedback audio preamplifiers such as the THAT 1570. When used in conjunction with an appropriate analog gain block, the 5173 supports digitally control gain from 0dB to 60dB in 3dB steps, while preserving low noise and distortion. It operates from $\pm 5V$ to $\pm 17V$ analog supplies, supporting input signal levels as high as +27 dBu (at 0dB gain and $\pm 17V$ supplies) in combination with the 1570 -- without an input pad. The 5173 includes a differential servo and zero-crossing detector to minimize dc offsets and glitches (zipper noise) during gain adjustments.

The 5173 is controlled via an industry standard serial-peripheral interface (SPI) port. Four

General Purpose Outputs (GPOs) can be controlled via this interface. The GPOs may be used to control auxiliary functions such as input selectors, filters, mutes, LEDs, relays, etc.

The 5173 was designed to mate perfectly with the THAT 1570 Differential Audio Preamplifier IC. Together, these combinations provide a high performance solution for digitally-controllable audio preamplifier applications. However, the 5173 may also be used to control a discrete preamplifier.

Fabricated in a high-voltage CMOS process, the 5173 integrates an astonishing amount of circuitry within a very small package. It comes in a small (5x5 mm) 24-pin QFN package, making it suitable for small portable devices.

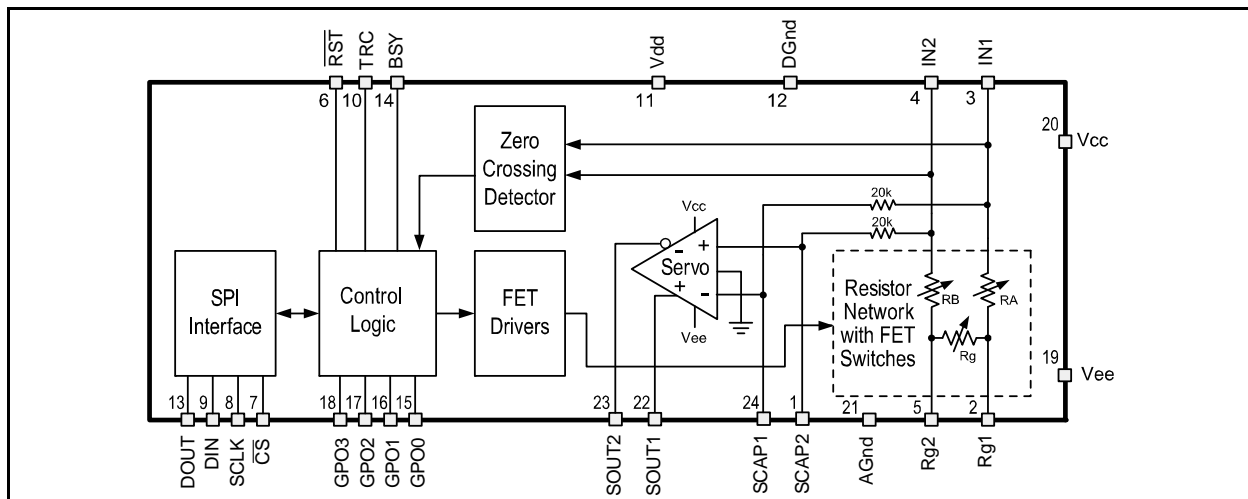

Figure 1. THAT 5173 Block Diagram

Pin Number	Pin Name	Pin Description
1	SCAP2	DC Servo Capacitor Input 2
2	RG1	Attenuator Network Output 1 [Connects to preamplifier feedback 1 (RG1)]
3	IN1	Attenuator Network Input 1 [Connects to preamplifier output 1]
4	IN2	Attenuator Network Input 2 [Connects to preamplifier Output 2]
5	RG2	Attenuator Network Output 2 [Connects to preamplifier feedback Input 2 (RG2)]
6	RST'	Reset Input (Active Low)
7	CS'	Chip Select Input (Active Low)
8	SCLK	Serial Clock Input
9	DIN	Serial Data Input
10	TRC	R/C Timeout or External Clock Input
11	VDD	Logic Positive Power Supply
12	DGND	Logic Ground Reference
13	DOUT	Serial Data Output
14	BSY	Busy Output (Active High)
15	GPO0	General Purpose Output 0
16	GPO1	General Purpose Output 1
17	GPO2	General Purpose Output 2
18	GPO3	General Purpose Output 3
19	VEE	Negative Analog Supply Voltage
20	VCC	Positive Analog Supply Voltage
21	AGND	Analog Ground Reference
22	SOUT1	DC Servo Output 1
23	SOUT2	DC Servo Output 2
24	SCAP1	DC Servo Capacitor Input 1
Thermal Pad	PAD	Connected internally to VEE. Solder to PCB (optionally connect to VEE) for optimal performance.

Table 1. Pin Assignments

SPECIFICATIONS¹

<u>Absolute Maximum Ratings^{2,3}</u>			
Total Analog Supply Voltage ($V_{CC}-V_{EE}$)	36 V	Minimum Analog Voltage at IN1, IN2 (V_{IAMin})	V_{EE}
Positive Analog Supply Voltage ($V_{CC}-A_{GND}$)	18 V	Maximum Digital Input Voltage (V_{IDMax})	$V_{DD} + 0.3 V$
Negative Analog Supply Voltage ($V_{EE}-A_{GND}$)	-18 V	Minimum Digital Input Voltage (V_{IDMin})	$D_{GND} - 0.3 V$
Digital Supply Voltage ($V_{DD}-D_{GND}$)	4.5 V	Storage Temperature Range (T_{STG})	-40 to +125 °C
Analog and Digital Ground Difference ($D_{GND}-A_{GND}$)	±0.3 V	Operating Temperature Range (T_{OP})	-40 to +85 °C
Maximum Analog Voltage at IN1, IN2 (V_{IAMax})	V_{CC}	Junction Temperature (T_{JMAX})	+125 °C
Maximum Current Through V_{DD} , D_{GND}	100 mA		

<u>Electrical Characteristics^{2,4}</u>						
Parameter	Symbol	Conditions	Min	Typ	Max	Units
Power Supply						
Analog Supply Voltage	V_{CC} ; $-V_{EE}$	Referenced to A_{GND}	4.75	—	17	V
Digital Supply Voltage	V_{DD}	Referenced to D_{GND}	3.0	—	3.6	V
Analog Supply Current	I_{CC} ; $-I_{EE}$	No Signal	—	7.6	10	mA
Digital Supply Current	I_{DD}	No Signal	—	2	11	µA
Resistor Ladder Characteristics (DC)						
Gain Range [$-20\log(V_{IN1}-V_{IN2})/(V_{RG1}-V_{RG2})$]		$V_{CC} - 1.6 > V_{IN1} > V_{EE} + 1.6$ $V_{CC} - 1.6 > V_{IN2} > V_{EE} + 1.6$	0	—	60	dB
Gain Step Size		$0dB \leq \text{Gain} \leq 60dB$	—	3	—	dB
Gain Error		All gain settings	-0.5	±0.2	0.5	dB
R_G Range (Resistance from IN ₁ to IN ₂)		All gain settings	13.7	17.1~12.1k	open	Ω
R_A , R_B Range (Resistance from IN ₁ to R_{G1}) (Resistance from IN ₂ to R_{G2})		All gain settings	2.0	2.5~8.6	10.3	kΩ
Servo Amp Characteristics (DC)						
Input Offset Voltage	V_{OS}	Includes bias current effects	-1.75	—	+1.75	mV
Power Supply Rejection Ratio	PSRR	$V_{CC} = -V_{EE}$; ±5V to ±15V	100	115	—	dB
Maximum Output Voltage	V_{OMax}		$V_{CC}-4.5$	—	—	V
Minimum Output Voltage	V_{OMin}		—	—	$V_{EE}+4.5$	V
Maximum Output Current	I_{OMax}		0.70	1.0	—	mA

1. All specifications are subject to change without notice.
2. Unless otherwise noted, $T_A=25^\circ\text{C}$, $V_{CC}=+15\text{V}$, $V_{EE}=-15\text{V}$, $V_{DD}=+3.3\text{V}$
3. Stresses above those listed under "Absolute Maximum Ratings" may cause permanent damage to the device. These are stress ratings only; the functional operation of the device at these or any other conditions above those indicated in the operational sections of this specification is not implied. Exposure to absolute maximum rating conditions for extended periods may affect device reliability.
4. 0 dBu = 0.775 Vrms

Electrical Characteristics (con't) ^{1,3,4}						
Parameter	Symbol	Conditions	Min	Typ	Max	Units
Zero-Crossing Detector Characteristics (DC)						
Zero-Crossing Detector Threshold			—	±12.5	—	mV
ZCD Timeout	t_{ZTO}	$R_T = 22M\Omega$, $C_T = 1\text{ nF}$	—	22	—	ms
ZCD Timing Capacitor	C_T			1	2	nF
ZCD Timing Resistor	R_T		1k	22M	100M	Ω
AC Characteristics						
THD+N (Differential signal applied to $f = 1\text{ kHz}$, Gain = 21 dB, IN_1 , IN_2 , measured at RG_1 , RG_2) $V_{IN1} - V_{IN2} < = +22\text{ dBu}$			—	0.001	—	%
Maximum Signal Voltage at IN_1 , IN_2			—	$V_{CC} - 2.5$	—	V
Minimum Signal Voltage at IN_1 , IN_2			—	$V_{EE} + 2.5$	—	V
Maximum Signal Voltage at RG_1 , RG_2			—	$V_{CC} - 2.5$	—	V
Minimum Signal Voltage at RG_1 , RG_2			—	$V_{EE} + 1.5$	—	V

Electrical Characteristics (con't) ^{1,3,4}					
Parameter	Symbol	Min	Typ	Max	Units
Digital I/O and Switching Characteristics					
High-Level Input Voltage	V_{IH}	$0.7 \times V_{DD}$	–	–	V
Low-Level Input Voltage	V_{IL}	–	–	$0.3 \times V_{DD}$	V
High-Level Output Voltage at $I_o = 4$ mA	V_{OH}	$0.8 \times V_{DD}$	–	–	V
Low-Level Output Voltage at $I_o = -4$ mA	V_{OL}	–	–	0.4	V
Input Leakage Current	I_{in}	–	2	–	μA
Input Capacitance		–	3.5	–	pF
SCLK Frequency	f_{SCLK}	–	–	10	MHz
SCLK Low Time	t_{SCL}	40	–	–	ns
SCLK High Time	t_{SCH}	40	–	–	ns
DIN to SCLK Rising Setup	t_{DSU}	15	–	–	ns
SCLK Rising to DIN Hold Time	t_{DH}	15	–	–	ns
\overline{CS} Enabled to SCLK High	t_{CSCR}	50	–	–	ns
\overline{RST} Release to CS Active	t_{SRS}	100	–	–	ns
\overline{CS} Enabled to DOUT Active	t_{CSDA}	100	–	–	ns
\overline{CS} Release to DOUT Tristate	t_{CSDH}	5	–	20	ns
SCLK Falling to DOUT Valid	t_{CFDO}	–	–	15	ns
\overline{CS} High Time Between Transmissions	t_{CSH}	25	–	–	μs
\overline{CS} Release to SCLK Rising	t_{CSRCR}	100	–	–	ns

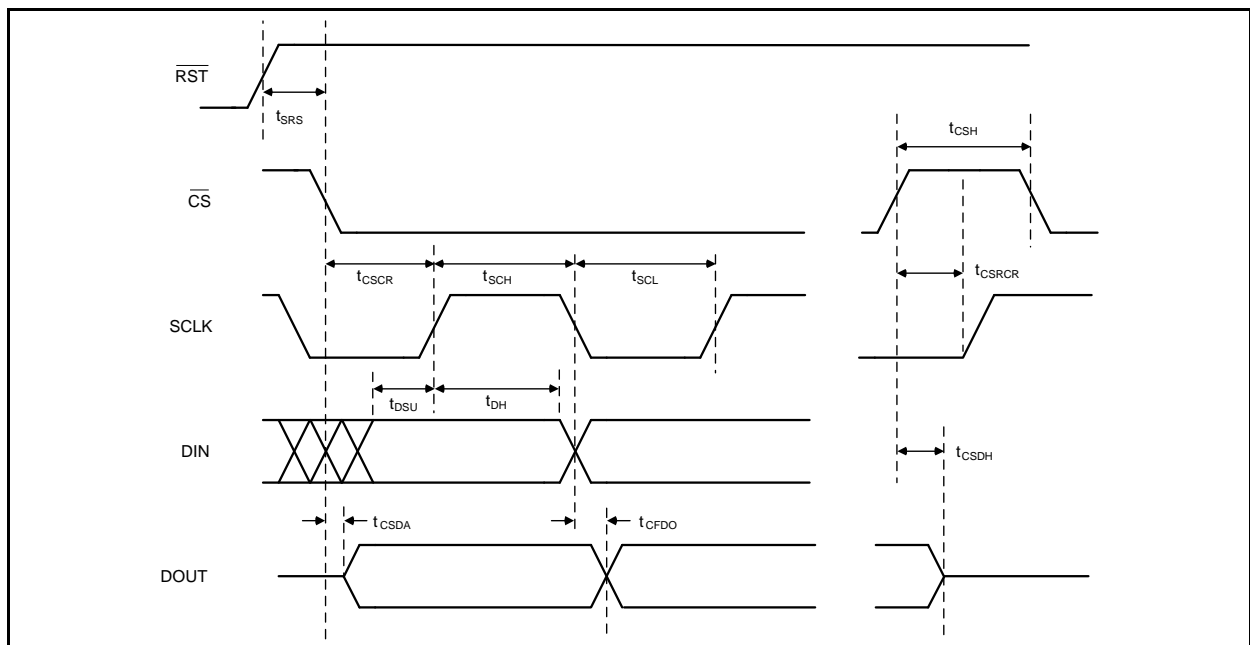

Figure 2. SPI Timing.

Theory of Operation

The THAT 5173 contains a set of precision resistors, switched by a set of CMOS FET switches, configured to create a variable, switched, differential attenuation network. The network's impedances are ideal for controlling gain in low-voltage-noise, current-feed-back instrumentation amplifiers, and are optimized for low source impedance applications.

Using the 5173

The attenuator is intended primarily for use in the feedback loop of differential current-feedback gain stages, such as the THAT 1570. Designed specifically for use in high-performance microphone preamplifiers, THAT's engineers paid careful attention to precision, stability, and control over the resistors and their switches, in order to maintain excellent audio performance over a wide range of gains and signal levels.

Figure 3 shows the analog portion of the 5173 connected to a 1570. Resistors R_A , R_B , and R_G form a differential attenuator ("U-pad"). The amplifier's dif-

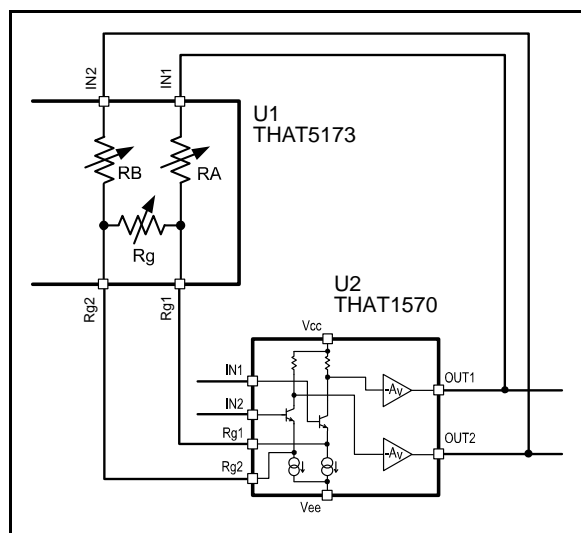

Figure 3. 5173 analog connections to a 1570.

ferential output is applied to R_A and R_B . The output of the attenuator, appearing across R_G , is connected to the inverting differential input of the dual current-feedback amplifiers (the R_{G1} and R_{G2} pins). The voltage divider ratio thus controls the differential gain of the circuit.

The 5173 changes the attenuator settings based on the gain command provided via the SPI control interface. At 0dB gain R_G is an open circuit and $R_A = R_B = 2.5k\Omega$. At +3dB gain, R_G is $\sim 12.12k\Omega$, while $R_A = R_B = \sim 2.5k\Omega$. To achieve other gains, all three resistors are varied by CMOS switches in order to produce 3dB gain steps from 0 to +60dB. At all gains, the impedance levels are chosen to minimize noise and distortion within the circuit as a whole.

Table 2 lists the typical internal attenuator resistor values for each gain setting.

Gain Setting	R_G (Ohms)	R_A, R_B (Ohms)	"Gain" Register
0	Inf	2,500	0
3	12,120.2	2,500	1
6	8,580.5	4,269.9	2
9	3,044.5	2,768	3
12	3,044.5	4,537.9	4
15	3,044.5	7,037.9	5
18	1,080.2	3,750.1	6
21	1,080.2	5,520	7
24	1,080.2	8,020	8
27	383.3	4,098.6	9
30	383.3	5,868.5	10
33	383.3	8,368.5	11
36	136	4,222.2	12
39	136	5,992.1	13
42	136	8,492.1	14
45	48.3	4,266.1	15
48	48.3	6,036	16
51	48.3	8,536	17
54	17.1	4,281.7	18
57	17.1	6,051.6	19
60	17.1	8,551.6	20

Table 2. Internal attenuator resistor values.

Accommodating High Signal Levels

One key objective of the 5173 design was to accommodate full professional-audio signal levels. Accordingly, it is fabricated in a high-voltage CMOS process which allows operation from up to $\pm 17V$ analog power supplies. Along with proprietary (and patent-pending) drive circuitry to the switching FETs, this permits low-distortion operation at signal levels up to over +27dBu in, and +27dBu out. See also DN140 for more discussion and ideas.

Switching Noise

The 5173 includes several features which minimize switching noise during gain changes. Special (patent pending) circuitry slows down the FET gate drive to minimize charge injection. This helps suppress clicks when changing gain. As well, the FET switches are implemented in a balanced fashion so as to maintain equal perturbation to the positive and negative sides of the balanced signal path.

A built-in zero-crossing detector can be used to restrict gain changes to times when the analog signal is very close to zero. The detector monitors the differential signal present between the IN_1 and IN_2 pins

of the 5173. When enabled, it permits gain changes to take place only when the signal is within $\pm 12.5\text{mV}$. A timeout (set by external components R_T and C_T in Figures 8~11) ensures that a gain change will always occur at the expiration of the timeout, in case the signal has not gotten within the voltage window by that time.

The period of a 20Hz waveform is 50ms and thus zero-crossings will occur every 25ms. Accordingly, THAT recommends that the timeout be set to less than or equal to 25ms in order to ensure that gain changes will be made at zero-crossings unless there is some unusual low-frequency signal present. 22mS is the time constant shown in the application schematics. Of course, for special applications, the designer may choose to disable the zero-crossing detection and force immediate gain changes without regard to the signal condition.

With the zero-crossing feature enabled, gain changes are very quiet – barely audible when performed in the absence of program, and all but inaudible with program material present.

Servo and DC Offsets

The 5173 also includes an integrated differential servo amplifier which minimizes dc offset at the output. Practically, it is impossible to ensure that the input offset voltage of the analog gain stage is low enough to maintain low output dc offset at high gains. (For $<10\text{mV}$ output offset, the input offset at $\sim 60\text{dB}$ gain would have to be under $10\mu\text{V}$!) On the other hand, it is not too difficult to make amplifiers with under 1.75mV input offset. By using such an amplifier in feedback around the analog gain stage, it is possible to generate a correction voltage that maintains low output offset from the circuit as a whole.

The integrated differential servo amplifier has under 1.75mV input offset voltage. It requires two large non-polar capacitors in feedback around each half of the amp to form an integrator. The integrator's input is connected to the gain stage's output, and the integrator's output is applied to the gain stage's input. As the loop settles, the gain stage's output will be driven to the input offset voltage of the servo. The loop time constant must be set long enough so as not to interfere with low audio-frequency signals.

The combination of the input coupling capacitors (C_4 and C_5 in Figures 8~11), the bias resistors (R_1 and R_2 – which form a load for C_4 and C_5), and the servo, form a 2nd order highpass filter whose

characteristics change with the gain setting. The Q of this filter is highest at the highest gain setting. (At low gains, the behavior is governed almost entirely by the input coupling network and bias resistors, since the poles split and the one related to the servo moves very low.) Assuming $1.2\text{k}\Omega$ for R_1 and R_2 , and $1.2\text{M}\Omega$ for R_7 and R_8 , we can set the highest Q to be about .77 (for approximately Butterworth response) if we choose C_{12} and C_{13} to be $1/10$ the values of C_4 and C_5 .

We recommend a 1000:1 ratio between servo feed resistors (R_7 and R_8) to the analog gain stage bias resistors (R_1 and R_2) to minimize any noise contribution from the servo amp. Reducing R_7 and R_8 will lower the Q , while increasing them will raise the Q , proportional to the square-root of resistance.

Mathematically, we can express the cutoff frequency, f_o , and the Q as:

$$f_o = \frac{1}{2\pi\sqrt{\frac{1}{G}} R_7 20\text{k}\Omega C_4 C_{13}}, \text{ and}$$

$$Q = \frac{1}{2\pi f_o \frac{1}{G} 20\text{k}\Omega C_{13} K}, \text{ where } G \text{ is the}$$

preamp gain, $K=1+(R_7/R_1)$, $R_1=R_2$, $R_7=R_8$, $C_4=C_5$, $C_{12}=C_{13}$, and the source impedance is less than $1\text{k}\Omega$.

While the servo is effective at minimizing dc offset at the outputs, it does require time to react. When gain is changed, particularly if a sudden large increase in gain is initiated (e.g. 0dB to 60dB), the servo output will not change instantaneously with the gain change. Immediately after the gain increase, the servo will be supplying a dc offset appropriate for the lower gain, and the dc at the output will thus change, on a transient basis, to a higher level. As the servo acquires the new required value, the dc offset will be driven down to under 1.75mV .

To minimize the sonic impact of the dc offset change, THAT recommends that gain be increased slowly by sending many commands to the 5173 that increase gain 3dB (one step) at a time, over a second or more of total time. This replaces the one big change in dc offset with a series of much smaller ones, allowing the servo some time to settle (at least partially) in between each step. Note that the problem is much less audible during stepwise decreases in gain, since the servo's output is not amplified as much at the new (lower) gain as it was at the previous one.

SPI Control Interface

The 5173 provides a daisy chainable serial-peripheral interface (SPI) port for digital control of its internal parameters. The SPI port may be clocked at speeds up to 10MHz, and thus a 16-bit data word can be clocked into the chip in less than 2 us.

The SPI port consists of four signals: Chip Select (CS), Data In (DIN), Data Out (DOUT), and Serial Clock (SCLK). Figure 4 shows a single 5173 device connected to the SPI port of a typical host microcontroller. A command sequence is initiated when CS makes high to low transition. Data is clocked into DIN on rising edges of SCLK, through an internal 16-bit shift register which holds the 5173 configuration, and then out the DOUT pin on falling edges of SCLK. CS makes a low to high transition at the conclusion of a command sequence. The DOUT pin is tristated while CS is high so that multiple devices can be connected to a single SPI MISO port on a host processor.

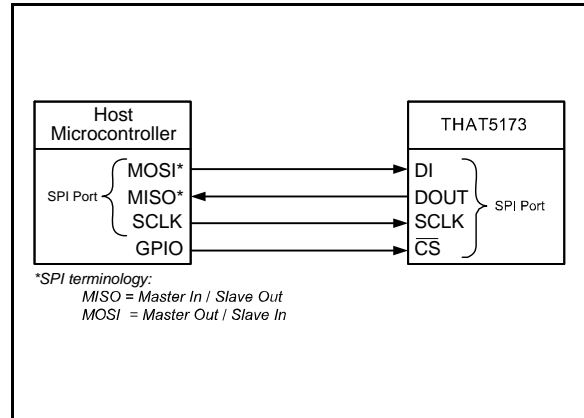

Figure 4. Single 5173 connected to a host microcontroller.

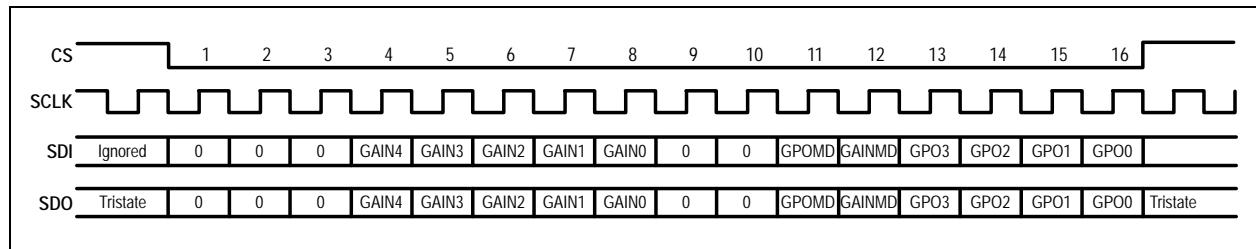

Figure 5. SPI Command Format

Signal	Pin	I/O	Function
$\overline{\text{CS}}$	16	Input	Device chip select input, active low. An SPI transfer begins with a high-to-low CS transition and ends with a low-to-high CS transition. When CS is high, SCLK transitions are ignored.
SCLK	17	Input	SPI serial clock input. An SPI master supplies this clock with frequencies up to 10MHz. Data is clocked into the DIN pin on the rising edge of SCLK. Data is clocked out of DOUT pin on the falling edge of SCLK.
DIN	18	Input	SPI serial data input (Master-Out, Slave-In).
DOUT	19	Output/Tristate	SPI serial data output (Master-In, Slave-Out). DOUT is tristated when CS is high.

Table 3. SPI signals.

Parameters

The 5173 parameters that can be adjusted via SPI are:

- **GAIN (5 bits)**

The GAIN[4:0] bits set the gain of the internal resistor ladder. Note that each increment of 1 in the GAIN value results in a 3dB increment in gain. See Table 4 for gain settings.

Reset default = 00000 (0dB)

- **GPO (4 bits)**

Each of the GPO[3:0] bits controls the state of the respective GPO port as follows:

- 0 = GPO[n] "off" (0V)
- 1 = GPO[n] "on" (3.3V)

Reset default = 0000 (all ports off)

GAIN [4:0]					Decimal Value	5173 Gain
G4	G3	G2	G1	G0		
0	0	0	0	0	0	0
0	0	0	0	1	1	3
0	0	0	1	0	2	6
0	0	0	1	1	3	9
0	0	1	0	0	4	12
0	0	1	0	1	5	15
0	0	1	1	0	6	18
0	0	1	1	1	7	21
0	1	0	0	0	8	24
0	1	0	0	1	9	27
0	1	0	1	0	10	30
0	1	0	1	1	11	33
0	1	1	0	0	12	36
0	1	1	0	1	13	39
0	1	1	1	0	14	42
0	1	1	1	1	15	45
1	0	0	0	0	16	48
1	0	0	0	1	17	51
1	0	0	1	0	18	54
1	0	0	1	1	19	57
1	0	1	0	0	20	60
1	0	1	0	1	21	60
1	0	1	1	0	22	60
:					:	:
1	1	1	1	1	31	60

Table 4. Gain Settings

- **Zero Crossing Detector Enables (2 bits)**

The zero crossing detector can be independently enabled for gain and GPO changes via the GAIN-MODE and GPOMODE config bits respectively. Table 5 shows the bit settings for each of the modes.

Reset default = 00 (ZC off)

GPO MODE	GAIN MODE	
:	:	
:	0	= Immediate GAIN Updates
:	1	= GAIN updates on ZC
:		
0		= Immediate GPO Updates
1		= GPO Updates on ZC

Table 5. Zero Crossing Detector Enables

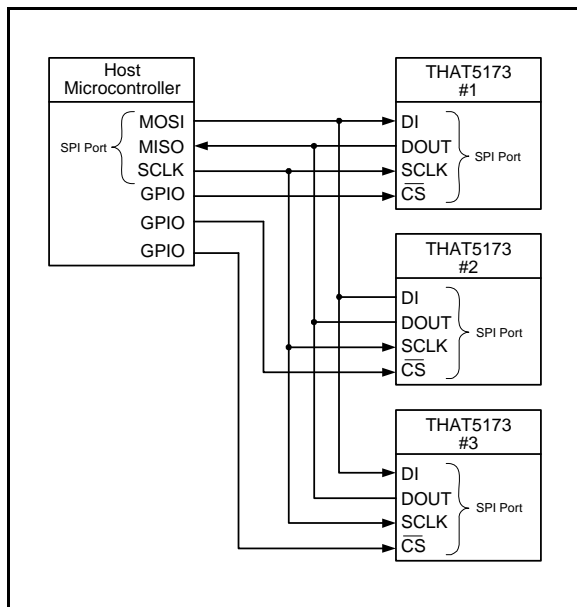

Figure 6. Multiple 5173 ICs connected in parallel to a host microcontroller, with independent chip selects.

Multiple Devices with Separate Chip Selects

The SPI port can be operated with multiple devices by using separate chip selects as shown in Figure 6. The advantage of this method over daisy chaining is that any of the N 5173 devices may be updated with a single 16-bit SPI operation (as opposed to the long $N \times 16$ bit data stream required when N devices are daisy chained). The disadvantage of this method is N different chip selects must be supplied to the individual devices.

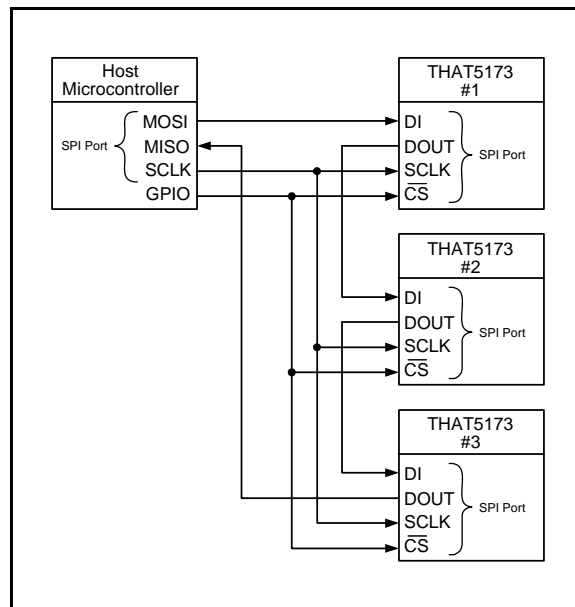

Figure 7. Multiple 5173 ICs connected in a daisy-chained mode to a host microcontroller.

Daisy Chaining

Multiple devices can be daisy-chained by connecting the DOUT of device n to the DIN pin of device $n+1$, as shown in Figure 7. Data is loaded by holding the common CS low for $16 \times N$ SCLK pulses, where N = total number of devices in the daisychain. All devices are simultaneously updated on the rising edge of CS, particularly useful in applications where updates to a large number of channels must be synchronized. Another advantage of this method is one chip select can be shared by all devices, simplifying the digital control circuitry on the PCB. The disadvantage is all N devices must be updated as a group, thereby slowing down the rate of control to each individual device.

Applications

While the 5173 is perfectly suitable for application to virtually any discrete current-feedback differential preamplifier, the applications discussed herein are exclusively based on use with the companion THAT1570 IC. The circuit of Figure 8 shows the most basic application of the 5173 and 1570 to form a complete low-noise digitally-controlled microphone preamplifier.

Gain Ranges in Basic Configurations

The circuit of Figure 8 offers differential gain that varies from 0 to 60dB in 3dB steps. For single-ended analog outputs, the circuit of Figure 8 can be followed by a differential-to-single-ended converter, as shown in Figure 9.

At minimum gain (0dB) and with $\pm 15V$ supply rails, the maximum (differential) input signal level is +26.8dBu, and the maximum (differential) output signal level is +26.6dBu. At maximum gain (+60dB), the maximum input signal level is -33dBu, and the maximum output signal level remains +26.6dBu. All these figures increase by a little over 1dB if the circuit is run from $\pm 17V$ supplies.

When converting to single-ended signals, take care to select a low-noise opamp, and pay attention to the noise generated by the impedances. The component values shown in Figure 9 will largely preserve

the dynamic range of the 1570 and 5173 combination.

For many applications, the output of the microphone preamplifier must drive an analog-to-digital converter. Most high-performance A/D converters have differential inputs, and cannot accept differential signals greater than $\sim +8\text{dBu}$. For such applications, the output of the mic preamp must be attenuated to prevent overload of the A/D converter. The circuit of Figure 10 shows one typical circuit, using a simple resistive attenuator (R_9 through R_{11}). The impedance levels of the attenuator are chosen to minimize their self-generated voltage noise, and to stay within the load limits of the amplifier which drives them. Figure 10 assumes that the maximum differential input to the A/D converter is +8dBu. For higher (or lower) maximum input levels, or for different supply voltages to the 1570 and 5173, scale the attenuator accordingly, keeping its total impedance ($R_9 + R_{10} + R_{11}$) the same. Please note that the noise contribution of the U-pad can compromise the theoretical noise performance of the 1570/5173 combination at minimum gain. Moreover, the non-zero impedance drive to the converter may increase distortion with high-performance converters. The impact of this impedance depends on the ADC.

Note that one drawback of the circuit shown in Figure 10 is that it offers no attenuation of common-signals. The 1570 has unity common-mode gain

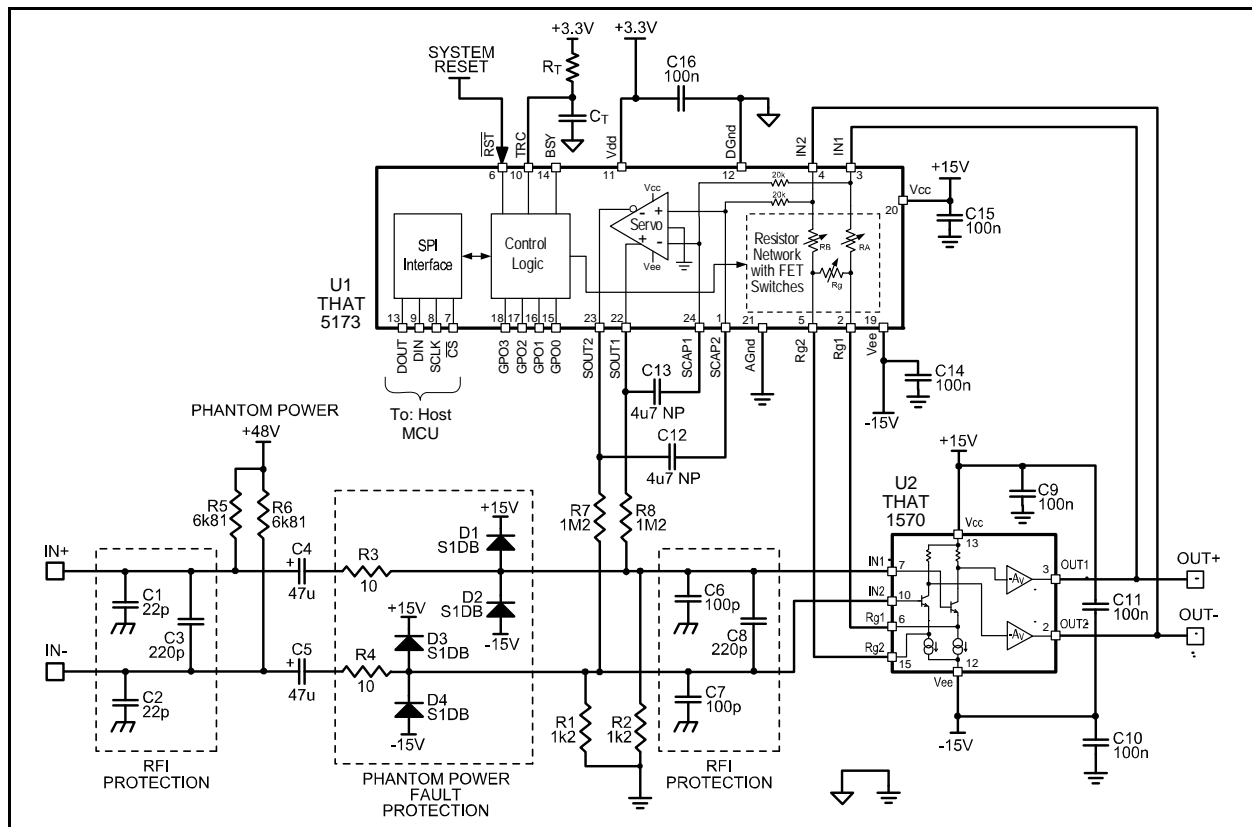

Figure 8. 5173 and 1570 basic application circuit.

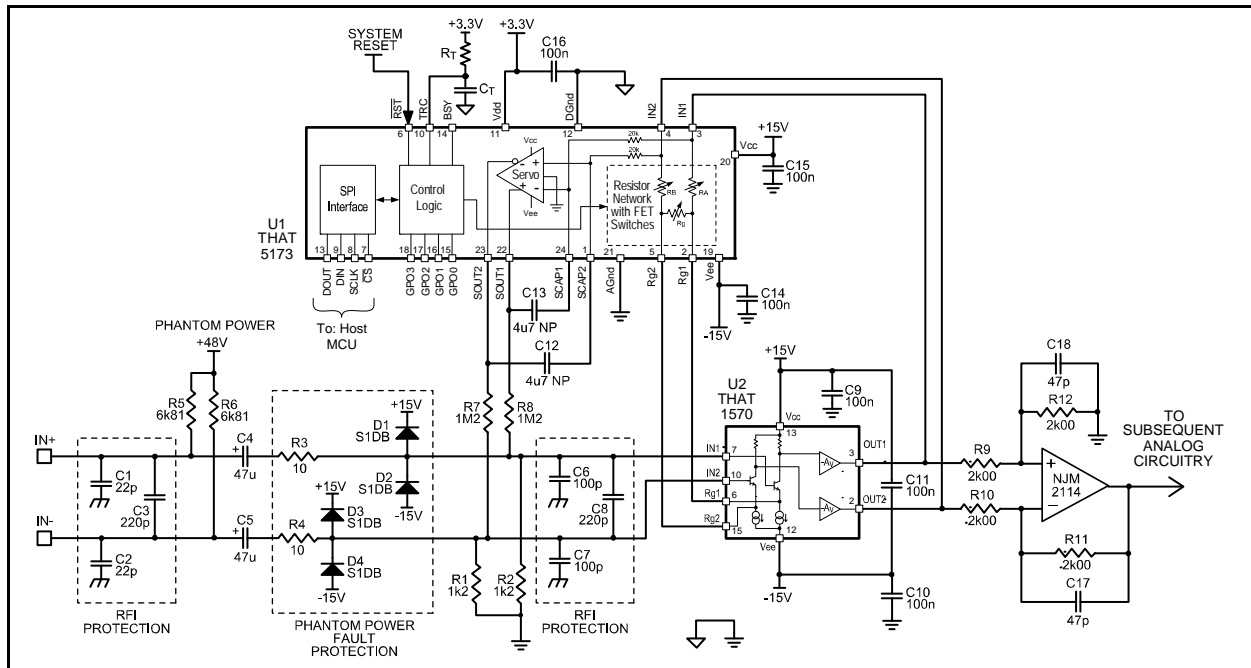

Figure 9. 5173 and 1570 typical application with single-ended output.

regardless of its differential gain. When set to unity gain, the circuit of Figure 8 has 0 dB CMRR. The U-pad attenuator formed by R9~R11 attenuates differential signals but not common-mode signals, so the CMRR of this circuit is actually -9 dB at minimum gain: when the 5173 is set for 0 dB gain, differential input signals are attenuated by 9 dB, but

common-mode signals are passed without any attenuation.

Differential-input A/D converters generally provide high common-mode rejection, so the system CMR including converter may well be acceptable, but consider what happens if a large common-mode signal is present along with a large differential input

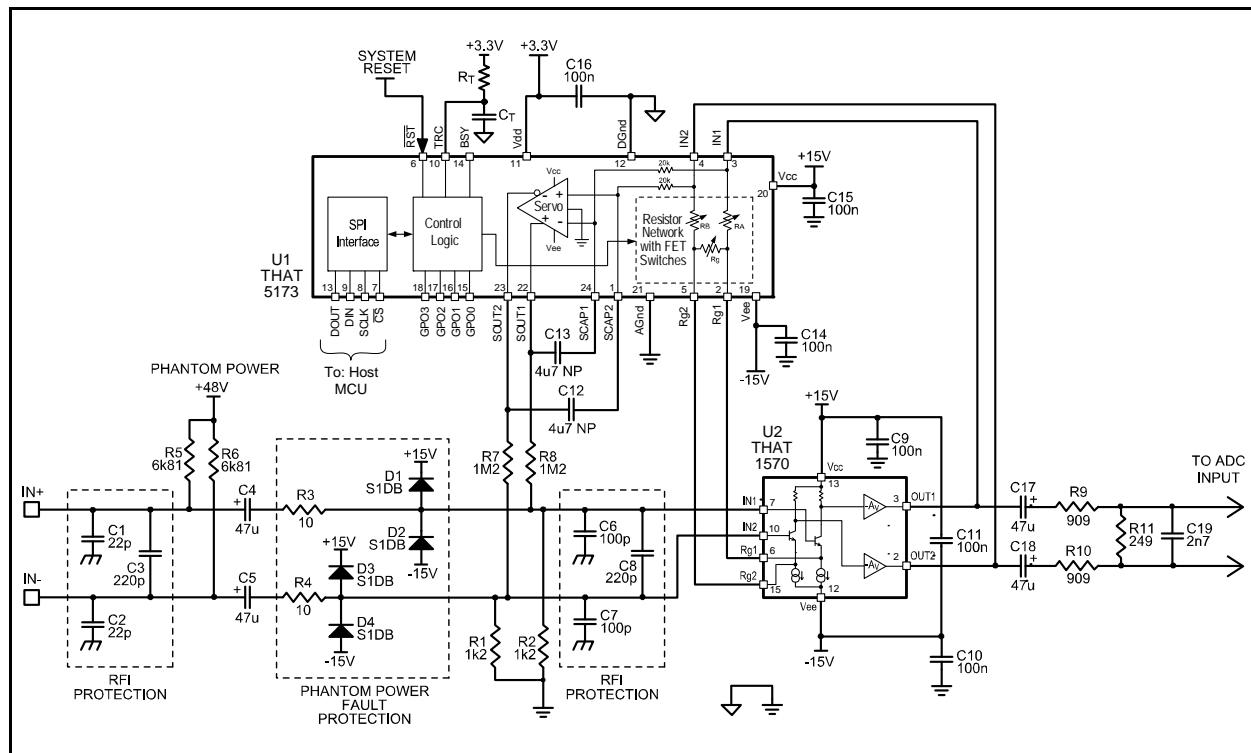

Figure 10. 5173 and 1570 low-cost application for output to an A/D converter.

signal. (This is most likely the case when using the preamp as a line input.) The output of Figure 10 ("To ADC Input") will see that large common-mode input signal, along with a 9 dB attenuated version of the differential input signal. If sufficiently large, the common-mode signal can cause the converter to clip prematurely, modulating the differential audio with the common-mode signal. While this may only occur in extreme use conditions, it may well be of concern.

In such cases, consider the circuit of Figure 11, which removes the common-mode signal (depending on the matching of resistors R9 & R10, R11 & R13, and R14 & R16) before it reaches the A/D converter input. This circuit also provides a low-impedance drive for the converter, recommended by many converter makers for best distortion performance. The novel configuration (after Brit) minimizes the noise contribution of the second (lower) inverter, since it's noise appears in common mode and not differentially at the output.

Note that in this case, at low gains the CMRR of the system will be determined by the matching of resistors R9~R16, with some contribution at high frequencies from the matching of C17 and C18. At high gains, the CMRR of the output stage will be boosted by the gain of the 1570/5173 circuitry that precedes it.

RFI Protection (and Common-Mode Rejection)

The circuits of Fig 8 through 11 include RFI protection in two sections. Small capacitors (C₁ and C₂) are used from the positive and negative signal inputs

to chassis ground, along with a larger capacitor (C₃) across the two inputs. These components should be located as close as possible to the input signal connector, and are intended to prevent RF from entering the chassis of the device.

A second RFI protection network is located close to the amplifier, and is intended to prevent any RF picked up inside the unit from reaching the amplifier input, where it might be rectified and cause audio-band interference. This network consists of a pair of larger capacitors (C₆ and C₇) to ground and one more capacitor (C₈) across the two input lines. If RF is prevented from entering the unit, and none is generated inside the unit, then these capacitors may be omitted or reduced in value.

The design of these networks was arrived at after some consideration for common-mode rejection. Unbalanced capacitance from either input line (IN+ or IN-) to ground can unbalance common-mode signals, converting them to differential signals, which will be amplified along with the desired (differential) signal. The differential amplifier in the above circuits offers gain only to differential signals: common-mode signal gain is always 0dB. Therefore, its common-mode rejection is equal to the differential gain.

So long as common-mode signals are not converted to differential ones, this common-mode rejection will prevail. Because they are relatively small, differences in the values of C₁ and C₂ are less likely to cause imbalance than the larger capacitors at C₆ and C₇. For this reason, we recommend that capacitors C₆ and C₇ should be at least 5% types, in order to ensure matching between their values. Note that C₃

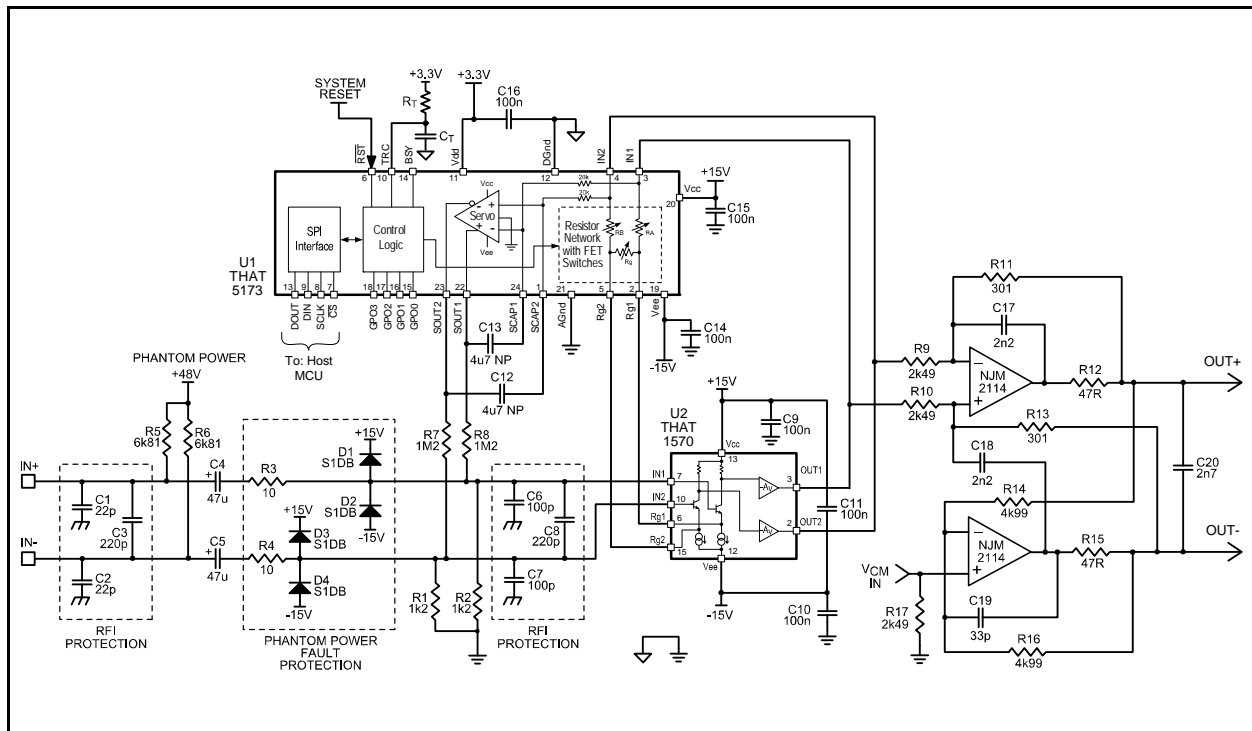

Figure 11. 5173 and 1570 high-performance application for output to an A/D converter.

and C_8 affect only differential signals, and thus do not affect common-mode rejection.

Power Supply Decoupling

Power supply decoupling is required for stability of the 1570, the servo in the 5173, and to minimize digital switching noise from propagating on the power supplies. The V_{CC} and V_{EE} pins should be connected to the same analog supply which powers the analog gain stage, while the V_{DD} pin may be powered in common with other logic circuitry (microprocessors, etc.) in the unit.

THAT recommends one decoupling capacitor (C_{16}) for the digital power supply, placed close to pins 12 (D_{GND}) and 11 (V_{DD}), as these pins connect to the digital output driver bus.

A_{GND} and D_{GND} should be connected together directly under the 5173. Note that the part includes back-to-back diodes limiting the maximum voltage difference between these nodes. If even on a transient basis (e.g., supply spikes) a voltage difference of over 0.5 V exists between A_{GND} and D_{GND} , large currents will flow which may damage the part.

Care should be taken to ensure that the power supply voltages never exceed the absolute maximum ratings even under transient conditions.

As described above (in the Theory section), the integrated differential servo is required for proper operation of the system as shown in the application schematics. By using the servo amplifier in feedback, output offset can be controlled over a wide range of gains.

In order to optimize settling behavior, THAT recommends that C_{12} and C_{13} be approximately one-half the size of C_4 and C_5 . As well, to avoid the servo from contributing noise to the preamplifier, we recommend that the servo's output be divided down by approximately 1000:1 by the combination of R_7/R_1 and R_8/R_2 .

Reset (RST pin)

Asserting the RST pin low forces all internal registers to their default state (see Parameter definitions register definitions in SPI Port section for default values after reset). This pin is typically connected to system reset or to a port on the host microcontroller.

Zero Crossing Detector (and TRC pin)

The integrated zero-crossing detector may be enabled or disabled for the GAIN and GPO

parameters independently (see Table 5). When enabled, it prevents gain and/or GPO changes from occurring until the differential output signal waveform is within ± 12.5 mV of zero.

When the GAINMODE or GPOMODE bits are logic low (Table 5), Gain and GPO updates are made immediately following a rising edge on the /CS pin. When GAINMODE and GPOMODE are logic high, updates are made on the next output signal zero-crossing after a rising edge on the /CS pin.

When no signal is present, the zero-crossing detector may unacceptably delay a gain or GPO change from taking place. A timeout, set by R_T and C_T , is provided to force a change to occur within $R_T C_T$ mS if a zero crossing is not detected. The zero-crossing time-out function operates as follows:

A) C_T is discharged when /CS goes low (the beginning of an SPI command sequence), and is allowed to start charging when /CS goes high (the end of an SPI command sequence).

B) Gain and/or GPOs are updated on the next zero-crossing or when the voltage on the TRC pin charges to $0.7 * V_{DD}$ -- whichever event occurs first.

The recommended time constant for $R_T C_T$ is ~ 22 mS (e.g. $C_T = 1$ nF and $R_T = 22$ M Ω).

The choice between "immediate" vs "zero crossing" mode depends on the application. Immediate mode has the advantage of providing gain updates with short deterministic latency, whereas zero crossing mode has the advantage of minimizing glitches and zipper noise.

Busy (BSY pin)

The BSY pin is asserted high when a gain update or GPO update is pending a zero-crossing. This pin may be monitored by the host microcontroller (e.g. connected to an external interrupt pin) in order to hold off a new gain command until the previous gain command has been executed.

If finer gain steps (e.g. 1dB) are implemented in external processing (typically a DSP) the BUSY signal can be employed to synchronize the external gain changes with those implemented by the 5173 (most importantly, when the interpolated gain "wraps" from maximum to minimum as each 5173 3dB step occurs). Note that latency in A/D conversion must be considered when attempting to synchronize digital with analog gain updates.

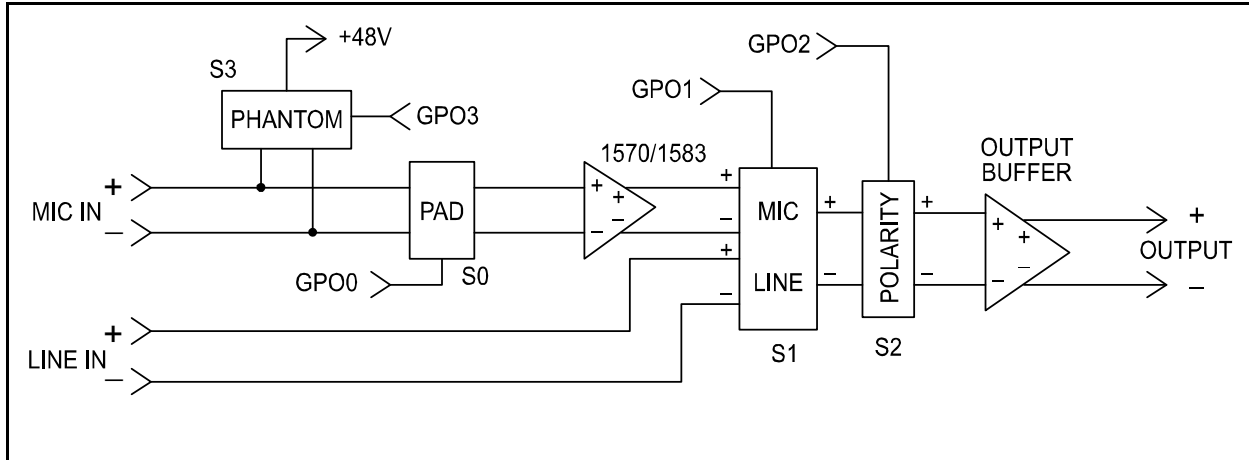

Figure 12. GPO outputs control preamp functions.

Using the GPOs to Control Preamplifier Functions

While the General Purpose Outputs (GPOs) can be used to control any binary state functions, they are primarily intended to control analog functions associated with a preamplifier. Figure 12 is a block diagram showing THAT 5173 GPO outputs

controlling typical preamp functions such as an input pad (GPO0), mic/line switching (GPO1), signal polarity (GPO2), and phantom power (GPO3). There are many ways to control each of these functions, each with its own tradeoffs. See Design Note 140 ("Input and Output Circuits for THAT Preamplifier ICs") for basic circuit ideas using relays.

PCB Layout Information

The 5173 and 1570 are intended to lay out side-by-side, with pins 1 through 4 on the 1570 facing pins 1 through 6 on the 5173. See Figure 13 for a suggested layout.

Designers should take care to minimize capacitance on the Rg pins, and to ensure that power supply lines do not run close and/or parallel to either the input signal lines or the traces and pins connected to the Rg pins. For current feedback amplifiers such as the 1570, stray capacitance from the Rg pins (inverting input) to ground or power planes results in higher gains at high frequencies. As a result, mismatches in the capacitance on these two nodes will degrade common-mode performance at high frequencies.

Additionally, power supply lines, which often carry non-linear (e.g., half-wave rectified) versions of the signal can magnetically and capacitively couple

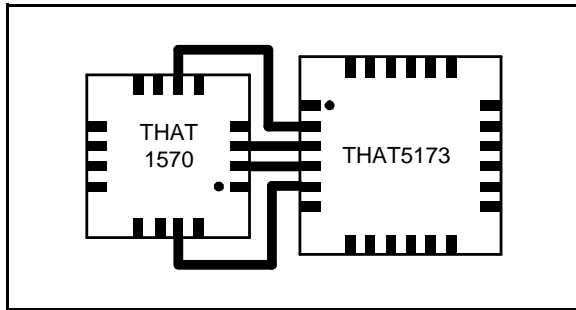

Figure 13. Recommended THAT1570/THAT5173 PCB Layout (mounted on same-side of PCB).

into the input and Rg lines. This can create distortion, particularly at high gains.

Therefore, THAT recommends avoiding ground plane under the IN₁ and IN₂ pins and associated traces. We also recommend a symmetrical PCB layout to match the capacitance on these nodes.

As is customary with QFN packages, we recommend that the metal “slug” on the bottom of the QFN package be soldered to provide physical attachment and improve thermal performance. It may be left unconnected electrically, or connected to V_{EE}.

When laying out the board, we recommend following advice offered by Henry W. Ott in his recent book Electromagnetic Compatibility Engineering, published in August 2009 by Wiley (ISBN: 978-0-470-18930-6). In it, Mr. Ott recommends laying out the digital and analog ground scheme using ground planes as if they were separate planes, but do not actually separate them in the final design. As noted earlier, all bypass capacitors should be located very close to their respective power and ground pins. In particular, for the digital supplies, C16 should connect close to pins 11 and 12.

A useful reference for PCB layout is the demonstration circuit board for the 5173/1570, available from THAT. While the board itself is of course useful to designers, the layout and schematic are published in the data sheet which covers the board, and is available for downloading from THAT’s web site.

Package and Soldering Information

Package Characteristics			
Parameter	Symbol	Conditions	Units
Package Style		See Fig. 14 for dimensions	24 Pin QFN
Thermal Resistance	θ_{JA}	QFN package soldered to board, Thermal pad not soldered to board	70 °C/W
Environmental Regulation Compliance		Complies with January 27, 2003 RoHS requirements	
Soldering Reflow Profile		JEDEC JESD22-A113-D (250 °C)	
Moisture Sensitivity Level	MSL	Above-referenced JEDEC soldering profile	3

The THAT 5173 is available in a 5mm x 5mm 24-pin QFN package. The package dimensions are shown in Figure 14. Pinouts are given in Table 1.

The 5173 is lead free and RoHS compliant. Material Declaration Data Sheets on the parts are available at our web site, www.thatcorp.com or upon request. For ordering information, see Table 6.

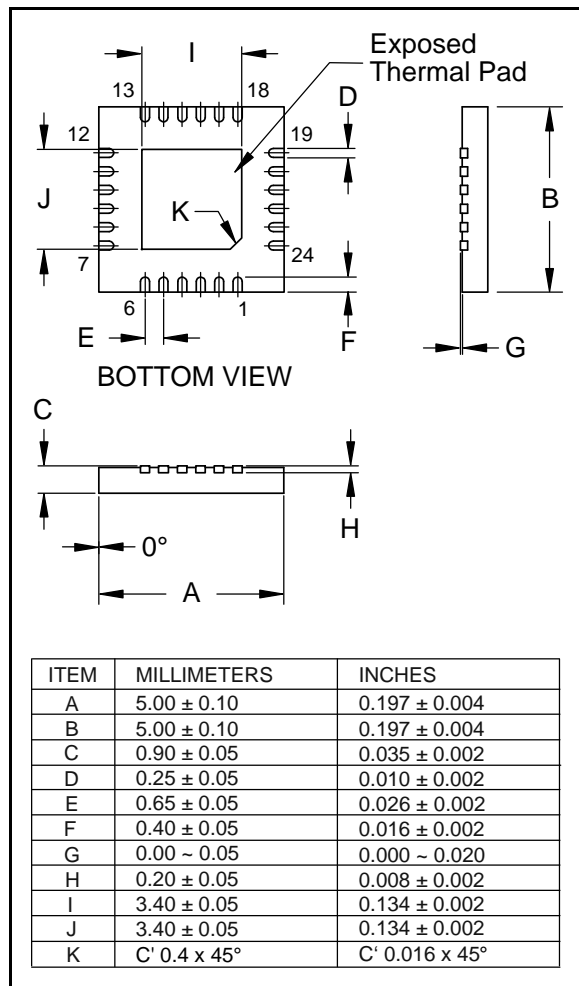

Figure 14. 5 x 5mm QFN-24 Package Dimensions.

Package	Order Number
24 pin QFN	5173N24-U

Table 6. Ordering Information.

Revision History

Revision	ECO	Date	Changes	Page
00	—	March 2012	Release to production	—
01	2737	Nov 2012	Correct typographical errors	4, 16
02	2873	May 2014	Optimized capacitor values in application figures	—
03	2883	July 2014	Corrected error in text regarding value of C12 & C13	7

Notes

Notes

Данный компонент на территории Российской Федерации

Вы можете приобрести в компании MosChip.

Для оперативного оформления запроса Вам необходимо перейти по данной ссылке:

<http://moschip.ru/get-element>

Вы можете разместить у нас заказ для любого Вашего проекта, будь то серийное производство или разработка единичного прибора.

В нашем ассортименте представлены ведущие мировые производители активных и пассивных электронных компонентов.

Нашей специализацией является поставка электронной компонентной базы двойного назначения, продукции таких производителей как XILINX, Intel (ex.ALTERA), Vicor, Microchip, Texas Instruments, Analog Devices, Mini-Circuits, Amphenol, Glenair.

Сотрудничество с глобальными дистрибьюторами электронных компонентов, предоставляет возможность заказывать и получать с международных складов практически любой перечень компонентов в оптимальные для Вас сроки.

На всех этапах разработки и производства наши партнеры могут получить квалифицированную поддержку опытных инженеров.

Система менеджмента качества компании отвечает требованиям в соответствии с ГОСТ Р ИСО 9001, ГОСТ РВ 0015-002 и ЭС РД 009

Офис по работе с юридическими лицами:

105318, г.Москва, ул.Щербаковская д.3, офис 1107, 1118, ДЦ «Щербаковский»

Телефон: +7 495 668-12-70 (многоканальный)

Факс: +7 495 668-12-70 (доб.304)

E-mail: info@moschip.ru

Skype отдела продаж:

moschip.ru

moschip.ru_4

moschip.ru_6

moschip.ru_9