

### 10 Watt

- USB Power Adapter
- Energy Efficiency Level VI
- European CoC Tier 2
- Fixed Mains Connectors
- Universal Input
- Output Voltage 5.0 V
- Class II Construction
- Low Cost



The VEU10 series of wall plug USB adaptors comply with the very latest energy efficiency VI standards with high active mode efficiency and extremely low no load power consumption.

#### Dimensions:

##### VEU (Case Only):

- US: 1.45 x 0.86 x 2.0" (37.0 x 22.0 x 50.8 mm)
- EU: 1.45 x 0.86 x 2.2" (37.0 x 22.0 x 56.5 mm)
- UK: 1.92 x 1.68 x 2.0" (48.8 x 42.8 x 50.8 mm)

### Models & Ratings

Output Power	Output Voltage	Output Current	Total Regulation	Input Connector	Model Number <sup>(2)</sup>
10 W	5.0V	2100 mA	5%	UK	VEU10US050-UK
	5.0V	2100 mA	5%	US	VEU10US050-US
	5.0V	2100 mA	5%	EU	VEU10US050-EU

### Notes

1. Total regulation includes initial set accuracy, line and load regulation.
2. For white case version add suffix '-W' e.g. VEU10US050-US-W. MOQ applies, contact sales for details.

### Input

Characteristic	Minimum	Typical	Maximum	Units	Notes & Conditions
Input Voltage	90		264	VAC	
Input Frequency	47		63	Hz	
Input Current			0.3	A	100 VAC
Inrush Current			60	A	240 VAC, cold start at 25 °C
Power Factor					EN61000-3-2, class A
No Load Input Power			<0.075	W	
Input Protection	Internal T1.0A/250 VAC fuse				

### Output

Characteristic	Minimum	Typical	Maximum	Units	Notes & Conditions
Minimum Load	0			A	No minimum load required
Start Up Delay			4	s	
Start Up Rise Time		30		ms	
Hold Up Time		11		ms	Full load and 115 VAC
Total Regulation			5	%	See Models and Ratings table
Transient Response			4	% deviation	Recoverly within <1% within 500 µs for a 50% step load change at 0.15 A/µs
Ripple & Noise			200	mV pk-pk	Measured with 20 MHz bandwidth and 47 µF electrolytic in parallel with 0.1 µF ceramic capacitor
Short Circuit Protection					Continuous, trip and restart (hiccup mode) with auto recoverly
Temperature Coefficient			0.05	%/°C	

### General

Characteristic	Minimum	Typical	Maximum	Units	Notes & Conditions
Energy Efficiency					Level VI and CoC Tier 2
Isolation		3000		VAC	Input to Output
Switching Frequency	24		70	kHz	Variable
Mean Time Between Failure	100			kHrs	MIL-HDBK-217F at 25 °C GB
Weight		0.11 (50)		lb (g)	For -UK version

### Environmental

Characteristic	Minimum	Typical	Maximum	Units	Notes & Conditions
Operating Temperature	0		+60	°C	Derate from 100% load at 40 °C to 50% load at 60 °C
Storage Temperature	-40		+85	°C	
Operating Humidity	5		95	%	RH, non-condensing
Cooling					Natural convection
Shock					1 m drop onto concrete on each of 6 axes
Vibration	10		300	Hz	2 g 15 mins/sweep, 60 mins for each of 3 axes

### EMC: Emissions

Phenomenon	Standard	Test Level	Notes & Conditions
Conducted	EN55032	Level B	
Radiated	EN55032	Level B	
Harmonic Current	EN61000-3-2	Class A	
Voltage Flicker	EN61000-3-3		

### EMC: Immunity

Phenomenon	Standard	Test Level	Criteria	Notes & Conditions
ESD Immunity	EN61000-4-2	2,3	A	±4 kV contact, ±8 kV air
Radiated Immunity	EN61000-4-3	3 V/m	A	
EFT/Burst	EN61000-4-4	Level 2	A	
Surge	EN61000-4-5	Level 2	A	
Conducted Immunity	EN61000-4-6	3 V	A	
Magnetic Fields	EN61000-4-8	1 A/m	A	
Dips and Interruptions	EN55024 100% 10 ms, 30% 500 ms, 100% 5000 ms, Perf Criteria A, A, B			

### Safety Approvals

Phenomenon	Standard
CB Report	IEC60950-1
UL	UL/cUL60950-1, approved as limited power source (LPS)
TUV	EN60950-1
CCC	China Compulsory Certification, GB4943
AU/NZ	AU/NZ 60950.1

### Mechanical Details

#### VEU10US050-UK

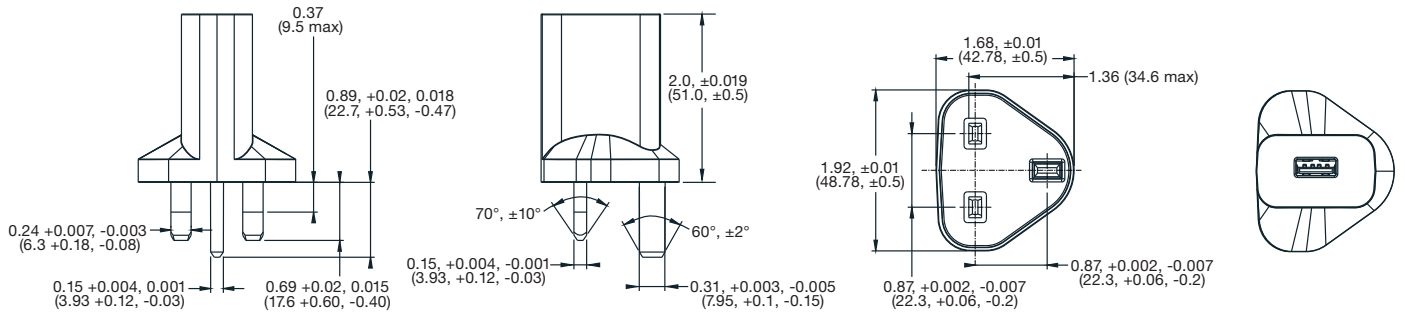

#### VEU10US050-EU

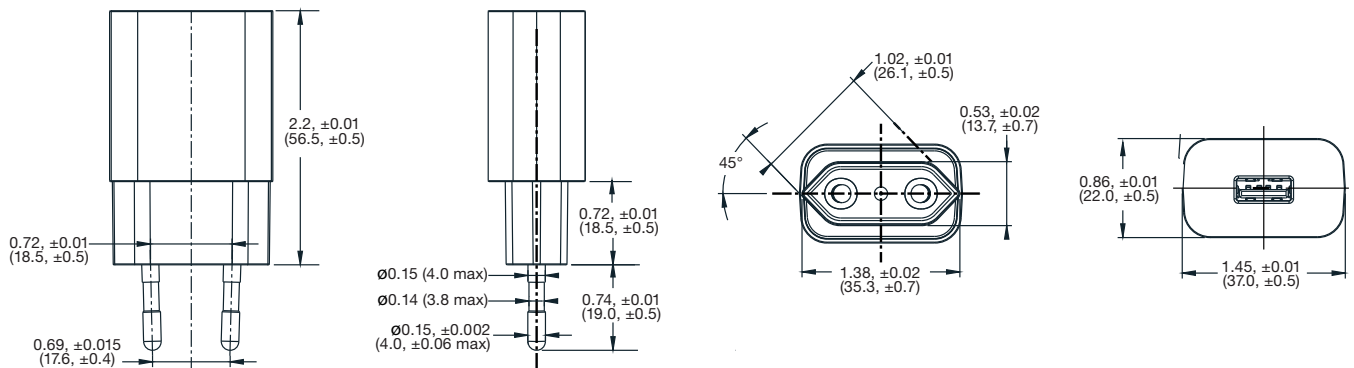

#### VEU10US050-US

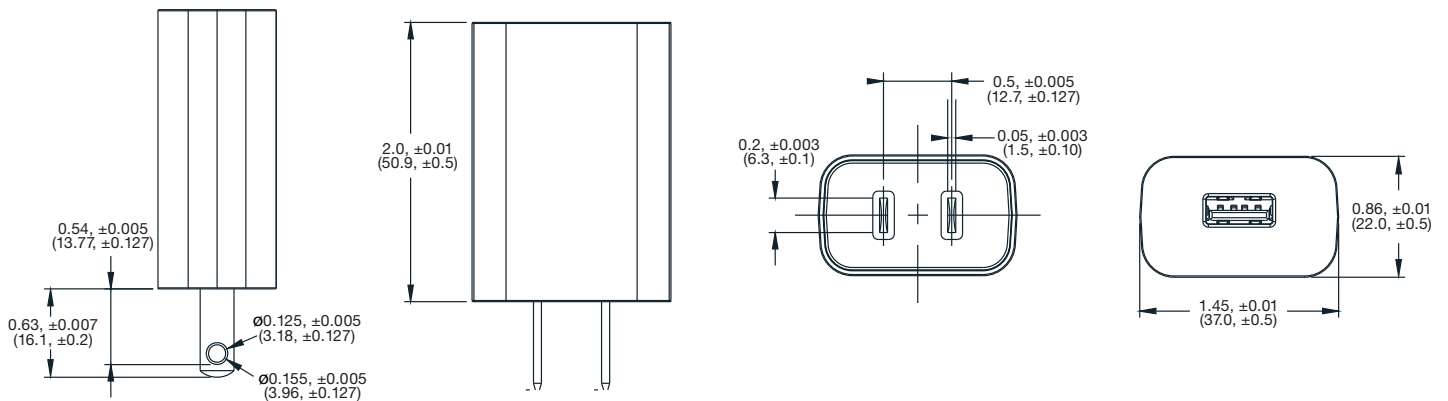

## Данный компонент на территории Российской Федерации

### Вы можете приобрести в компании MosChip.

Для оперативного оформления запроса Вам необходимо перейти по данной ссылке:

<http://moschip.ru/get-element>

Вы можете разместить у нас заказ для любого Вашего проекта, будь то серийное производство или разработка единичного прибора.

В нашем ассортименте представлены ведущие мировые производители активных и пассивных электронных компонентов.

Нашей специализацией является поставка электронной компонентной базы двойного назначения, продукции таких производителей как XILINX, Intel (ex.ALTERA), Vicor, Microchip, Texas Instruments, Analog Devices, Mini-Circuits, Amphenol, Glenair.

Сотрудничество с глобальными дистрибьюторами электронных компонентов, предоставляет возможность заказывать и получать с международных складов практически любой перечень компонентов в оптимальные для Вас сроки.

На всех этапах разработки и производства наши партнеры могут получить квалифицированную поддержку опытных инженеров.

Система менеджмента качества компании отвечает требованиям в соответствии с ГОСТ Р ИСО 9001, ГОСТ РВ 0015-002 и ЭС РД 009

### Офис по работе с юридическими лицами:

105318, г.Москва, ул.Щербаковская д.3, офис 1107, 1118, ДЦ «Щербаковский»

Телефон: +7 495 668-12-70 (многоканальный)

Факс: +7 495 668-12-70 (доб.304)

E-mail: [info@moschip.ru](mailto:info@moschip.ru)

Skype отдела продаж:

moschip.ru

moschip.ru\_4

moschip.ru\_6

moschip.ru\_9