

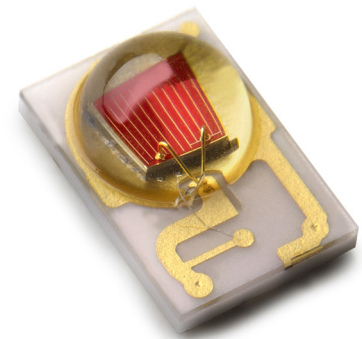

# LUXEON Rebel, Red-Orange & Amber

## High flux solution for signaling applications

Automotive grade LUXEON Rebel LEDs are designed and tested to meet and exceed expectations for reliability, performance and lifetime in all vehicle applications. LUXEON Rebel Red-Orange and Amber LEDs are particularly advantageous for both efficient light guide coupling and automotive tail applications, and for high brightness automotive applications. Lumileds automotive color binning structure meets both SAE and ECE color specifications. LUXEON Rebel meets both SAE and ECE color specifications and provides finer granularity than existing systems.



### FEATURES AND BENEFITS

- High flux output provides flexibility in styling and optical design
- Low forward voltage results in higher efficacy and lower solution costs
- Electrically isolated thermal pad to reduce thermal management engineering costs
- AEC-Q101C qualified and PPAP documentation available

### PRIMARY APPLICATIONS

- Rear Fog
- Side Marker
- Stop/Tail
- Turn

# Table of Contents

General Information .....	2
Part Number Nomenclature .....	2
LED Lifetime Characteristics .....	2
Environmental Compliance .....	2
Flux Characteristics .....	3
Optical Characteristics .....	3
Electrical Characteristics .....	4
Absolute Maximum Ratings .....	5
Absolute Minimum Ratings .....	5
JEDEC Moisture Sensitivity .....	5
Reflow Soldering Characteristics .....	6
Mechanical Dimensions .....	7
Pad Configuration .....	8
Wavelength Characteristics .....	8
Typical Light Output Characteristics over Temperature .....	9
Typical Forward Voltage Characteristics .....	10
Typical Relative Luminous Flux .....	11
Current Derating Curves .....	12
Typical Radiation Patterns .....	13
Emitter Pocket Tape Packaging .....	14
Emitter Reel Packaging .....	15
Automotive Product Binning and Labeling .....	16
Color Bin Structure .....	17
Forward Voltage Bins .....	17

# General Information

## Part Number Nomenclature

LUXEON Rebel is tested and binned at 350mA.

The part number designation is explained as follows:

L X M A - **A B C D** - **E F G H**

Where:

- A — designates radiation pattern (value P for Lambertian)
- B — designates color variant (L for amber, H for red-orange)
- C — designates color variant (0 for automotive amber and red-orange)
- D — designates technology (1 for automotive amber and red-orange standard flux direct color; 2 for red-orange high flux direct color)
- E — reserved for future product offerings
- FGH — minimum luminous flux (lm) performance

Products tested and binned at 350mA follow the part numbering scheme:

L X M A - P x 0 x - x x x x

## LED Lifetime Characteristics

Lifetime for solid state lighting devices (LEDs) is defined in terms of lumen maintenance - the percentage of initial light output remaining after a specified period of time - and light output failures such as shorts. These two degradation modes are both considered in Lumileds LED lifetime assessment.

LED lifetime performance is based on independent test data, Lumileds historical data from tests run on similar material systems, and internal product reliability testing.

Please contact your Lumileds Sales Representative for LUXEON LED product lifetime assessment for your operational conditions.

## Environmental Compliance

Lumileds is committed to providing environmentally friendly products to the solid-state lighting market. The LUXEON Rebel is compliant to the European Union directives on the restriction of hazardous substances in electronic equipment, namely the REACH, ELV, and RoHS directives. Lumileds will not intentionally add the following restricted materials to the LUXEON Rebel: lead, mercury, cadmium, hexavalent chromium, polybrominated biphenyls (PBB) or polybrominated diphenyl ethers (PBDE).

# Flux Characteristics

## Flux Characteristics for LUXEON Rebel, Junction Temperature, $T_j = 25^\circ\text{C}$ [4]

Table 1.

Performance at Binning Current				Typical Performance at Maximum Current	
Color	Part Number [5]	Minimum Luminous Flux (lm) $\Phi_V$ [1] [3]	Binning Current (mA)	Typical Luminous Flux (lm) $\Phi_V$ [2] [3]	Maximum Current (mA)
Red-Orange	LXMA-PH01-0040	40	350	75	700
	LXMA-PH01-0050	50	350	85	700
	LXMA-PH02-0060	60	350	122	700
	LXMA-PH02-0070	70	350	134	700
Amber	LXMA-PL01-0023	23.5	350	45	700
	LXMA-PL01-0030	30	350	60	700
	LXMA-PL01-0040	40	350	70	700

Note for Table 1:

1. Minimum luminous flux performance guaranteed within published operating conditions. Lumileds maintains a tolerance of  $\pm 6.5\%$  on flux measurements.
2. Typical luminous flux or radiometric power performance when device is operated within published operating conditions.
3. LUXEON Rebel products with even higher luminous flux and radiometric power levels will become available in the future. Please consult Lumileds for more information.
4. Junction Temperature is estimated based on instant measurement at thermal pad temperature of  $25^\circ\text{C}$ .
5. Please contact Lumileds for information on custom part numbers.

# Optical Characteristics

## Lambertian LUXEON Rebel at Test Current [1], Junction Temperature, $T_j = 25^\circ\text{C}$ [8]

Table 2.

Color	Dominant Wavelength (nm)			Typical Spectral Half-width [3] (nm) $\Delta\lambda_{1/2}$	Typical Temperature Coefficient of Dominant Wavelength (nm/ $^\circ\text{C}$ ) $\Delta\lambda_D / \Delta T_j$	Typical Total Included Angle [4] (degrees) $\theta_{0.90V}$	Typical Viewing Angle [5] (degrees) $2\theta_{1/2}$
	Minimum	Typical	Maximum				
Red-Orange	613.0 nm	617.0 nm	620.0 nm	20	0.08	160	125
Amber	587.0 nm	590.0 nm	592.0 nm	14	0.10	160	125

Notes for Table 2:

1. LUXEON Rebel is tested and binned at 350mA.
2. Dominant wavelength is derived from the CIE 1931 Chromaticity diagram and represents the perceived color. Lumileds maintains a tolerance of  $\pm 0.5$  nm for dominant wavelength measurements.
3. Spectral width at 1/2 of the peak intensity.
4. Total angle at which 90% of total luminous flux is captured.
5. Viewing angle is the off axis angle from lamp centerline where the luminous intensity is 1/2 of the peak value.
6. Junction temperature is estimated based on instant measurement at thermal pad temperature of  $25^\circ\text{C}$ .

# Electrical Characteristics

## Electrical Characteristics at 350mA for LUXEON Rebel, Junction Temperature, $T_j = 25^\circ\text{C}$

Table 3.

Part Number	Forward Voltage $V_f$ <sup>[1]</sup> (V)			Typical Dynamic Resistance <sup>[4]</sup> ( $\Omega$ ) $R_D$	Typical Temperature Coefficient of Forward Voltage <sup>[2]</sup> (mV/ $^\circ\text{C}$ ) $\Delta V_F / \Delta T_J$	Typical Thermal Resistance Junction to Thermal Pad <sup>[3]</sup> ( $^\circ\text{C}/\text{W}$ ) $R_{\theta_{J-C}}$
	Minimum	Typical	Maximum			
LXMA-PH01-0040	2.31	2.9	3.51	1.5	-2.0 to -4.0	12
LXMA-PH01-0050	2.31	2.9	3.51	1.5	-2.0 to -4.0	12
LXMA-PH02-0060	1.80	2.10	2.80	0.57	-2.0 to -4.0	8
LXMA-PH02-0070	1.80	2.10	2.80	0.57	-2.0 to -4.0	8
LXMA-PL01-0023	2.31	2.9	3.51	1.3	-2.0 to -4.0	12
LXMA-PL01-0030	2.31	2.9	3.51	1.3	-2.0 to -4.0	12
LXMA-PL01-0040	2.31	2.9	3.51	1.3	-2.0 to -4.0	12

Notes for Table 3:

1. Lumileds maintains a tolerance of  $\pm 0.06\text{V}$  on forward voltage measurements.
2. Measured between  $T_j = 25^\circ\text{C} - 110^\circ\text{C}$  at  $I_f = 350\text{mA}$ .
3. Does not include wall plug efficiency.
4. Dynamic resistance is the inverse of the slope in the linear forward voltage model for LEDs. See Forward Voltage vs. Forward Current curves.

## Typical Electrical Characteristics at 700mA for LUXEON Rebel, Junction Temperature, $T_j = 25^\circ\text{C}$

Table 4.

Part Number	Typical Forward Voltage $V_f$ <sup>[1]</sup> (V)
LXMA-PH01-0040	3.60
LXMA-PH01-0050	3.60
LXMA-PH02-0060	2.30
LXMA-PH02-0070	2.30
LXMA-PL01-0023	3.60
LXMA-PL01-0030	3.60
LXMA-PL01-0040	3.60

Notes for Table 4:

1. Lumileds maintains a tolerance of  $\pm 0.06\text{V}$  on forward voltage measurements.

# Absolute Maximum Ratings

Table 5a.

Parameter	Red-Orange/Amber
DC Forward Current (mA)	700
Peak Pulsed Forward Current (mA)	700
Average Forward Current (mA)	700
ESD Sensitivity <sup>[5]</sup>	8kV HBM, 400V MM
LED Junction Temperature <sup>[1][3][4]</sup>	135°C
Operating Case Temperature <sup>[4]</sup>	-40°C - 135°C
Storage Temperature	-40°C - 135°C
Soldering Temperature	JEDEC 020c 260°C
Allowable Reflow Cycles	3
Autoclave Conditions	121°C at 2 ATM 100% Relative Humidity for 96 Hours Maximum
Reverse Voltage (Vr)	See Note 2

Notes for Table 5a:

1. Proper current derating must be observed to maintain junction temperature below the maximum.
2. LUXEON Rebel LEDs are not designed to be driven in reverse bias.
3. LUXEON Rebel Automotive LEDs driven at maximum LED junction temperature will have limited lifetime.
4. Please consult with Lumileds for more information on maximum time durations and forward currents for these temperature ranges.
5. Measured using human body model and machine model (per AEC-Q101C).

# Absolute Minimum Ratings

Table 5b.

Parameter	Red-Orange/Amber
DC Forward Current (mA)	50

# JEDEC Moisture Sensitivity

Table 6.

Level	Floor Life		Soak Requirements	
			Standard	
	Time	Conditions	Time	Conditions
1	unlimited	≤ 30°C / 85% RH	168 Hrs. + 5 / -0 Hrs.	85°C / 85% RH

# Reflow Soldering Characteristics

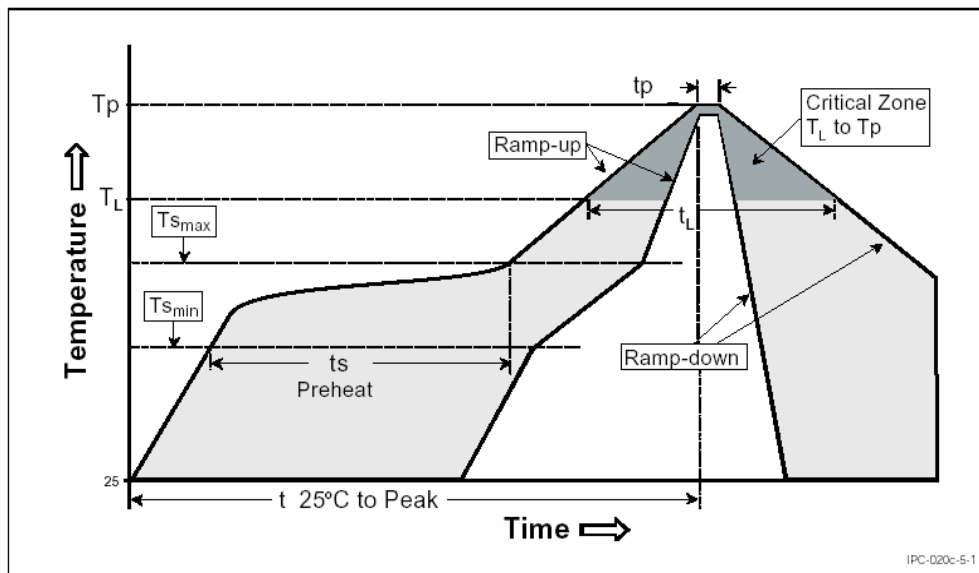

Temperature Profile for Table 7.

Table 7.

Profile Feature	Lead Free Assembly
Average Ramp-Up Rate ( $T_{s_{max}}$ to $T_p$ )	3°C / second max
Preheat Temperature Min ( $T_{s_{min}}$ )	150°C
Preheat Temperature Max ( $T_{s_{max}}$ )	200°C
Preheat Time ( $t_{s_{min}}$ to $t_{s_{max}}$ )	60 - 180 seconds
Temperature ( $T_L$ )	217°C
Time Maintained Above Temperature $T_L$ ( $t_L$ )	60 - 150 seconds
Peak / Classification Temperature ( $T_p$ )	260°C
Time Within 5°C of Actual Peak Temperature ( $t_p$ )	20 - 40 seconds
Ramp - Down Rate	6°C / second max
Time 25°C to Peak Temperature	8 minutes max

Note for Table 7:

- All temperatures refer to the application Printed Circuit Board (PCB), measured on the surface adjacent to the package body.

# Mechanical Dimensions

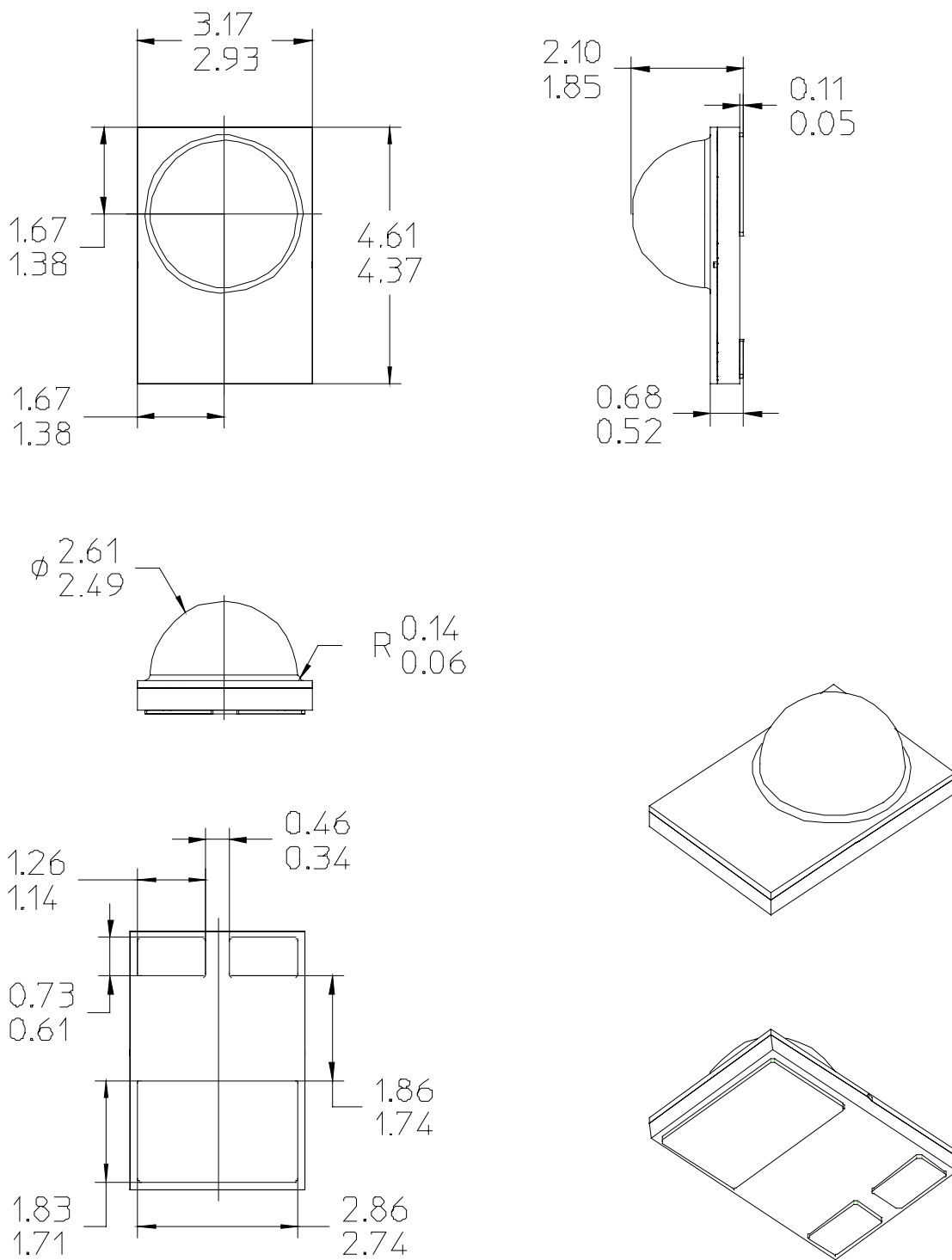

Figure 1. Package outline drawing.

Notes for Figure 1:

1. Do not handle the device by the lens—care must be taken to avoid damage to the lens or the interior of the device that can be damaged by excessive force to the lens.
2. Drawings not to scale.
3. All dimensions are in millimeters.
4. The Thermal Pad is electrically isolated from the Anode and Cathode contact pads.



## Pad Configuration

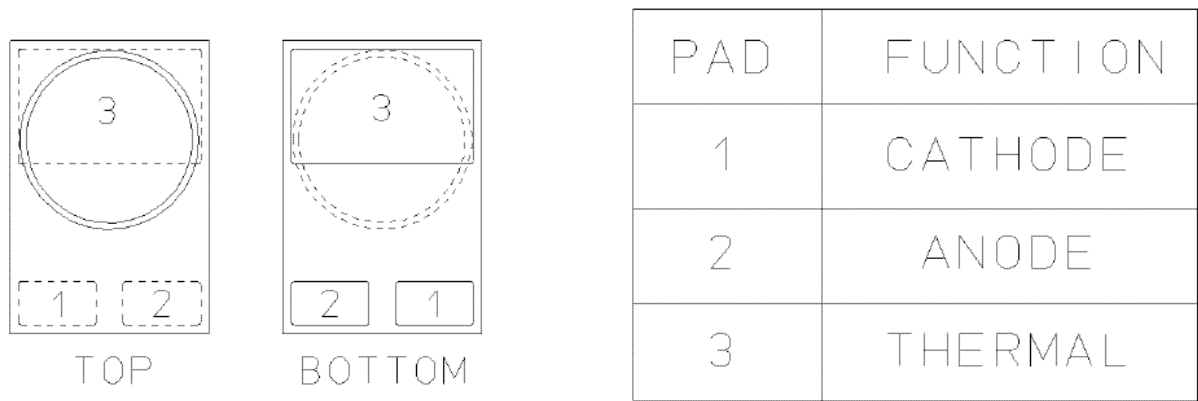

Figure 2. Solder pad layout.

Note for Figure 2:

1. The Thermal Pad is electrically isolated from the Anode and Cathode contact pads.

## Wavelength Characteristics

### Red-Orange and Amber AllnGap at Test Current Thermal Pad Temperature = 25°C

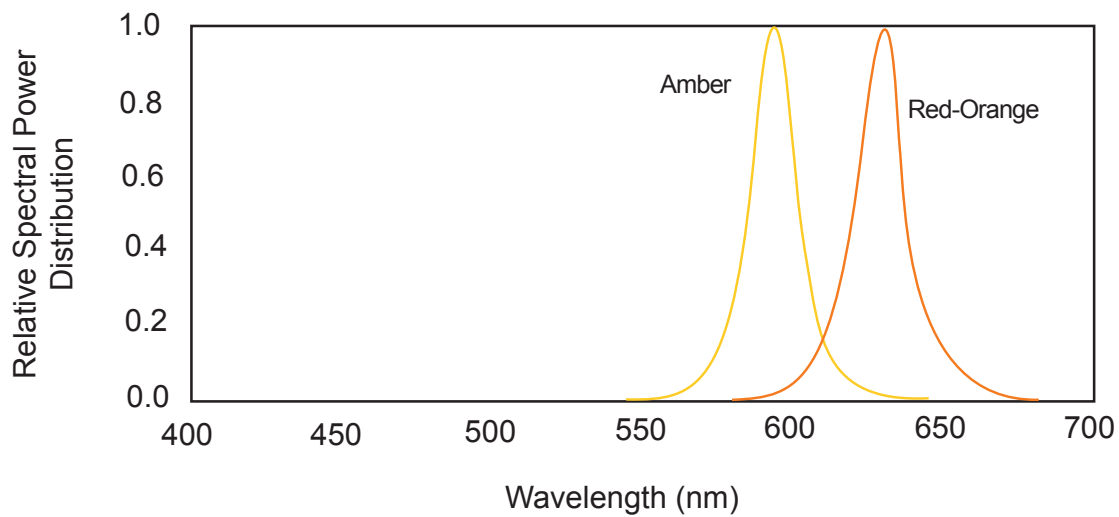

Figure 3. Relative intensity vs. wavelength.

# Typical Light Output Characteristics over Temperature

## Red-Orange and Amber AllnGaP at 350mA Current

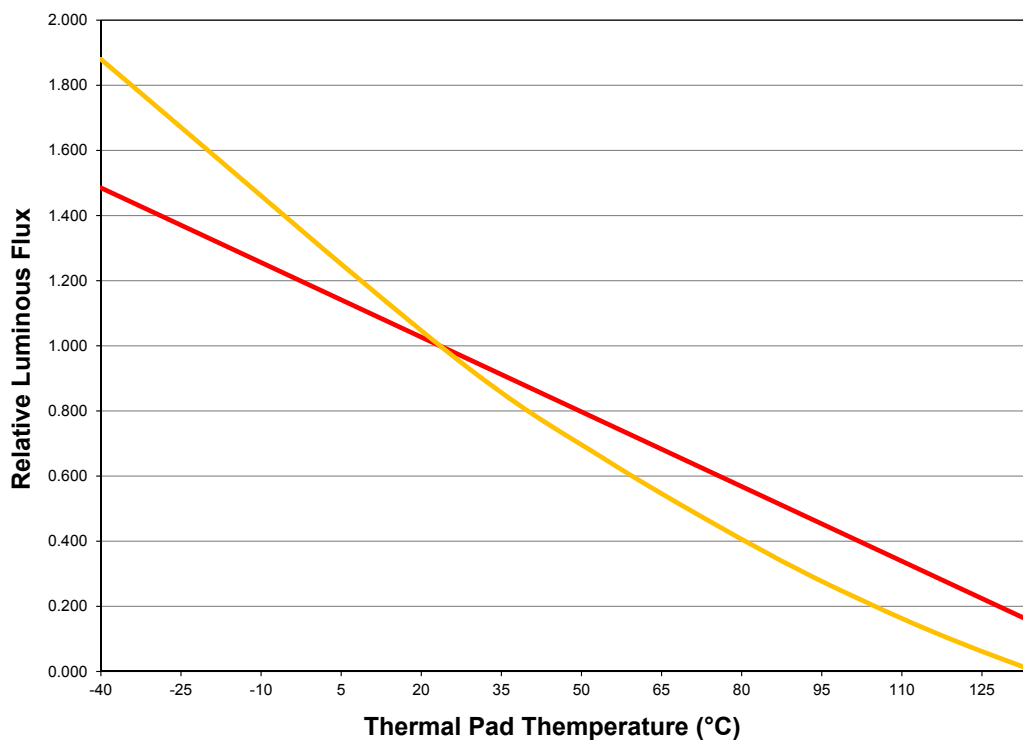

Figure 4. Relative light output vs. thermal pad temperature for red-orange and amber AllnGaP at Test Current (Monopulse Measurement).

Color	Polynomial Fit
Amber	$y = 2.81500000000E-05x^2 - 1.34153300000E-02x + 1.29819647000E+00$
Red Orange	$y = -7.64300000000E-03x + 1.17948800000E+00$

# Typical Forward Voltage Characteristics

Red-Orange and Amber AlInGaP, Thermal Pad Temperature = 25°C

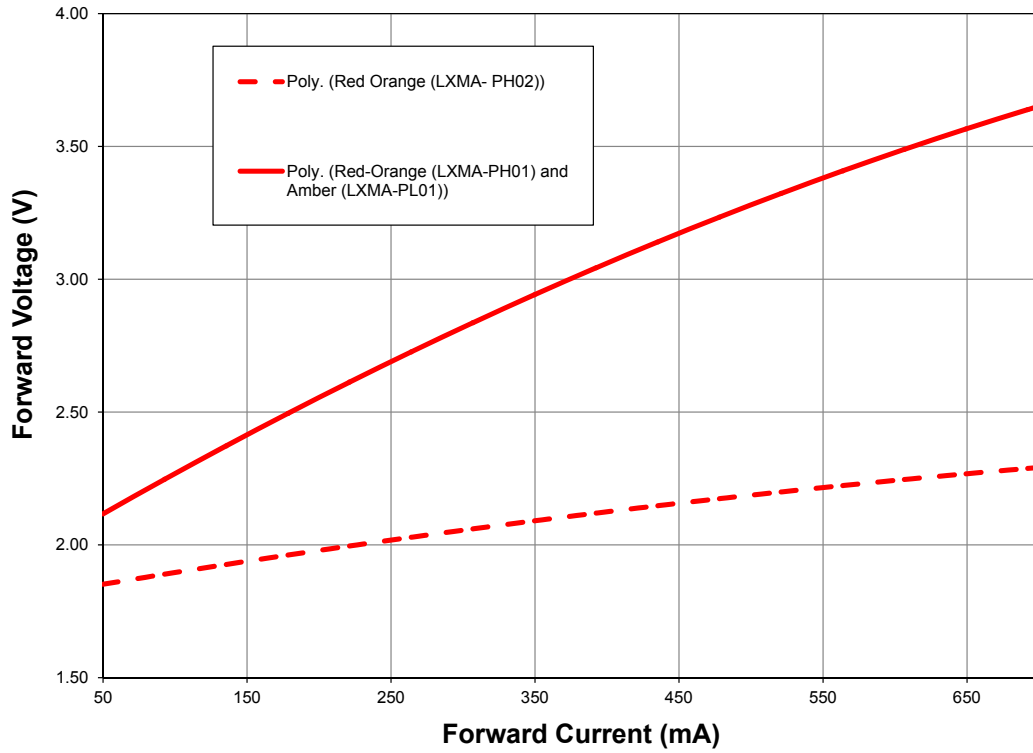

Figure 5. Forward voltage vs. forward current.

Device	Polynomial Fit
Amber PL01 and Red Orange PH01	$y = -1.1193953296E-06x^2 + 3.2006445281E-03x + 1.9594946121E+00$
Red-Orange PH02	$y = -3.4401882893E-07x^2 + 9.3433937396E-04x + 1.8059705056E+00$

# Typical Relative Luminous Flux

Relative Luminous Flux vs. Forward Current for Red-Orange and Amber AllnGaP, Thermal Pad Temperature = 25°C

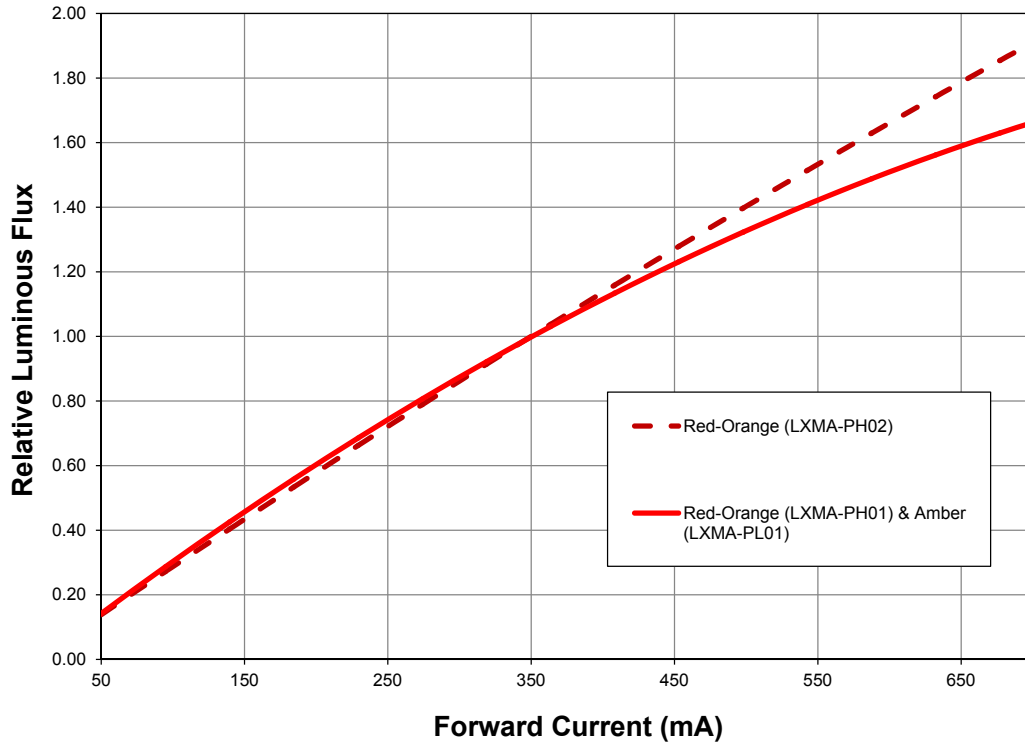

Figure 6. Relative luminous flux vs. forward current for red-orange and amber (Monopulse).

Device	Polynomial Fit
Red-Orange PH01 and Amber PL01	$y = -1.4714610930E-06x^2 + 3.4428129141E-03x - 2.6552643590E-02$
Red-Orange PH02	$y = -4.1673522365E-07x^2 + 3.0391364446E-03x - 1.2535200817E-02$

# Current Derating Curves

## Current Derating Curve for 700mA Drive Current for Red-Orange PH01 and Amber PL01 AlInGaP

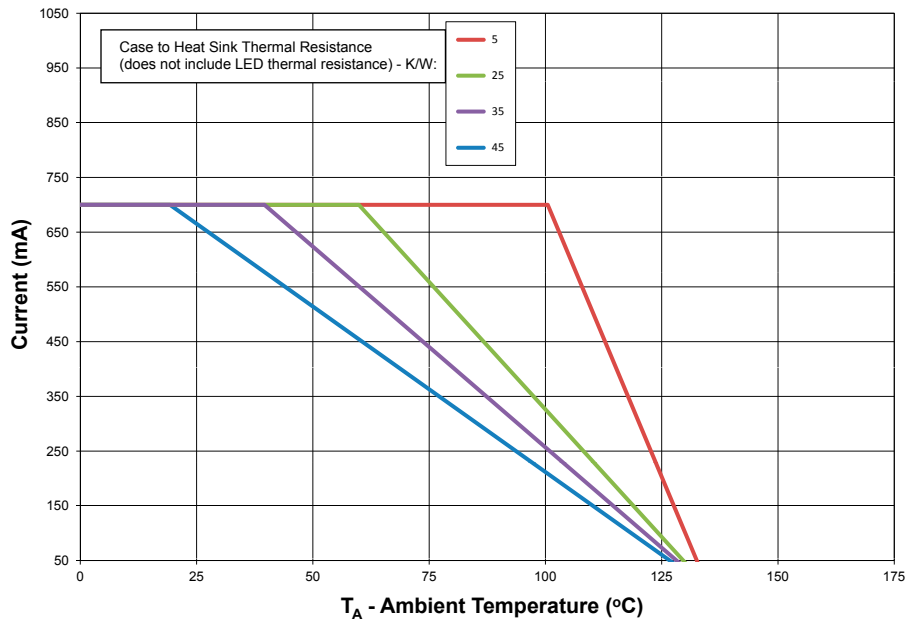

Figure 7. Maximum forward current vs. ambient temperature, based on  $T_{JMAX} = 135^{\circ}C$  for red-orange LXMA-PH01 and amber AlInGaP.

## Current Derating Curve for 700mA Drive Current for Red-Orange PH02 AlInGaP

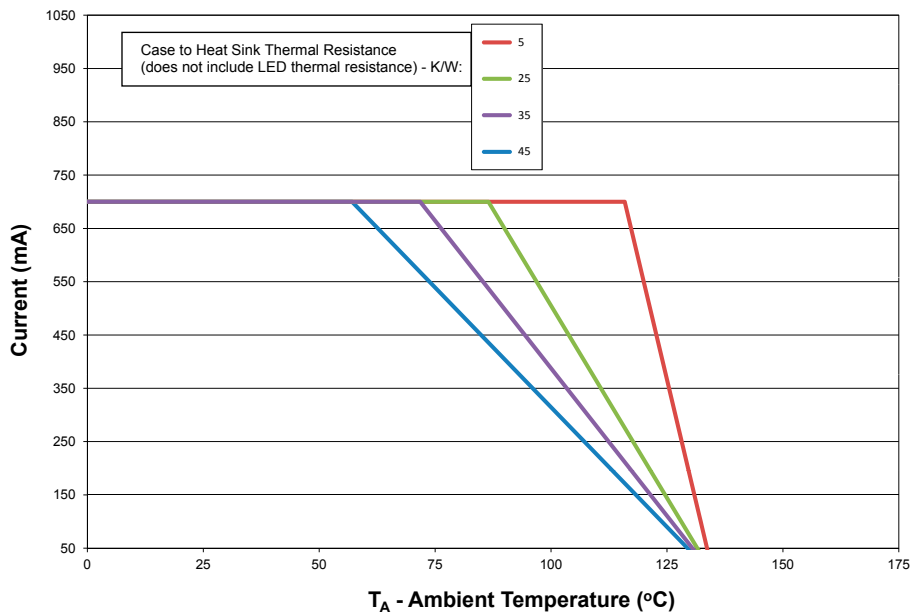

Figure 8. Maximum forward current vs. ambient temperature, based on  $T_{JMAX} = 135^{\circ}C$  for red-orange LXMA-PH02 AlInGaP.

Notes for Figures 7 and 8:

1. Current derating curves represent constant current operation condition.

# Typical Radiation Patterns

## Typical Representative Spatial Radiation Pattern for Red-Orange and Amber AllnGaP Lambertian

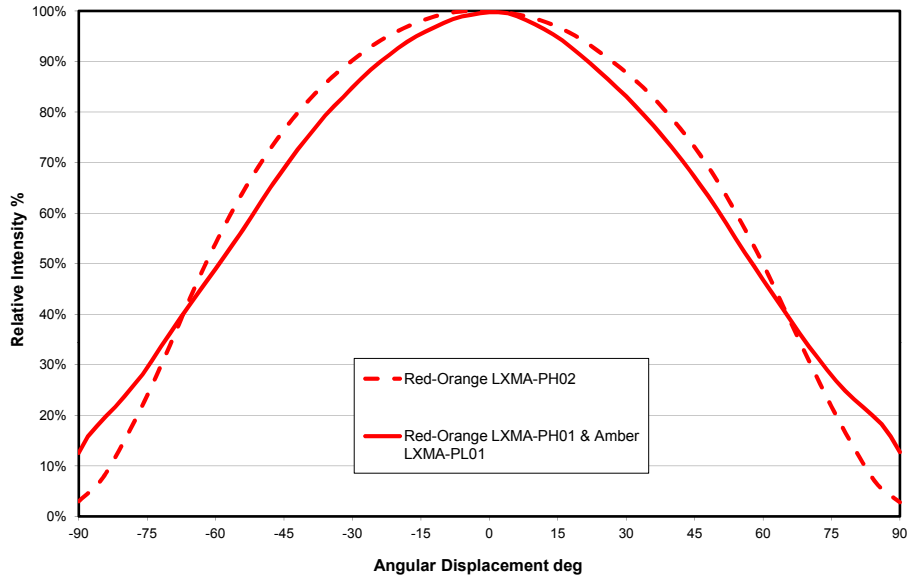

Figure 9. Typical representative spatial radiation pattern for red-orange lambertian (LMXA-PH01) and amber AllnGaP.

## Typical Polar Radiation Pattern for Red-Orange and Amber AllnGaP Lambertian

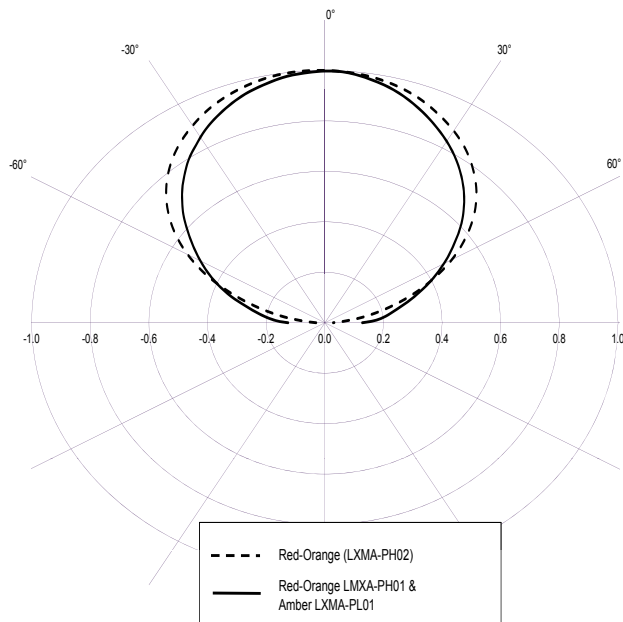

Figure 10. Typical polar radiation pattern for amber.

# Emitter Pocket Tape Packaging

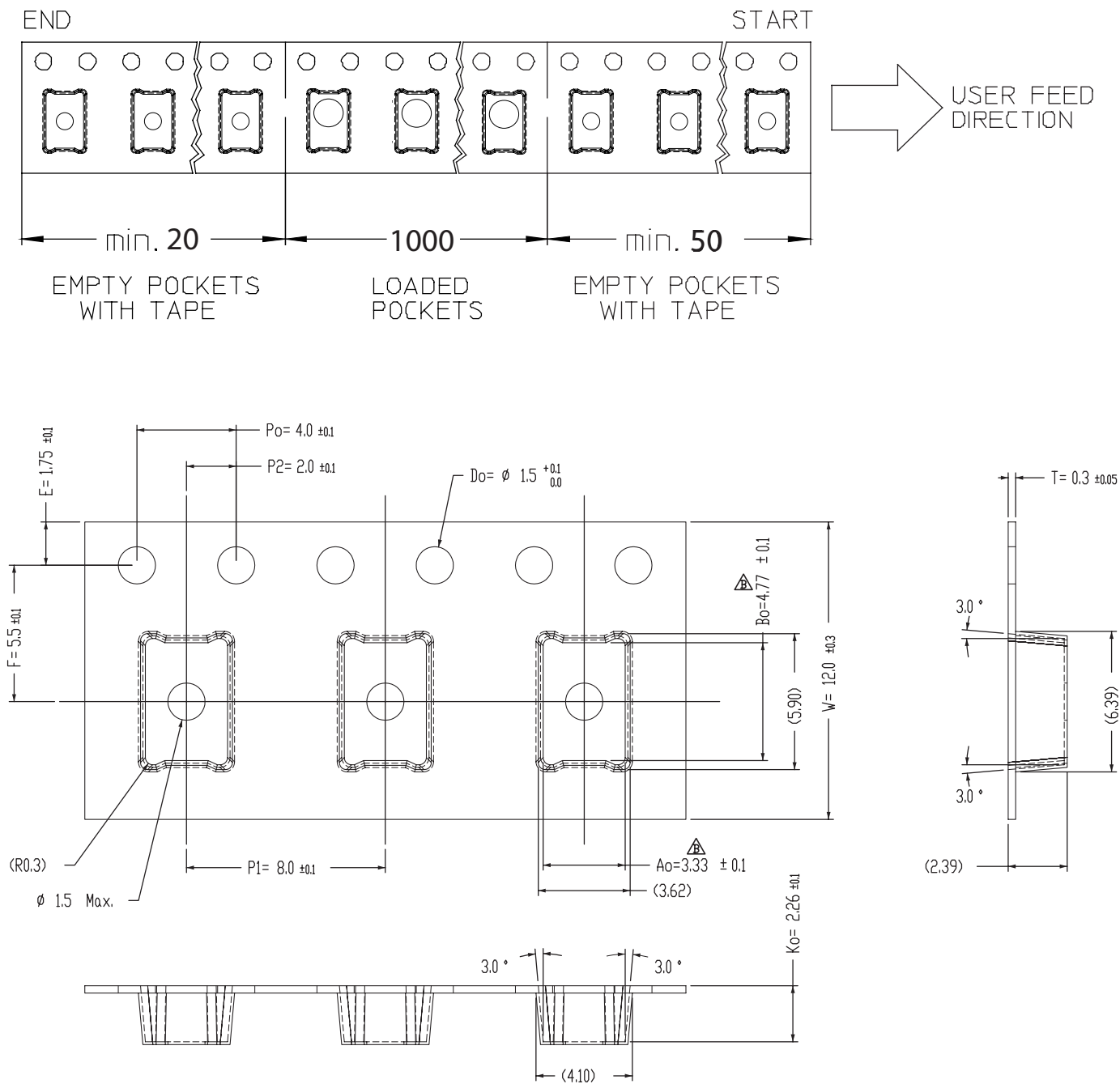

Figure 11. Emitter pocket tape packaging.

Note for Fig 11:

1. SPI 1000.

# Emitter Reel Packaging

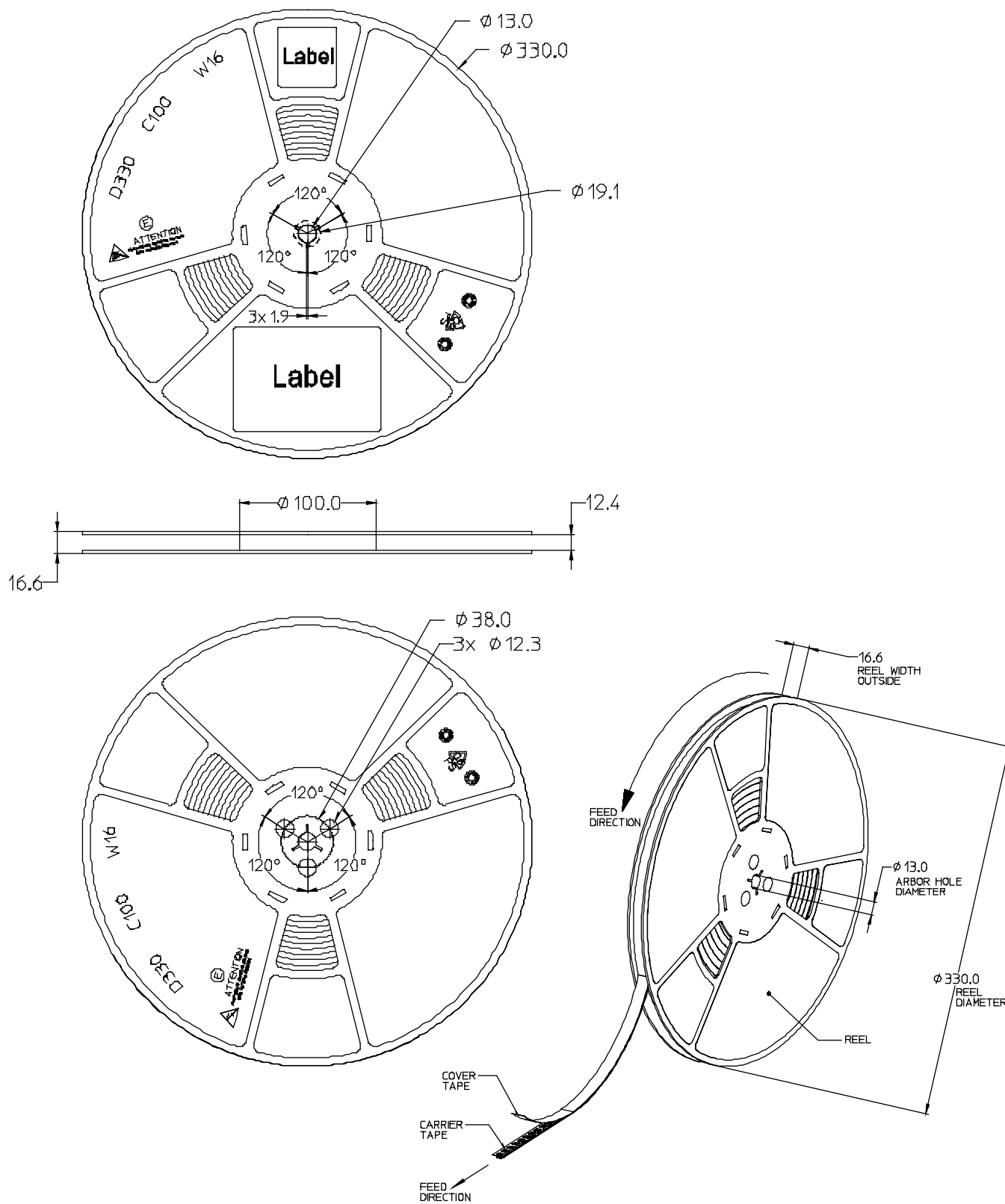

Figure 12. Emitter reel packaging.



# Automotive Product Binning and Labeling

## Purpose of Product Binning

In the manufacturing of semiconductor products, there is a variation of performance around the average values given in the technical data sheets. For this reason, Lumileds bins the LED components for luminous flux, color and forward voltage ( $V_F$ ).

## Decoding Product Bin Labeling

LUXEON Rebel emitters are labeled using a three or four digit alphanumeric code (CAT code) depicting the bin values for emitters packaged on a single reel. All emitters packaged within a reel are of the same 3-variable bin combination. Using these codes it is possible to determine optimum mixing and matching of products for consistency in a given application.

## Format of Labeling for Emitters

Reels of amber emitters are labeled with a three digit alphanumeric CAT code following the format below.

ABC

A = Flux bin (P, Q, R, S, etc.)

B = Color bin (2, 4, etc.)

C =  $V_F$  bin (E, F, G, etc.)

## Luminous Flux Bins

Table 8 lists the standard photometric luminous flux bins for LUXEON Rebel emitters.

Although several bins are outlined, product availability in a particular bin varies by production run and by product performance. Not all bins are available in all colors.

Table 8. Flux Bins - All Colors

Bin Code	Minimum Photometric Flux (lm)	Maximum Photometric Flux (lm)
E	23.5	30
F	30	40
G	40	50
H	50	60
J	60	70
K	70	80
L	80	90
M	90	100

Note for Table 8:

1. Photometric luminous flux bin structure for LUXEON Rebel emitters.

# Color Bin Structure

Red-Orange LUXEON Rebel Emitters for automotive applications are tested and binned for dominant wavelength.

## Dominant Wavelength Color Bin Structure for LUXEON Rebel Red-Orange AlInGaP

Table 9.

Bin Code	Minimum Dominant Wavelength (nm)	Maximum Dominant Wavelength (nm)
2	613.0	620.0

Amber LUXEON Rebel Emitters for automotive applications are tested and binned for dominant wavelength.

## Dominant Wavelength Color Bin Structure for LUXEON Rebel Amber

Table 10.

Bin Code	Minimum Dominant Wavelength (nm)	Maximum Dominant Wavelength (nm)
2	587.0	589.5
4	589.5	592.0

# Forward Voltage Bins

Tables 11 and 12 lists minimum and maximum  $V_F$  bin values per emitter. Although several bins are outlined, product availability in a particular bin varies by production.

Table 11. Forward Voltage Bin Structure for LUXEON Rebel Red-Orange (LXMA-PH01) and Amber (LXMA-PL01) Emitters

Bin Code	Minimum Forward Voltage (V)	Maximum Forward Voltage (V)
A	2.31	2.55
B	2.55	2.79
C	2.79	3.03
D	3.03	3.27
E	3.27	3.51

Table 12. Forward Voltage Bin Structure for LUXEON Rebel Automotive Red-Orange (LXMA-PH02) Emitters

Bin Code	Minimum Forward Voltage (V)	Maximum Forward Voltage (V)
V	1.80	2.00
W	2.00	2.20
X	2.20	2.40
Y	2.40	2.60
Z	2.60	2.80

# About Lumileds

Lumileds is the light engine leader, delivering innovation, quality, and reliability.

For 100 years, Lumileds commitment to innovation has helped customers pioneer breakthrough products in the automotive, consumer and illumination markets.

Lumileds is shaping the future of light with our LEDs and automotive lamps, and helping our customers illuminate how people see the world around them.

To learn more about our portfolio of light engines visit [www.lumileds.com](http://www.lumileds.com).



---

©2015 Lumileds Holding B.V. All rights reserved.  
LUXEON is a registered trademark of the Lumileds Holding B.V.  
in the United States and other countries.

[www.lumileds.com](http://www.lumileds.com)

Neither Lumileds Holding B.V. nor its affiliates shall be liable for any kind of loss of data or any other damages, direct, indirect or consequential, resulting from the use of the provided information and data. Although Lumileds Holding B.V. and/or its affiliates have attempted to provide the most accurate information and data, the materials and services information and data are provided "as is," and neither Lumileds Holding B.V. nor its affiliates warrants or guarantees the contents and correctness of the provided information and data. Lumileds Holding B.V. and its affiliates reserve the right to make changes without notice. You as user agree to this disclaimer and user agreement with the download or use of the provided materials, information and data.

## Данный компонент на территории Российской Федерации

### Вы можете приобрести в компании MosChip.

Для оперативного оформления запроса Вам необходимо перейти по данной ссылке:

<http://moschip.ru/get-element>

Вы можете разместить у нас заказ для любого Вашего проекта, будь то серийное производство или разработка единичного прибора.

В нашем ассортименте представлены ведущие мировые производители активных и пассивных электронных компонентов.

Нашей специализацией является поставка электронной компонентной базы двойного назначения, продукции таких производителей как XILINX, Intel (ex.ALTERA), Vicor, Microchip, Texas Instruments, Analog Devices, Mini-Circuits, Amphenol, Glenair.

Сотрудничество с глобальными дистрибьюторами электронных компонентов, предоставляет возможность заказывать и получать с международных складов практически любой перечень компонентов в оптимальные для Вас сроки.

На всех этапах разработки и производства наши партнеры могут получить квалифицированную поддержку опытных инженеров.

Система менеджмента качества компании отвечает требованиям в соответствии с ГОСТ Р ИСО 9001, ГОСТ РВ 0015-002 и ЭС РД 009

### Офис по работе с юридическими лицами:

105318, г.Москва, ул.Щербаковская д.3, офис 1107, 1118, ДЦ «Щербаковский»

Телефон: +7 495 668-12-70 (многоканальный)

Факс: +7 495 668-12-70 (доб.304)

E-mail: [info@moschip.ru](mailto:info@moschip.ru)

Skype отдела продаж:

moschip.ru

moschip.ru\_4

moschip.ru\_6

moschip.ru\_9