

Si1102 EVALUATION KIT USER'S GUIDE

1. Kit Contents

The Si1102 Evaluation Kit contains the following items:

- Si1102EK evaluation board
- CR2032 battery

2. Hardware Overview

The Si1102EK uses a Silicon Laboratories Si1102 to measure infrared proximity. The Si1102 strobes an infrared LED at a frequency defined by the potentiometer labeled R2. The Si1102 measures the amount of infrared light that reflects onto the Si1102 package. If the reflected light magnitude exceeds a threshold set by the potentiometer labeled R1, the Si1102's PRX output pin latches low, which turns on the blue LED labeled D2. The board is powered by a CR2032 battery, and the supply current can be connected or disconnected from the Si1102 and the LEDs using the switch labeled S1. Header H1 provides access to the Si1102's pins.

Figure 1 shows the Si1102EK board. Table 1 lists the signals connected to each of header H1's pins.

For more information regarding Si1102 functionality, please see the Si1102 data sheet.

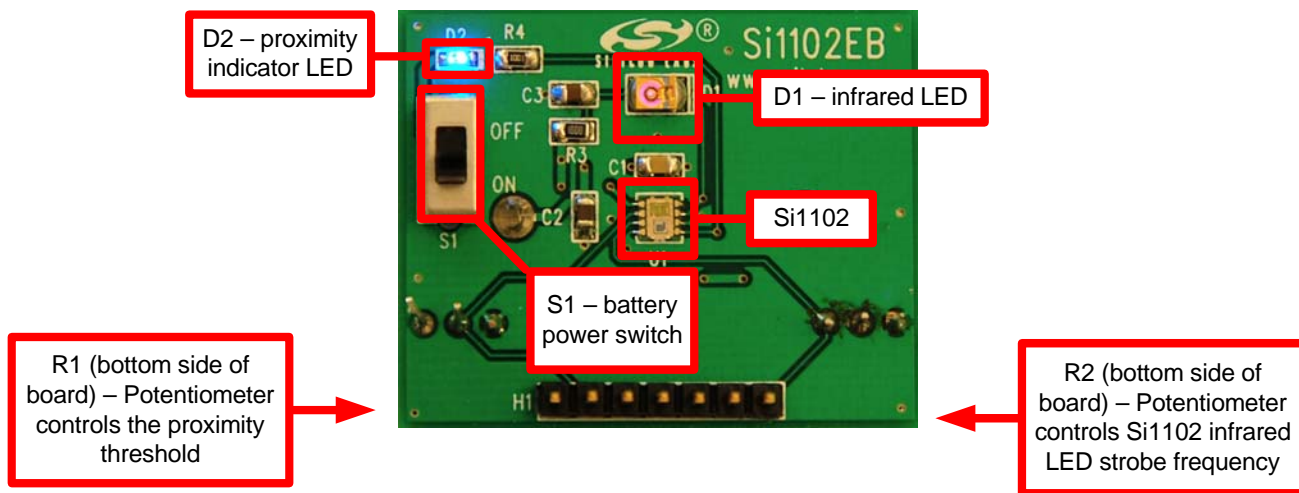

Figure 1. Si1102 Evaluation Kit Board

Table 1. Header H1 Pin-Out

H1 Pin #	Si1102 Pin #	Signal Name
1	2	Ground
2	6	SREN
3	5	VDD
4	1	PRX
5	N/C	N/C
6	3	TXO
7	7	FR

3. Schematics

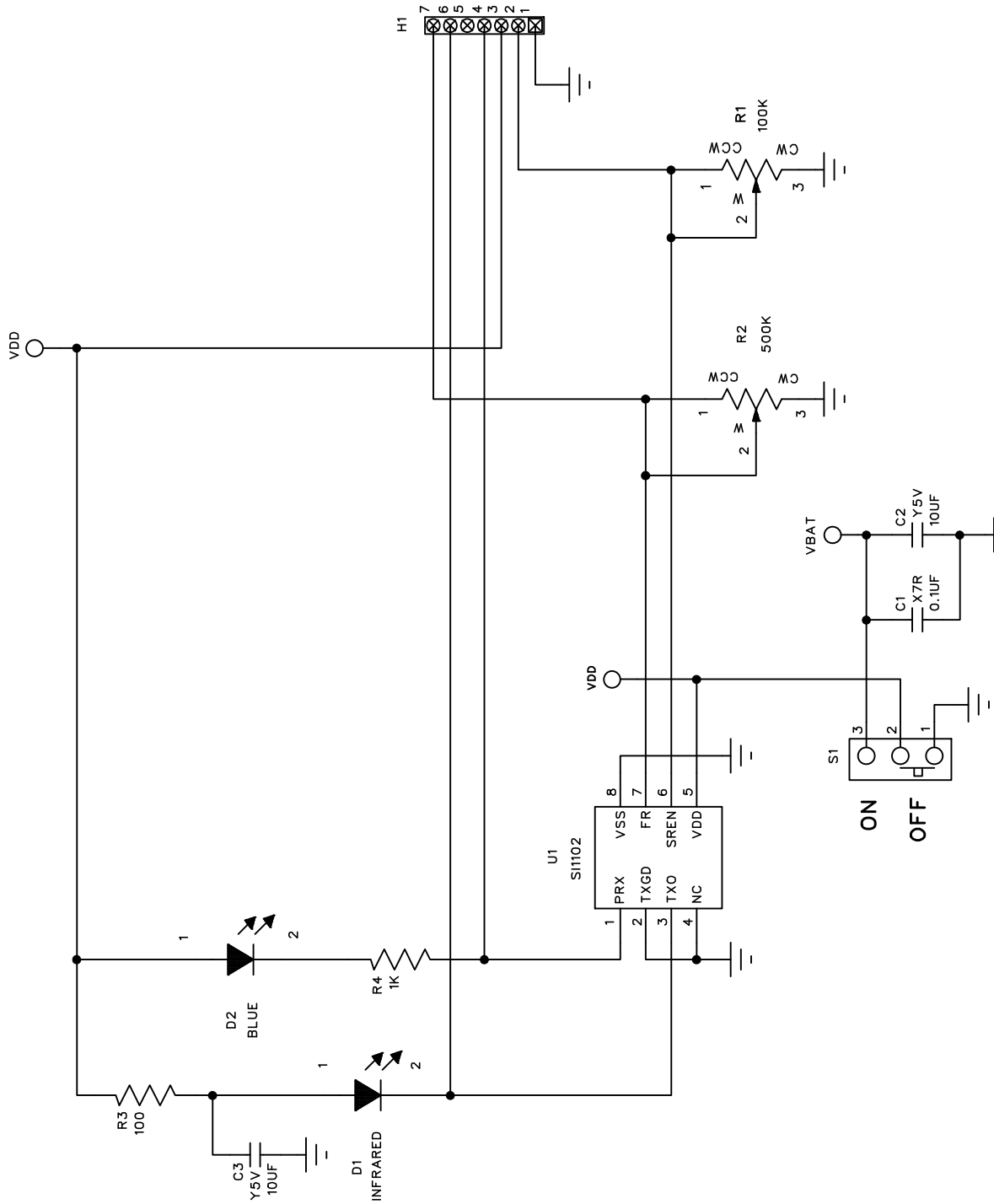

Figure 2. Si1102EK schematic

NOTES:

CONTACT INFORMATION

Silicon Laboratories Inc.
400 West Cesar Chavez
Austin, TX 78701
Tel: 1+(512) 416-8500
Fax: 1+(512) 416-9669
Toll Free: 1+(877) 444-3032

Please visit the Silicon Labs Technical Support web page:
<https://www.silabs.com/support/pages/contacttechnicalsupport.aspx>
and register to submit a technical support request.

The information in this document is believed to be accurate in all respects at the time of publication but is subject to change without notice. Silicon Laboratories assumes no responsibility for errors and omissions, and disclaims responsibility for any consequences resulting from the use of information included herein. Additionally, Silicon Laboratories assumes no responsibility for the functioning of undescribed features or parameters. Silicon Laboratories reserves the right to make changes without further notice. Silicon Laboratories makes no warranty, representation or guarantee regarding the suitability of its products for any particular purpose, nor does Silicon Laboratories assume any liability arising out of the application or use of any product or circuit, and specifically disclaims any and all liability, including without limitation consequential or incidental damages. Silicon Laboratories products are not designed, intended, or authorized for use in applications intended to support or sustain life, or for any other application in which the failure of the Silicon Laboratories product could create a situation where personal injury or death may occur. Should Buyer purchase or use Silicon Laboratories products for any such unintended or unauthorized application, Buyer shall indemnify and hold Silicon Laboratories harmless against all claims and damages.

Silicon Laboratories, Silicon Labs, and QuickSense are trademarks of Silicon Laboratories Inc.
Other products or brandnames mentioned herein are trademarks or registered trademarks of their respective holders.

Данный компонент на территории Российской Федерации

Вы можете приобрести в компании MosChip.

Для оперативного оформления запроса Вам необходимо перейти по данной ссылке:

<http://moschip.ru/get-element>

Вы можете разместить у нас заказ для любого Вашего проекта, будь то серийное производство или разработка единичного прибора.

В нашем ассортименте представлены ведущие мировые производители активных и пассивных электронных компонентов.

Нашей специализацией является поставка электронной компонентной базы двойного назначения, продукции таких производителей как XILINX, Intel (ex.ALTERA), Vicor, Microchip, Texas Instruments, Analog Devices, Mini-Circuits, Amphenol, Glenair.

Сотрудничество с глобальными дистрибьюторами электронных компонентов, предоставляет возможность заказывать и получать с международных складов практически любой перечень компонентов в оптимальные для Вас сроки.

На всех этапах разработки и производства наши партнеры могут получить квалифицированную поддержку опытных инженеров.

Система менеджмента качества компании отвечает требованиям в соответствии с ГОСТ Р ИСО 9001, ГОСТ РВ 0015-002 и ЭС РД 009

Офис по работе с юридическими лицами:

105318, г.Москва, ул.Щербаковская д.3, офис 1107, 1118, ДЦ «Щербаковский»

Телефон: +7 495 668-12-70 (многоканальный)

Факс: +7 495 668-12-70 (доб.304)

E-mail: info@moschip.ru

Skype отдела продаж:

moschip.ru

moschip.ru_4

moschip.ru_6

moschip.ru_9