

VC07-Series Specifications

7.00L x 5.00W x 1.80H (mm)

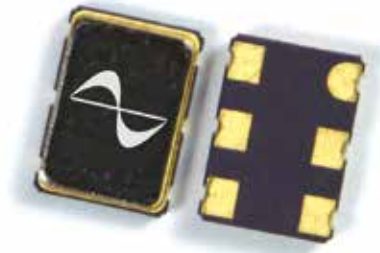

PDI VC07-Series Voltage Controlled Crystal Oscillator (VCXO) ensure a precise frequency under demanding circumstances. With ultra-low phase noise, low jitter, and excellent performance in high vibration environments, this VCXO is offered in both standard and custom frequencies. PDI provides quick-turn sampling for your proto-typing needs, mass production capability, and competitive pricing.

ex) **VC-0-7-25000X-C-B-B-3-R-X***

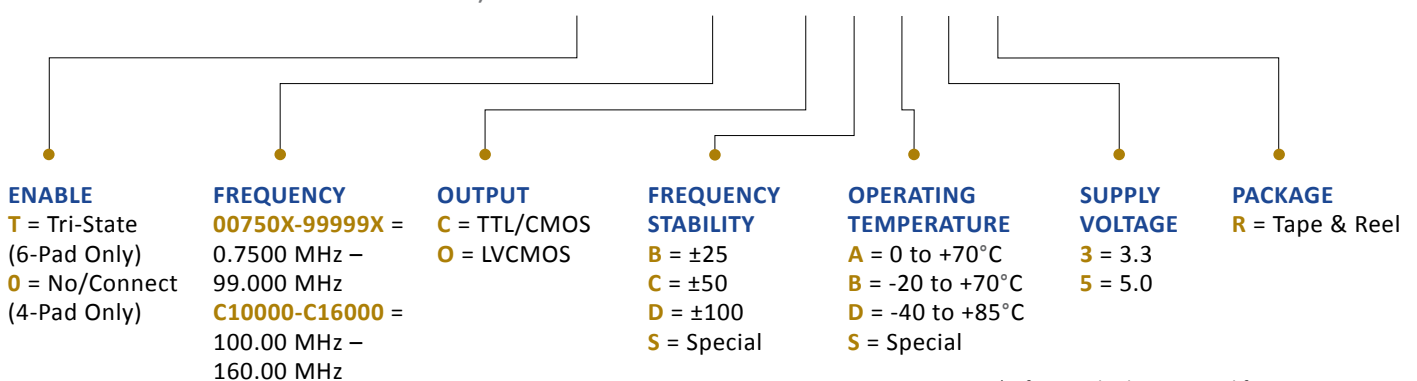

* - for standard or assigned for customization.

Parameter		Supply Voltage* ¹ (±10%)		Units
		5.0	3.3	V
Frequency Range* ¹		0.750000-160.000000		MHz
Frequency Stability* ¹	All Causes (Maximum)* ²	Per Option		ppm
Frequency Adjustment	Control Voltage Range	10 to 90		%Vcc
	Absolute Pull Range (APR) (Minimum)	±50		ppm
	Linearity (Maximum)	10		%
	Input Impedance (Minimum)	50K		Ω
	Modulation Bandwidth (Minimum)	10		KHz
Temperature Range* ¹	Operating	Per Option		°C
	Storage	-55 to +125		
Supply Current (Maximum)	0.750000 to 29.999999 MHz	25	20	mA
	30.000000 to 69.999999 MHz	30	25	
	70.000000 to 160.000000 MHz	60	50	
Output		Per Option		
Load		15pF/10 TTL gates		
Duty Cycle (at 50% Vcc)		40 to 60% (45 to 55% option)		
Rise/Fall Times (Maximum)	Rise Time (10% to 90% Vcc)	5.0		ns
	Fall Time (90% to 10% Vcc)	5.0		
Start up Time (Maximum)		10		ms
Output Voltage Levels	High (Minimum)	90		% Vcc
	Low (Maximum)	10		
Pin 2 (Tri-State) (6-Pad Option Only)	Enable (High Voltage) (Minimum)	70		% Vcc
	Disable (Low Voltage) (Maximum)	30		% Vcc
Phase Noise (Typical For 38.4 MHz)	@ 100Hz Offset	-110		dBc/Hz
	@ 1KHz Offset	-130		
	@ 10KHz Offset	-140		

*1 - Not all Frequency/Temperature/Voltage combinations are available.

*2 - Inclusive of Tolerance @25°C, Operating Temperature, Supply Voltage, Load, Aging, Shock and Vibration.

VC07-Series 7.00 x 5.00 x 1.80 (mm)

PACKAGE DIMENSIONS

Decimal XXX = ± .008, XX = ± .02 Metric [XXX = ± .20], [XX = ± .50]

4-Pad Option
(No Connect)

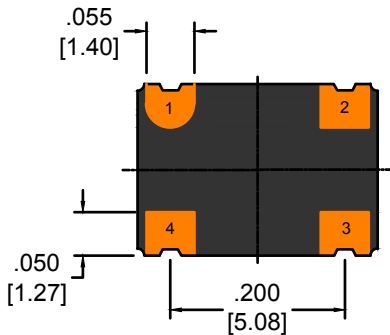
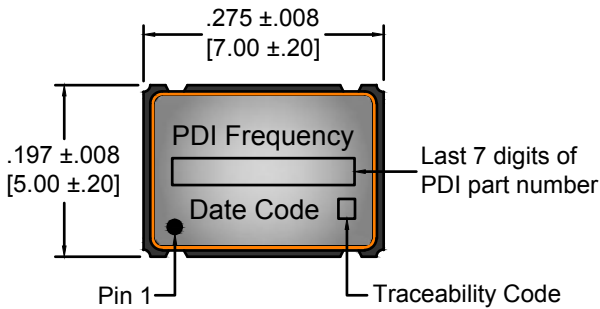

Recommended Land Pattern
(Top View)

PIN	CONNECTION
1	Voltage Control
2	Ground/Case
3	Output
4	Supply Voltage

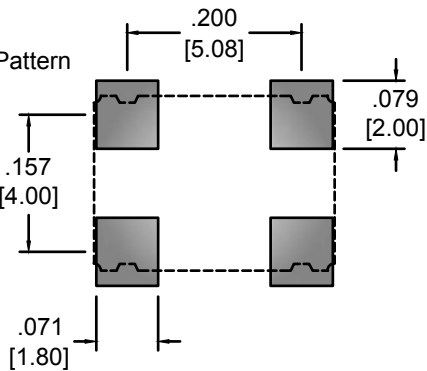

6-Pad Option
(Tri-State)

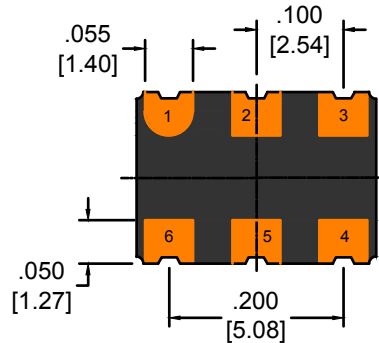
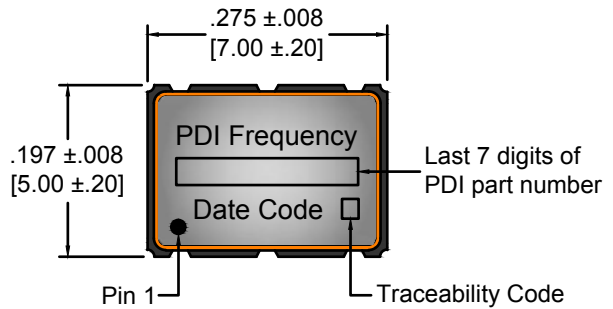

Recommended Land Pattern
(Top View)

PIN	CONNECTION
1	Voltage Control
2	Tri-state
3	Ground/Case
4	Output
5	No Connect
6	Supply Voltage

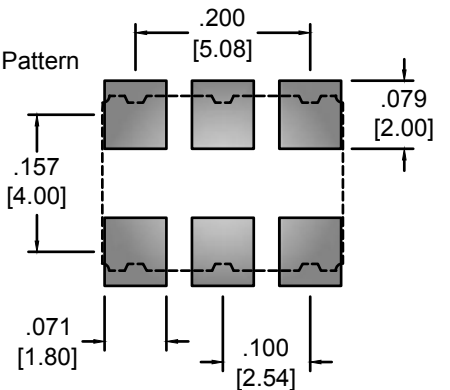

NOTES:

Terminals are Au.
Other options are available, please consult factory.
All product is supplied RoHS and REACH compliant.
Product can be supplied on Tape and Reel, on reels of 1,000 units.
Specifications subject to change without notice, last updated 4/1/13.

VC07-Series 7.00 x 5.00 x 1.80 (mm)

1. Material: Black Conductive Polystyrene or equivalent.
2. 10 Sprocket Hole pitch cumulative tolerance of $\pm .008$.
3. Camber in compliance with EIA 481.
4. Empty pockets: Trailing end (Minimum) 200 mm. and Leading end (Minimum) 400 mm.
5. Pocket position relative to sprocket hole measured as true position of pocket, not pocket hole.

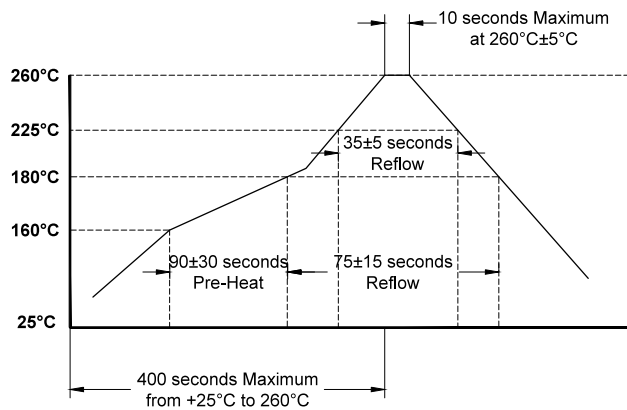
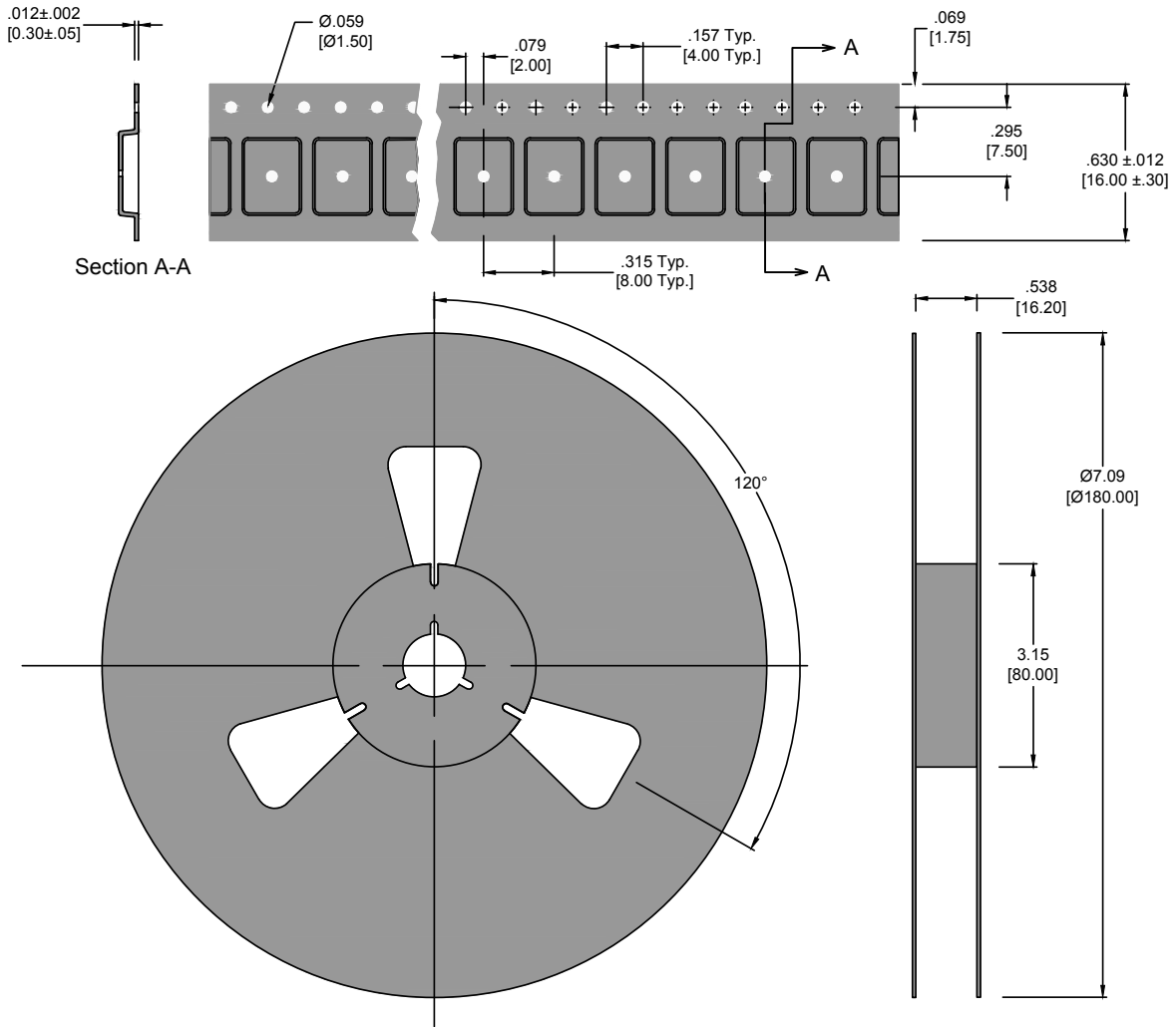

Данный компонент на территории Российской Федерации

Вы можете приобрести в компании MosChip.

Для оперативного оформления запроса Вам необходимо перейти по данной ссылке:

<http://moschip.ru/get-element>

Вы можете разместить у нас заказ для любого Вашего проекта, будь то серийное производство или разработка единичного прибора.

В нашем ассортименте представлены ведущие мировые производители активных и пассивных электронных компонентов.

Нашей специализацией является поставка электронной компонентной базы двойного назначения, продукции таких производителей как XILINX, Intel (ex.ALTERA), Vicor, Microchip, Texas Instruments, Analog Devices, Mini-Circuits, Amphenol, Glenair.

Сотрудничество с глобальными дистрибьюторами электронных компонентов, предоставляет возможность заказывать и получать с международных складов практически любой перечень компонентов в оптимальные для Вас сроки.

На всех этапах разработки и производства наши партнеры могут получить квалифицированную поддержку опытных инженеров.

Система менеджмента качества компании отвечает требованиям в соответствии с ГОСТ Р ИСО 9001, ГОСТ РВ 0015-002 и ЭС РД 009

Офис по работе с юридическими лицами:

105318, г.Москва, ул.Щербаковская д.3, офис 1107, 1118, ДЦ «Щербаковский»

Телефон: +7 495 668-12-70 (многоканальный)

Факс: +7 495 668-12-70 (доб.304)

E-mail: info@moschip.ru

Skype отдела продаж:

moschip.ru

moschip.ru_4

moschip.ru_6

moschip.ru_9