

### 6.2 mm×2.5 mm Side-operational Edge Mount

### Light Touch Switches

Type: **EVQP4**

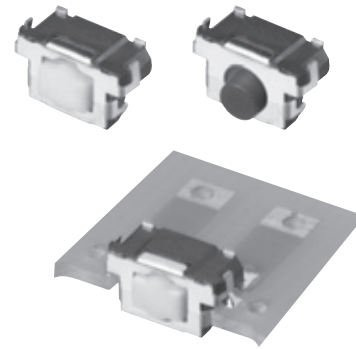

#### ■ Features

- External dimensions : 6.2 mm×2.55 mm (Excluding the push plate), Height 3.5 mm (Printed circuit board being as low as 1.35 mm)
- Side-operational Middle Travel ( 0.7 mm ) with a high operating force (5.0 N)
- Improved soldering strength in the operating direction when mounted on PC board edge

#### ■ Recommended Applications

- Operation switches for portable electronic equipment (Mobile phones, Digital still cameras, Camcorders, Portable audio players, etc.)
- Keyless entry (car electronics)
- Car audio equipment

#### ■ Explanation of Part Numbers

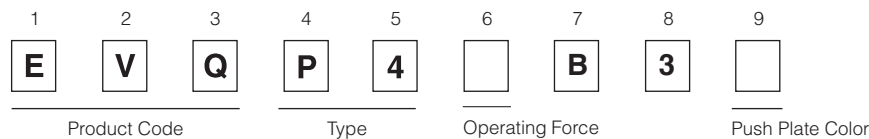



#### ■ Specifications

Travel Type		Middle Travel	Short Travel
Type		Snap action / Push-on type SPST	
Electrical	Rating	10 μA 2 V DC to 20 mA 15 V DC (Resistive load)	
	Contact Resistance	100 mΩ max.	
	Insulation Resistance	100 MΩ min. (at 100 V DC)	
	Dielectric Withstanding Voltage	250 V AC for 1 minute	
	Bouncing	10 ms max. (ON, OFF)	
Mechanical	Operating Force	2.5 N, 3.5 N, 5.0 N	1.0 N, 1.6 N, 2.4 N, 3.5 N
	Travel	0.70 mm±0.2 mm	0.25 mm <sup>+0.05</sup> / <sub>-0.15</sub> mm
	Push Strength	50 N (1 minute)	
Endurance	Operating Life	2.5 N: 1,000,000 cycles min.	1.0 N, 1.6 N: 1,000,000 cycles min.
		3.5 N: 500,000 cycles min.	2.4 N: 500,000 cycles min.
		5.0 N: 200,000 cycles min.	3.5 N: 200,000 cycles min.
Operating Temperature		-40 °C to +85 °C	
Storage Temperature		-40 °C to +85 °C (Bulk) -20 °C to +60 °C (Taping)	
Minimum Quantity/Packing Unit		2,500 pcs. Embossed Taping (Reel Pack)	
Quantity/Carton		12,500 pcs.	

Design and specifications are each subject to change without notice. Ask factory for the current technical specifications before purchase and/or use. Should a safety concern arise regarding this product, please be sure to contact us immediately.

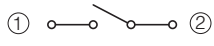
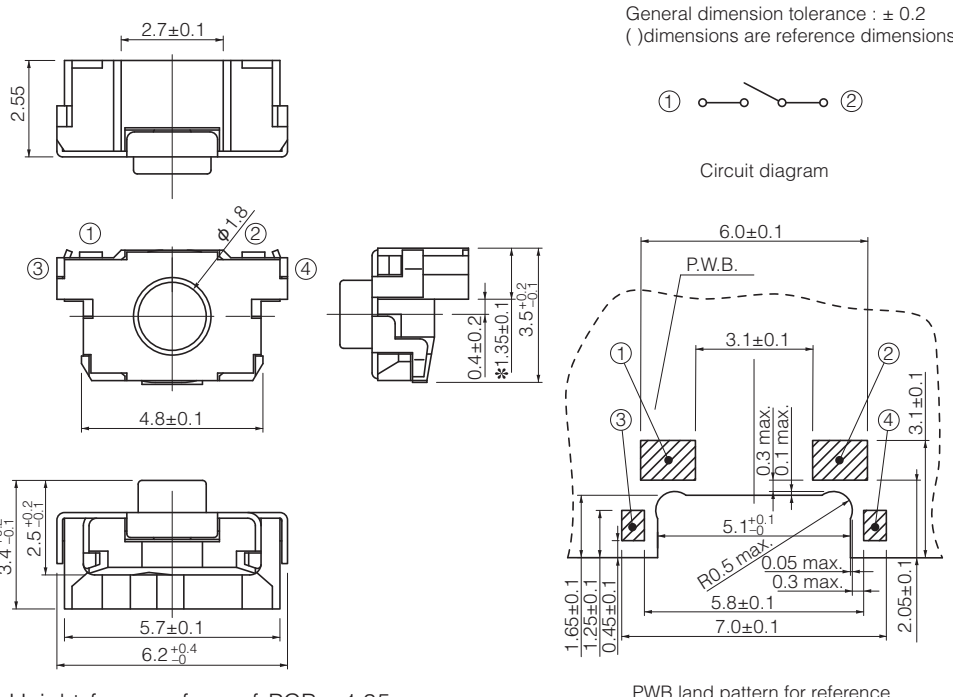
### ■ Dimensions in mm (not to scale)

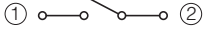
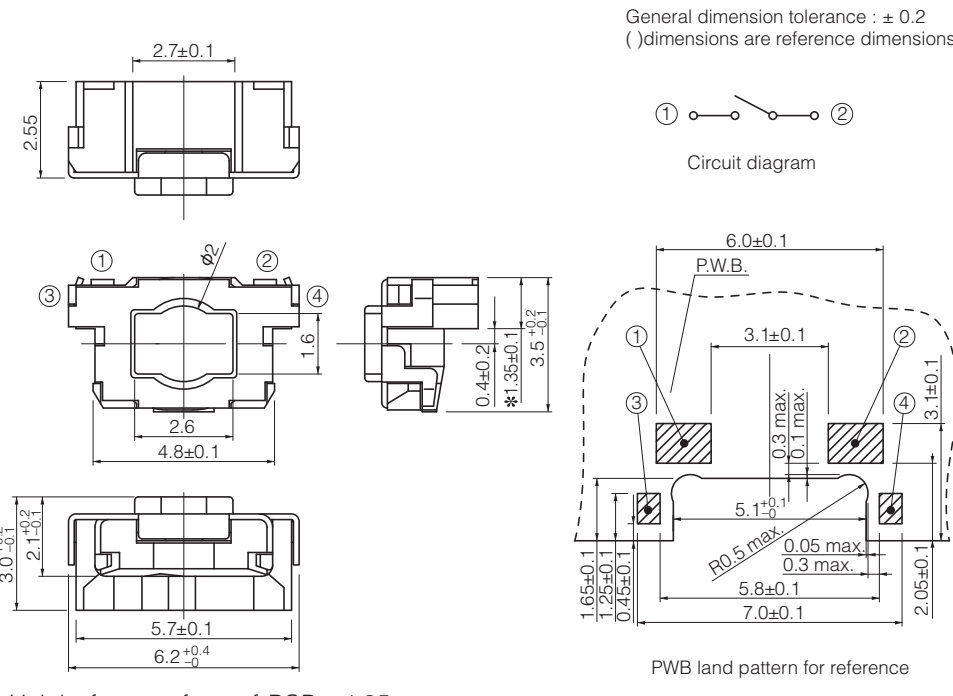
<p>No. 1</p> <p>EVQP4</p> <p>Middle travel</p> 	<p>General dimension tolerance : ± 0.2 ( ) dimensions are reference dimensions.</p>  <p>Circuit diagram</p>  <p>* Height from surface of PCB : 1.35 mm</p>			
<p>Part Numbers</p>	<p>Operating Force</p>	<p>Height</p>	<p>Push Plate Color</p>	<p>Operating Life</p>
<p>EVQP4HB3B</p>	<p>2.5 N</p>	<p>3.5 mm</p>	<p>Blue</p>	<p>1,000,000 cycles</p>
<p>EVQP4KB3Q</p>	<p>3.5 N</p>	<p>3.5 mm</p>	<p>Gray</p>	<p>500,000 cycles</p>
<p>EVQP4MB3K</p>	<p>5.0 N</p>	<p>3.5 mm</p>	<p>Black</p>	<p>200,000 cycles</p>
<p>No. 2</p> <p>EVQP4</p> <p>Short travel</p> 	<p>General dimension tolerance : ± 0.2 ( ) dimensions are reference dimensions.</p>  <p>Circuit diagram</p>  <p>* Height from surface of PCB : 1.35 mm</p>			
<p>Part Numbers</p>	<p>Operating Force</p>	<p>Height</p>	<p>Push Plate Color</p>	<p>Operating Life</p>
<p>EVQP40B3M</p>	<p>1.0 N</p>	<p>3.5 mm</p>	<p>Natural</p>	<p>1,000,000 cycles</p>
<p>EVQP42B3M</p>	<p>1.6 N</p>	<p>3.5 mm</p>	<p>Natural</p>	<p>1,000,000 cycles</p>
<p>EVQP44B3M</p>	<p>2.4 N</p>	<p>3.5 mm</p>	<p>Natural</p>	<p>500,000 cycles</p>
<p>EVQP46B3M</p>	<p>3.5 N</p>	<p>3.5 mm</p>	<p>Natural</p>	<p>200,000 cycles</p>

Design and specifications are each subject to change without notice. Ask factory for the current technical specifications before purchase and/or use.  
Should a safety concern arise regarding this product, please be sure to contact us immediately.

## ■ Recommended Reflow Soldering Conditions

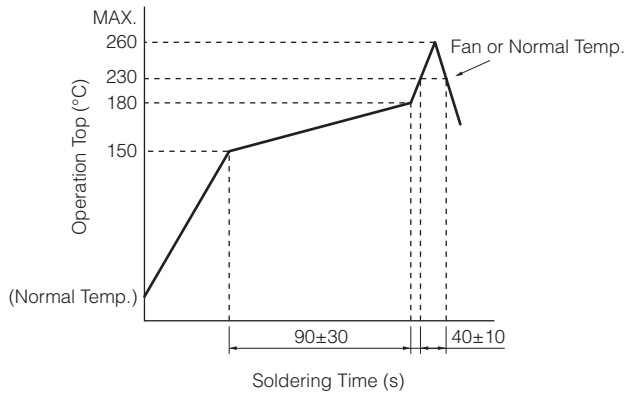

## ● Embossed Carrier Taping

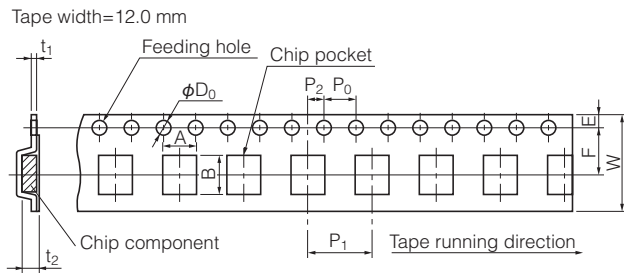

Taping condition : Lack of products in the middle of taping should be one MAX, but total quantity specified in the specifications should be secured.

Peeling off strength of top tape : It should be within 0.2N to 1.0N at 165 degree in peeling off angle.

Joint of carrier tape : One joint per one reel may exist.

Unit: mm

Part No.	Height	A	B	W	F	E	$P_1$	$P_2$	$P_0$	$D_0$ Dia.	$t_1$	$t_2$
EVQP4	3.5	$6.5 \pm 0.2$	$3.9 \pm 0.2$	$12.0 \pm 0.3$	$5.5 \pm 0.1$	$1.75 \pm 0.10$	$8.0 \pm 0.1$	$2.0 \pm 0.1$	$4.0 \pm 0.1$	$1.5_{-0}^{+0.1}$	$0.4 \pm 0.1$	$3.75 \pm 0.20$

# Mouser Electronics

Authorized Distributor

Click to View Pricing, Inventory, Delivery & Lifecycle Information:

## Panasonic:

[EVQ-P4203M](#) [EVQ-P4603M](#) [EVQ-P40B3M](#) [EVQ-P42B3M](#) [EVQ-P44B3M](#) [EVQ-P46B3M](#) [EVQ-P4HB3B](#) [EVQ-P4KB3Q](#) [EVQ-P4MB3K](#) [EVQ-P4003M](#) [EVQ-P4403M](#) [EVQ-P4H03B](#) [EVQ-P4K03Q](#) [EVQ-P4M03K](#)

## Данный компонент на территории Российской Федерации

### Вы можете приобрести в компании MosChip.

Для оперативного оформления запроса Вам необходимо перейти по данной ссылке:

<http://moschip.ru/get-element>

Вы можете разместить у нас заказ для любого Вашего проекта, будь то серийное производство или разработка единичного прибора.

В нашем ассортименте представлены ведущие мировые производители активных и пассивных электронных компонентов.

Нашей специализацией является поставка электронной компонентной базы двойного назначения, продукции таких производителей как XILINX, Intel (ex.ALTERA), Vicor, Microchip, Texas Instruments, Analog Devices, Mini-Circuits, Amphenol, Glenair.

Сотрудничество с глобальными дистрибьюторами электронных компонентов, предоставляет возможность заказывать и получать с международных складов практически любой перечень компонентов в оптимальные для Вас сроки.

На всех этапах разработки и производства наши партнеры могут получить квалифицированную поддержку опытных инженеров.

Система менеджмента качества компании отвечает требованиям в соответствии с ГОСТ Р ИСО 9001, ГОСТ РВ 0015-002 и ЭС РД 009

### Офис по работе с юридическими лицами:

105318, г.Москва, ул.Щербаковская д.3, офис 1107, 1118, ДЦ «Щербаковский»

Телефон: +7 495 668-12-70 (многоканальный)

Факс: +7 495 668-12-70 (доб.304)

E-mail: [info@moschip.ru](mailto:info@moschip.ru)

Skype отдела продаж:

moschip.ru

moschip.ru\_4

moschip.ru\_6

moschip.ru\_9