

Tous droits strictement réservés. Reproduction ou communication à des tiers interdite sous quelque forme que ce soit sans autorisation écrite du propriétaire. Propriété de c FCI. Droits de reproduction FCI.

All rights strictly reserved. Reproduction or issue to third parties in any form whatever is not permitted without written authority from the proprietor. Property of FCI. Copyright FCI.

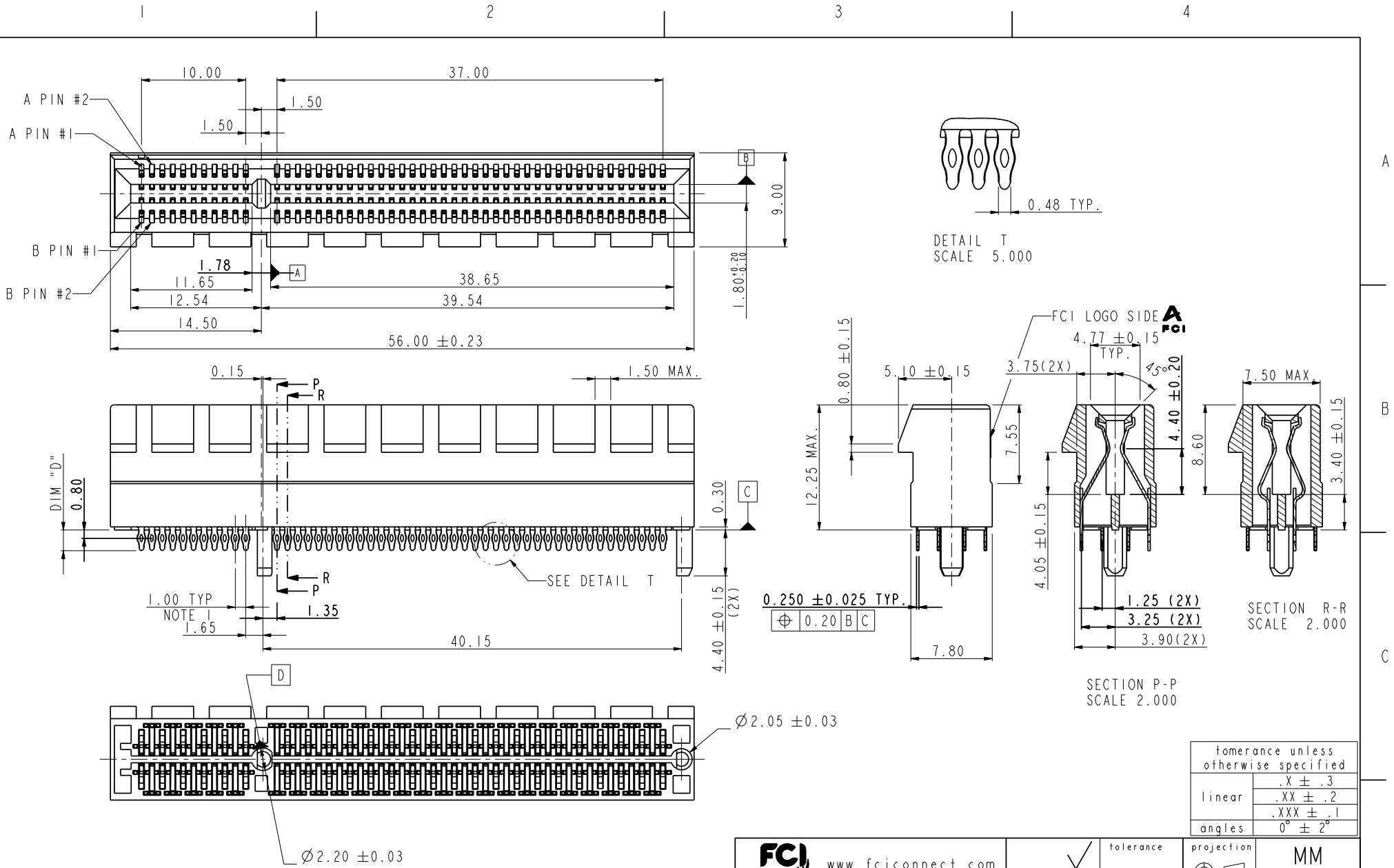

rev	ecn no	dr	date
A	T06-0002	M W	01/05/06
B	DG06-0161	P M	04/11/06
C	DG06-0276	P M	07/05/06

www.fciconnect.com		<input checked="" type="checkbox"/> tolerance	projection	<input checked="" type="checkbox"/> MM
Dr	MAGGIE WU	09/23/05	Product family	
Eng	R Y LIU	09/23/05	Spec ref	
Chr	PAUL WANG	09/23/05	Material	
Appr	JOSEPH HSIA	09/23/05	ECN DG06-0276	
title PCI Express ExpressModule CARD EDGE 98P PRESS-FIT ASS'Y			size A4	Scale 1.000
catalog no			dwg no 10061402	Rev. C

Tous droits strictement réservés. Reproduction ou communication à des tiers interdite sous quelque forme que ce soit sans autorisation écrite du propriétaire. Propriété de c FCI. Droits de reproduction FCI.

All rights strictly reserved. Reproduction or issue to third parties in any form whatever is not permitted without written authority from the proprietor. Property of FCI. Copyright FCI.

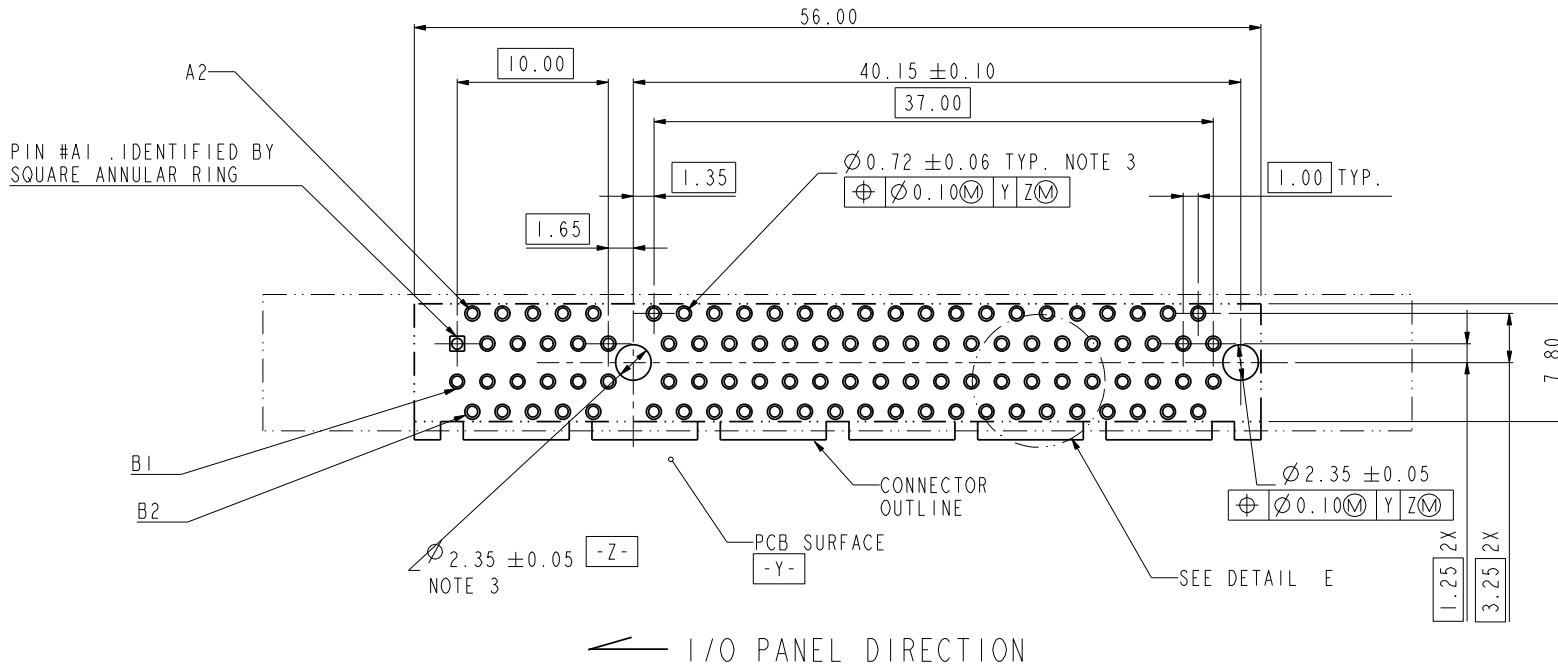

RECOMMENDED FOOTPRINT

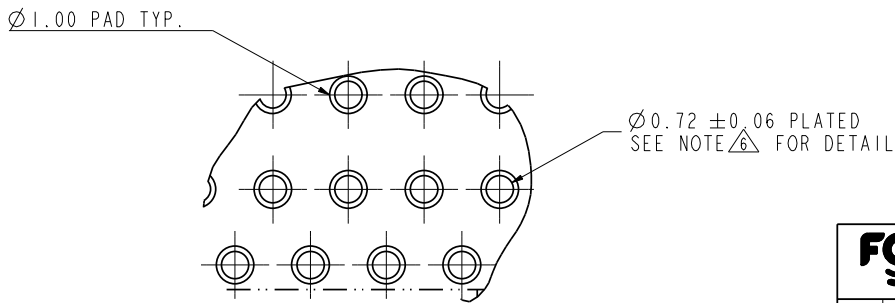

tolerance unless otherwise specified	
linear	.X ± .3 .XX ± .2 .XXX ± .1
angles	0° ± 2°

FCI www.fciconnect.com		✓	tolerance	projection	MM
Dr	MAGGIE WU	09/23/05	Product family	size	A4
Eng	R Y LIU	09/23/05	Spec ref	Scale	1.000
Chr	PAUL WANG	09/23/05	Material	ECN	DG06-0276
Appr	JOSEPH HSIA	09/23/05			

title	PCI Express ExpressModule CARD EDGE 98P PRESS-FIT ASS'Y		dwg no	10061402	Rev.	C
catalog no	PDM: Rev:C		STATUS: Released		CUSTOMER DRAWING sheet 2 of 5 Printed: Mar 15, 2011	

Tous droits strictement réservés. Reproduction ou communication a des tiers interdite sous quelque forme que ce soit sans autorisation écrite du propriétaire. Propriété de c FCI. Droits de reproduction FCI.

All rights strictly reserved. Reproduction or issue to third parties in any form whatever is not permitted without written authority from the proprietor. Property of FCI. Copyright FCI.

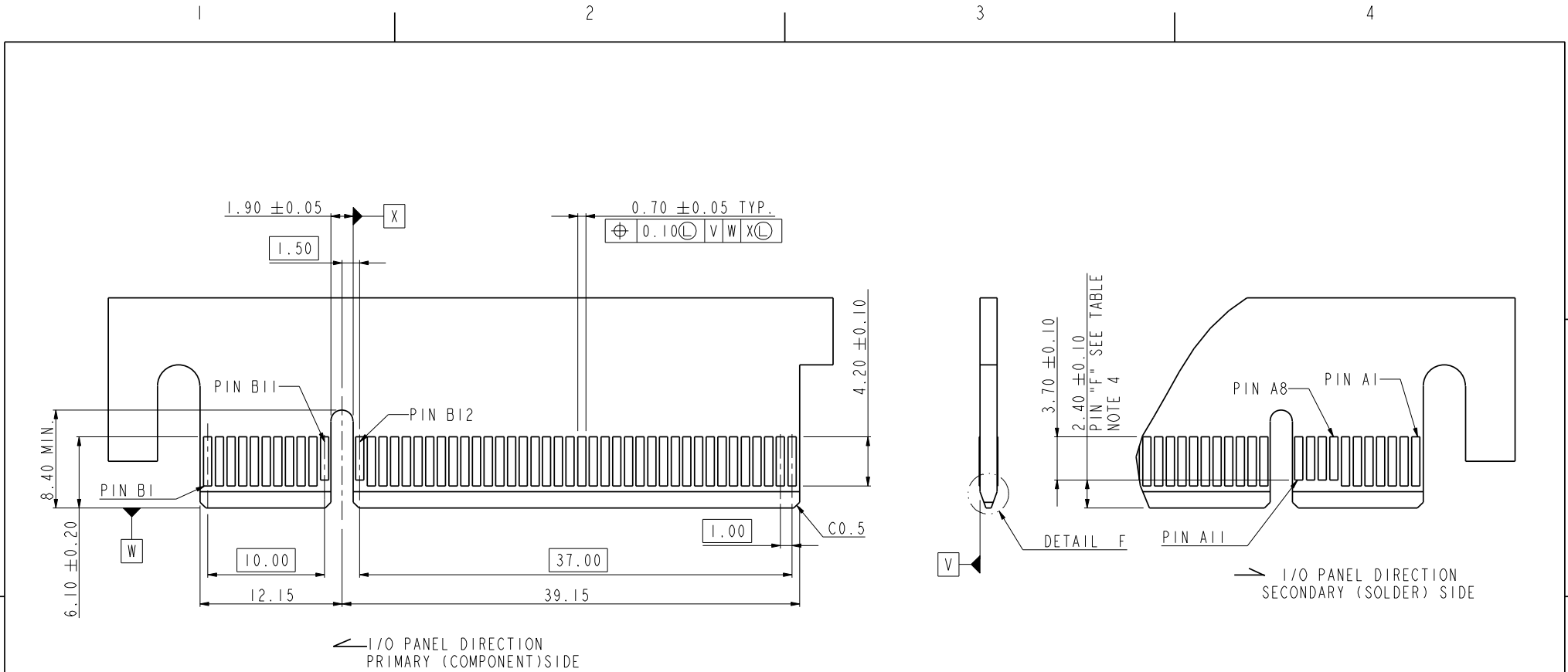

← I/O PANEL DIRECTION
PRIMARY (COMPONENT) SIDE

→ I/O PANEL DIRECTION
SECONDARY (SOLDER) SIDE

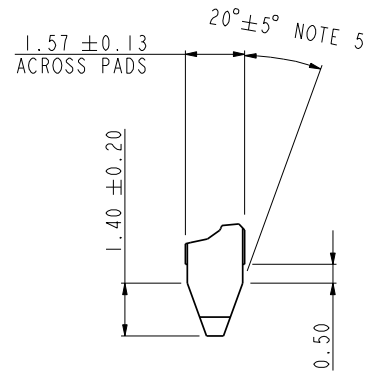

DETAIL F
SCALE 5.000

CONNECTOR LINK WIDE	#POS REF.	"F" NOTE 4
X8	98	A8,A9,A10,A11 B11,B12

tolerance unless otherwise specified	
linear	.X ± .2 .XX ± .13 .XXX ± .05
angles	0° ± 2°

FCI www.fciconnect.com		✓	tolerance	projection	MM
Dr	MAGGIE WU	09/23/05	Product family	size	A4
Eng	R Y LIU	09/23/05	Spec ref	Scale	1.000
Chr	PAUL WANG	09/23/05	Material	ECN	DG06-0276
Appr	JOSEPH HSIA	09/23/05			
title			PCI Express ExpressModule CARD EDGE 98P PRESS-FIT ASS'Y		Rev. C
catalog no			10061402		
PDM: Rev:C			STATUS: Released		Printed: Mar 15, 2011

Tous droits strictement reserves. Reproduction ou communication a des tiers interdite sous quelque forme que ce soit sans autorisation écrite du propriétaire. Propriete de c FCI. Droits de reproduction FCI.

All rights strictly reserved. Reproduction or issue to third parties in any form whatever is not permitted without written authority from the proprietor. Property of FCI. Copyright FCI.

NOTES:

1. MATERIAL:
HOUSING: HIGH TEMPERATURE NYLON, GLASS FILLED UL94V-0 RATED. SUITABLE FOR REFLOW SOLDERING.
TERMINAL: COPPER ALLOY
PLATING: 50u" NICKEL UNDERPLATE ALL OVER
CONTACT AREA PLATING - SEE PRODUCT NUMBER CODE
SOLDER TAIL: TIN - 100u" MIN. OVER 50u" NICKEL OR TIN/LEAD 100u" MIN. SEE PRODUCT NUMBER CODE
2. PRODUCT SPECIFICATION: GS-12-319
3. THE HORIZONTAL AXIS FOR THE HOLE PATTERN IS ESTABLISHED BY A LINE THROUGH THE CENTER OF THE TWO Ø2.35 HOLES.
THE VERTICAL AXIS IS 90° TO THE HORIZONTAL AXIS, THROUGH THE CENTER OF DATUM Z.
4. NO TIE BAR PERMITTED FROM CARD EDGE TO LEADING EDGE OF PAD FOR PINS A1 AND PIN NUMBERS "F".
5. CHAMFER EDGES MUST BE FREE OF CUTTING BURRS.
6. ALL PLATED THRU HOLES SHOULD BE 0.76-0.83 mm DIA DRILLED AND 0.025mm ~ 0.05mm. ELECTRO-DEPOSITED COPPER THK ON THROUGH HOLE WALL.
7. ROHS COMPATIBLE PRODUCT SPECIFICATIONS
a-PLATING:
- "LF" MEANS THE PRODUCT IS LEAD-FREE, 2um MINIMUM MATTE TIN OVER 1.27um MINIMUM NICKEL UNDERPLATE.
b-MANUFACTURING PROCESS COMPATIBILITY
- THE HOUSING WILL WITHSTAND EXPOSURE TO 260°C±5°C SOLDER BATH TEMPERATURE FOR 10 SECONDS IN A REFLOW SOLDER APPLICATION WITH A 2.36mm AND 4.19mm MIN THICK CIRCUIT BOARD.

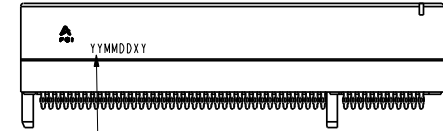

Date code:
"YY" means year number
"MM" means month number
"DD" means day number
"X" means manufacture location
"D" means made in Dongguan site
"Y" means shift number
If date code is 060626D1, it means this part is made by shift 1 in 2006/06/26 and manufactured in Dongguan site
Date code should be laser mark

PRODUCT NUMBER CODE

10061402 - X X X X X X X X

HOUSING COLOR OPTIONS
1-BLACK

PEGS OPTIONS
0-PLASTIC PEGS

TERMINAL PLATING OPTIONS
0-50u" Ni UNDERPLATE
30u" Au CONTACT AREA
100u" TIN TAIL AREA -----COMPATIBLE ROHS

3-50u" Ni UNDERPLATE
30u" Au CONTACT AREA
100u" TIN/LEAD TAIL AREA -----ROHS COMPLIANT EXCEPT Pb

LEAD FREE OPTION
"LF" FOR TERMINAL PLATING OPTION 0
LEAVE BLANK FOR TERMINAL PLATING OPTION 3

PACKAGING OPTIONS
T-TRAY PACKAGING

RESERVE
0

TAIL LENGTH OPTIONS

	DIM "D"	SUGGESTED PCB THICKNESS
0	2.00±0.20	2.36
1	3.25±0.20	4.19

tolerance unless otherwise specified	
linear	.X ± .3 .XX ± .2 .XXX ± .1
angles	0° ± 2°

FCI www.fciconnect.com		✓	tolerance	projection	MM
Dr	MAGGIE WU	09/23/05	Product family		size A4
Eng	R Y LIU	09/23/05	Spec ref		Scale 1.000
Chr	PAUL WANG	09/23/05	Material		ECN DG06-0276
Appr	JOSEPH HSIA	09/23/05			

title	PCI Express ExpressModule CARD EDGE 98P PRESS-FIT ASS'Y		dwg no	10061402	Rev. C
catalog no	PDM: Rev:C		STATUS: Released		CUSTOMER DRAWING sheet 4 of 5 Printed: Mar 15, 2011

Tous droits strictement reserves. Reproduction ou communication a des tiers interdite sous quelque forme que ce soit sans autorisation ecrite du proprietaire. Propriete de c FCI. Droits de reproduction FCI.



All rights strictly reserved. Reproduction or issue to third parties in any form whatever is not permitted without written authority from the proprietor. Property of FCI. Copyright FCI.

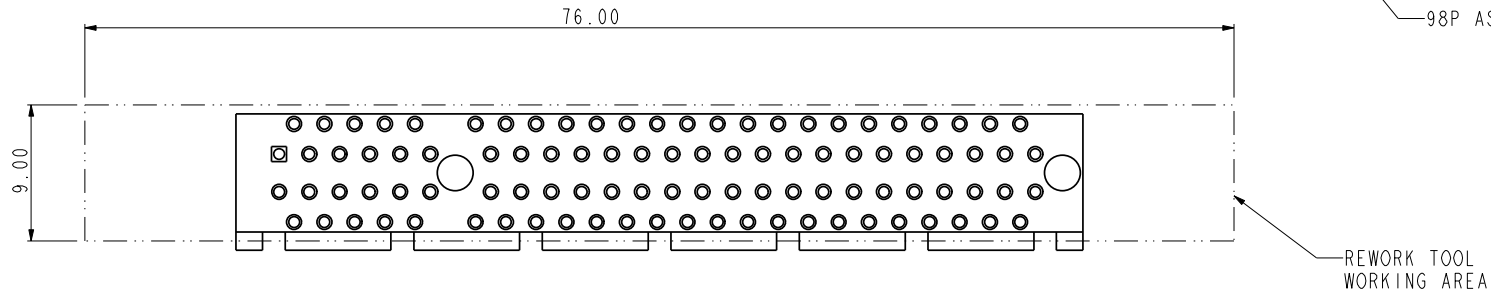

SCALE 2.000

		www.fciconnect.com		✓	tolerance	projection	
Dr	MAGGIE WU	09/23/05	Product family		size	A4	Scale
Eng	R Y LIU	09/23/05	Spec ref				1.000
Chr	PAUL WANG	09/23/05	Material		ECN	DG06-0276	
Appr	JOSEPH HSIA	09/23/05					
title			PCI Express ExpressModule CARD EDGE 98P PRESS FIT ASS'Y		dwg no	10061402	
catalog no			PDM: Rev:C		STATUS: Released	CUSTOMER	sheet 5 of 5
					Printed: Mar 15, 2011		
					Rev. C		

Данный компонент на территории Российской Федерации

Вы можете приобрести в компании MosChip.

Для оперативного оформления запроса Вам необходимо перейти по данной ссылке:

<http://moschip.ru/get-element>

Вы можете разместить у нас заказ для любого Вашего проекта, будь то серийное производство или разработка единичного прибора.

В нашем ассортименте представлены ведущие мировые производители активных и пассивных электронных компонентов.

Нашей специализацией является поставка электронной компонентной базы двойного назначения, продукции таких производителей как XILINX, Intel (ex.ALTERA), Vicor, Microchip, Texas Instruments, Analog Devices, Mini-Circuits, Amphenol, Glenair.

Сотрудничество с глобальными дистрибьюторами электронных компонентов, предоставляет возможность заказывать и получать с международных складов практически любой перечень компонентов в оптимальные для Вас сроки.

На всех этапах разработки и производства наши партнеры могут получить квалифицированную поддержку опытных инженеров.

Система менеджмента качества компании отвечает требованиям в соответствии с ГОСТ Р ИСО 9001, ГОСТ РВ 0015-002 и ЭС РД 009

Офис по работе с юридическими лицами:

105318, г.Москва, ул.Щербаковская д.3, офис 1107, 1118, ДЦ «Щербаковский»

Телефон: +7 495 668-12-70 (многоканальный)

Факс: +7 495 668-12-70 (доб.304)

E-mail: info@moschip.ru

Skype отдела продаж:

moschip.ru

moschip.ru_4

moschip.ru_6

moschip.ru_9