



SEA05L

Advanced constant voltage and constant current controller with very efficient LED pilot-lamp driver

Preliminary data

Features

- Constant voltage and constant current control
- Very efficient LED pilot-lamp driver
- Wide operating V_{CC} range (3.5 V - 36 V)
- Low quiescent consumption: 250 μ A
- Voltage reference: 2.5 V
- Voltage control loop accuracy $\pm 0.5\%$
- Current sense threshold: 50 mV
- Current control loop accuracy $\pm 4\%$
- Low external component count
- Open-drain output stage
- SOT23-6L package

Applications

- AC-DC adapter with LED pilot-lamp
- Battery chargers with LED pilot-lamp
- SMPS with LED pilot-lamp

Description

The device is a highly integrated solution for SMPS applications, with an LED pilot-lamp requiring a dual control loop to perform CV (constant voltage) and CC (constant current) regulation.

The IC allows very efficient LED pilot-lamp driving which helps to reduce the standby consumption of the SMPS. It integrates a voltage reference, two op-amps (with OR-ed open-drain outputs), a low-side current sensing circuit and an LED pilot-lamp driver pin implemented with an open-drain mosfet driven by square waveform with 12.5% duty cycle at 1 kHz that allows reducing LED consumption.

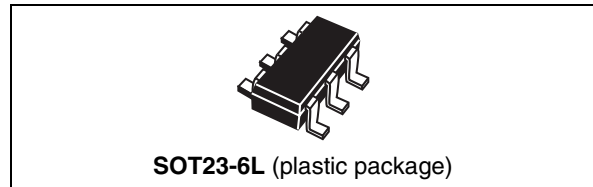
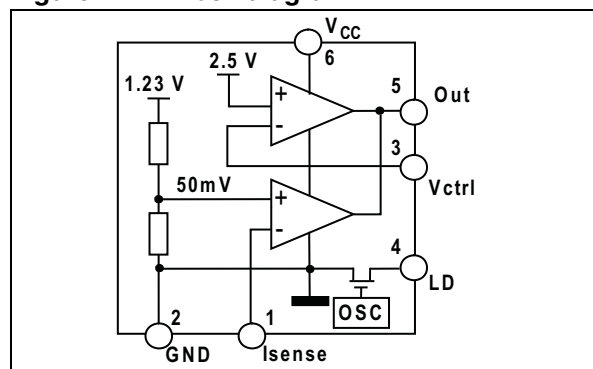

Figure 1. Block diagram



The voltage reference, along with one op-amp, is the core of the voltage control loop. The current sensing circuit and the other op-amp make up the current control loop.

The external components needed to complete the two control loops are:

- a resistor divider that senses the output of the power supply and fixes the voltage regulation setpoint at the specified value
- a sense resistor that feeds the current sensing circuit with a voltage proportional to the DC output current; this resistor determines the current regulation setpoint and must be adequately rated in terms of power dissipation
- the frequency compensation components (R-C networks) for both loops.

The device is ideal for space-critical applications.

Table 1. Device summary

| Order code | Package | Packing |
|------------|----------|-------------|
| SEA05LTR | SOT23-6L | Tape & reel |

Contents

| | | |
|----------|---------------------------------------|-----------|
| 1 | Operation | 3 |
| 2 | Application information | 6 |
| | 2.1 Voltage and current control | 6 |
| | 2.2 Compensation | 8 |
| | 2.3 LD pin function | 8 |
| 3 | Package mechanical data | 10 |
| 4 | Revision history | 11 |

1 Operation

Table 2. Absolute maximum ratings

| Symbol | Pin | Parameter | Value | Unit |
|-------------|-----|--------------------|-----------------------------|------|
| V_{CC} | 6 | DC supply voltage | -0.3 to 38 | V |
| V_{out} | 5 | Open-drain voltage | -0.3 to V_{CC} | V |
| I_{out} | 5 | Max. sink current | 20 | mA |
| V_{LD} | 4 | Open-drain voltage | -0.3 to V_{CC} | V |
| I_{LD} | 4 | Max. sink current | 15 | mA |
| I_{sense} | 1 | Analog input | -0.3 to V_{CC} | V |
| V_{ctrl} | 3 | Analog input | -0.3 to $V_{CC} < 12^{(1)}$ | V |

1. V_{ctrl} cannot exceed V_{CC} and cannot exceed 12 V.

Table 3. Thermal data

| Symbol | Parameter | Value | Unit |
|-----------------|---|------------|------|
| $R_{th\ j-amb}$ | Thermal resistance, junction-to-ambient | 250 | °C/W |
| T_{jop} | Junction temperature operating range | -40 to 150 | °C |
| T_{stg} | Storage temperature | -55 to 150 | |

Figure 2. Pin configuration

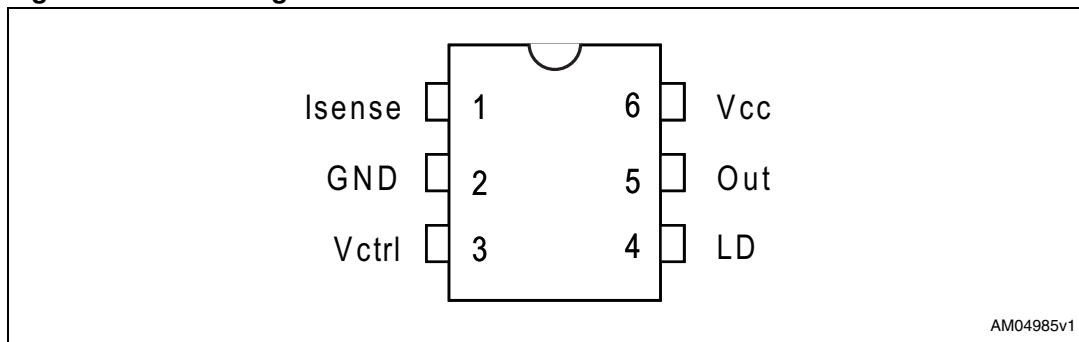

Table 4. Pin functions

| Pin number | Name | Function |
|------------|-------------|--|
| 1 | I_{sense} | Inverting input of the current loop op-amp. The pin is typically used for the current control loop, connecting it to the positive end of the current sense resistor through a decoupling resistor. |
| 2 | GND | Ground. Return of the bias current of the device. 0 V reference for all voltages. The pin has to be tied as close as possible to the ground output terminal of the converter to minimize load current effect on the voltage regulation setpoint. |

Table 4. Pin functions (continued)

| Pin number | Name | Function |
|------------|----------|--|
| 3 | Vctrl | Inverting input of the voltage loop op-amp. The pin is typically used for the voltage control loop and is connected to the midpoint of a resistor divider that senses the output voltage. |
| 4 | LD | Open-drain output able to sink 5 mA (peak), driven by the internal oscillator at 1 kHz square waveform with 12.5% duty cycle. The internal mosfet starts to switch when V_{CC} is above the turn-on threshold (typ. 3 V) and it is off (LD high impedance) when V_{CC} is below the UVLO of the IC. The pin can be connected to an external LED pilot-lamp with a resistor in series in order to limit the LED current |
| 5 | OUT | Common open-drain output of the two internal op-amps. The pin, only able to sink current, is typically connected to the branch of the optocoupler's photodiode to transmit the error signal to the primary side. |
| 6 | V_{CC} | Supply voltage of the device. A small bypass capacitor (0.1 μ F typ.) to GND, located as close to the IC pins as possible, might be useful to get a clean supply voltage. |

Table 5. Electrical characteristics ($-25\text{ }^{\circ}\text{C} < T_j < 125\text{ }^{\circ}\text{C}$, $V_{CC} = 20\text{ V}$; unless otherwise specified)

| Symbol | Parameter | Test condition | Min. | Typ. | Max. | Unit |
|------------------------------------|--|------------------------------------|-------|------|-------|---------------|
| Device supply | | | | | | |
| V_{CC} | Voltage operating range | | 3.5 | | 36 | V |
| I_{CC} | Quiescent current ($I_{ctrl} = V_{sense} = 0$, $OUT = open$) | | | 250 | 500 | μA |
| Voltage control loop op-amp | | | | | | |
| G_{m_v} | Transconductance (sink current only) ⁽¹⁾ | | 1 | 3.5 | | S |
| V_{ctrl} | Voltage reference default value ⁽²⁾ | $T_j = 25\text{ }^{\circ}\text{C}$ | 2.488 | 2.5 | 2.512 | V |
| I_{bias} | Inverting input bias current | | | 25 | | nA |
| Current control loop | | | | | | |
| G_{m_i} | Transconductance (sink current only) ⁽³⁾ | | 1.5 | 7 | | S |
| V_{csth} | Current sense threshold at $I(lout) = 1\text{ mA}$ ⁽⁴⁾ | | 48 | 50 | 52 | mV |
| I_{bias} | Non-inverting input source current | | | 6 | | μA |
| Output stage | | | | | | |
| V_{OUTlow} | Low output level at 2 mA sink current | | | 200 | 400 | mV |
| LED driver | | | | | | |
| I_{LD} | LED driver sink current capability (peak) | | 10 | | | mA |
| f_{LD} | LED driver current modulation frequency | | 0.6 | 1 | 1.4 | kHz |
| V_{LDlow} | Low output level at 5 mA sink current (internal mosfet on) | | | 450 | 900 | mV |
| I_{LD_LKG} | LED driver leakage current (internal mosfet off) | | | | 0.5 | μA |

1. If the voltage on V_{ctrl} (the negative input of the amplifier) is higher than the positive amplifier input, and it is increased by 1mV, the sinking current at the output OUT will be increased by 3.5 mA.
2. The internal voltage reference is set at 2.5 V. The voltage control loop precision takes into account the cumulative effects of the internal voltage reference deviation as well as the input offset voltage of the transconductance operational amplifier. The internal voltage reference is fixed by bandgap, and trimmed to 0.48 % accuracy at room temperature.
3. When the inverting input at I_{sense} is greater than 50 mV, and the voltage is increased by 1 mV, the sinking current at the output Out will be increased by 7 mA.
4. The internal current sense threshold is triggered when the voltage on pin I_{sense} is 50 mV. The current control loop precision takes into account the cumulative effects of the internal voltage reference deviation as well as the input offset voltage of the transconductance operational amplifier.

2 Application information

Figure 3. Typical application schematic

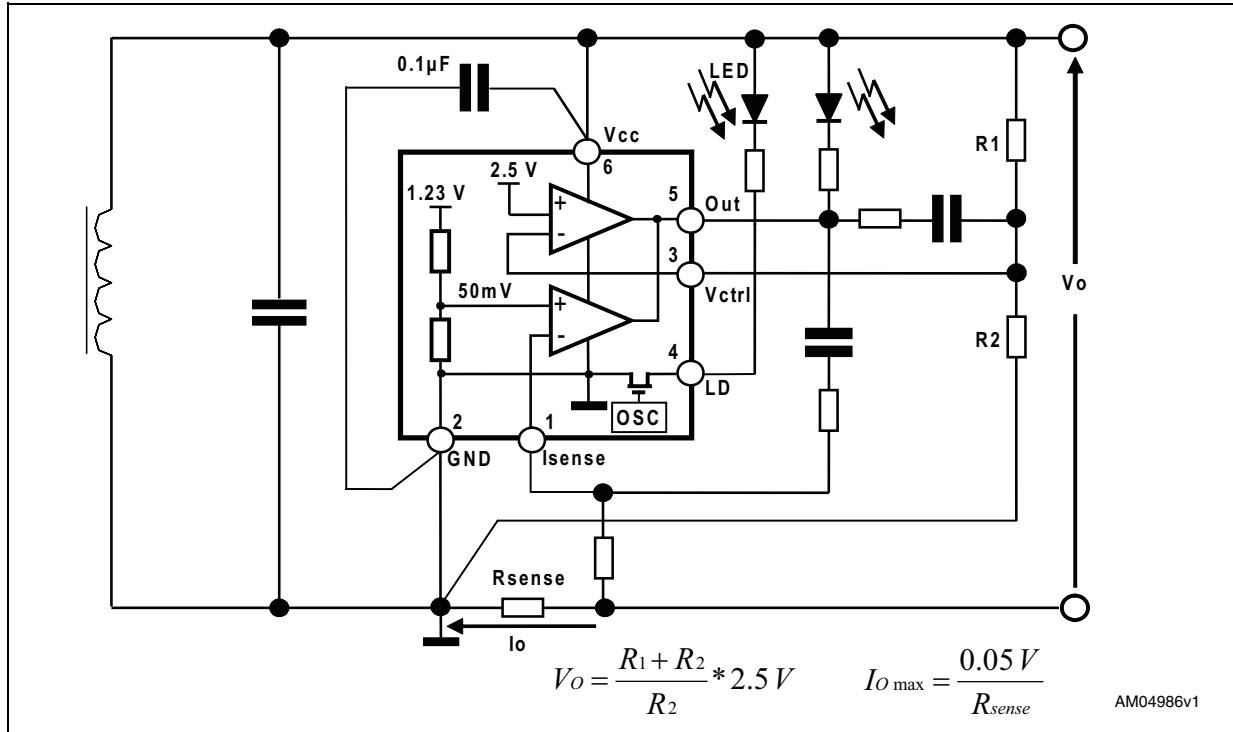

2.1 Voltage and current control

Voltage control

The voltage loop is controlled via a transconductance operational amplifier, the voltage divider R_1 , R_2 , and the optocoupler which is directly connected to the output. It is possible to choose the values of R_1 and R_2 resistors using [Equation 1](#) and [Equation 2](#):

Equation 1

$$V_O = V_{ctrl} * \frac{(R_1 + R_2)}{R_2}$$

Equation 2

$$R_1 = R_2 * \frac{(V_O + V_{ctrl})}{V_{ctrl}}$$

where V_O is the desired output voltage.

As an example, with $R_1 = 100\text{ k}\Omega$ and $R_2 = 15\text{ k}\Omega$ $V_O = 19.17\text{ V}$.

Current control

The current loop is controlled via a transconductance operational amplifier, the sense resistor R_{sense} , and the optocoupler.

The control equation verifies:

Equation 3

$$R_{sense} * I_{Omax} = V_{csth}$$

Equation 4

$$R_{sense} = \frac{V_{csth}}{I_{Omax}}$$

where I_{Omax} is the desired limited current, and V_{csth} is the threshold voltage for the current control loop. As an example, with $I_{Omax} = 1$ A, $V_{csth} = 50$ mV, then $R_{sense} = 50$ m Ω .

Note that the R_{sense} resistor should be chosen, taking into account the maximum dissipation (P_{lim}) through it during full load operation.

Equation 5

$$P_{lim} = V_{csth} * I_{Omax}$$

As an example, with $I_{Omax} = 1$ A and $V_{csth} = 50$ mV, $P_{lim} = 50$ mW.

Therefore, for most adaptor and battery charger applications, a low-power resistor is suitable for the current sensing function.

V_{csth} threshold is achieved internally by a voltage divider tied to an internal precise voltage reference. Its midpoint is tied to the positive input of the current control operational amplifier, and its endpoint is connected to GND. The resistors of this voltage divider are matched to provide the best precision possible. The current sinking outputs of the two transconductance operational amplifiers are common (to the output of the IC). This makes an OR function which ensures that whenever the current or the voltage reaches excessively high values, the optocoupler is activated.

The relationship between the controlled current and the controlled output voltage can be described with a square characteristic as shown in the following V/I output-power graph (with power supply of the device independent from the output voltage).

Figure 4. Output voltage versus output current

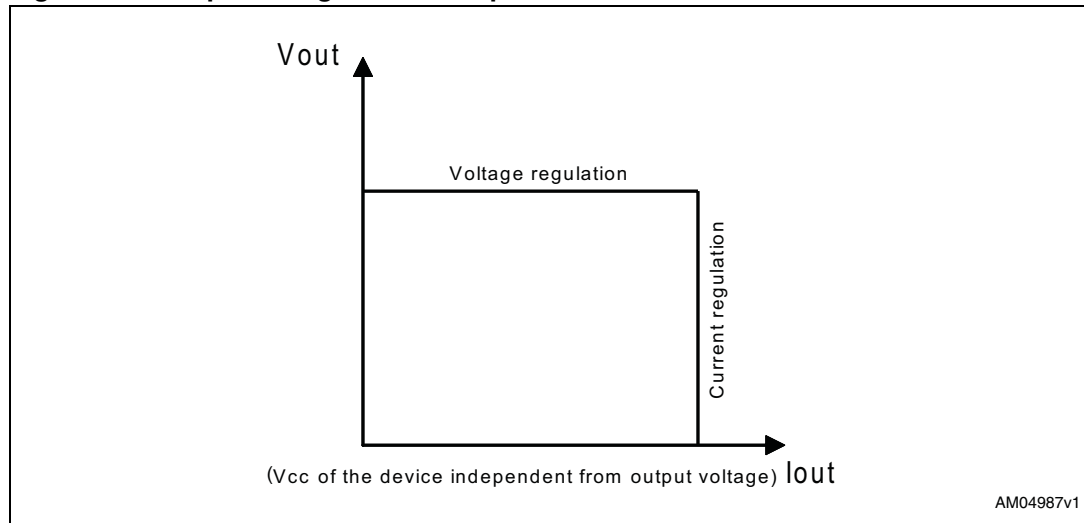

2.2 Compensation

The voltage control transconductance operational amplifier can be fully compensated. Both its output and negative input are directly accessible for external compensation components.

2.3 LD pin function

The device provides a unique feature that allows highly efficient driving of an LED pilot-lamp. The main benefit of this new feature is to allow reducing the standby power consumption of the SMPS with the LED pilot-lamp.

The LD pin is an open-drain output able to sink 5 mA (peak), driven by the internal oscillator at 1 kHz (typ.) square waveform with 12.5% duty cycle (see [Figure 6](#)). The internal mosfet starts to switch when V_{CC} is above the turn-on threshold (typ 3 V) and it is off (LD high impedance) when V_{CC} is below the UVLO of the IC.

Connecting the LED pilot-lamp, with a resistor in series in order to limit the LED current, to pin LD (as shown in [Figure 5](#)) reduces the power consumption of the LED while keeping the same driving peak current. The LED driving current modulation frequency of 1 kHz (typ.) eliminates the visual perception of flickering.

Figure 5. Connection of LED to pin LD

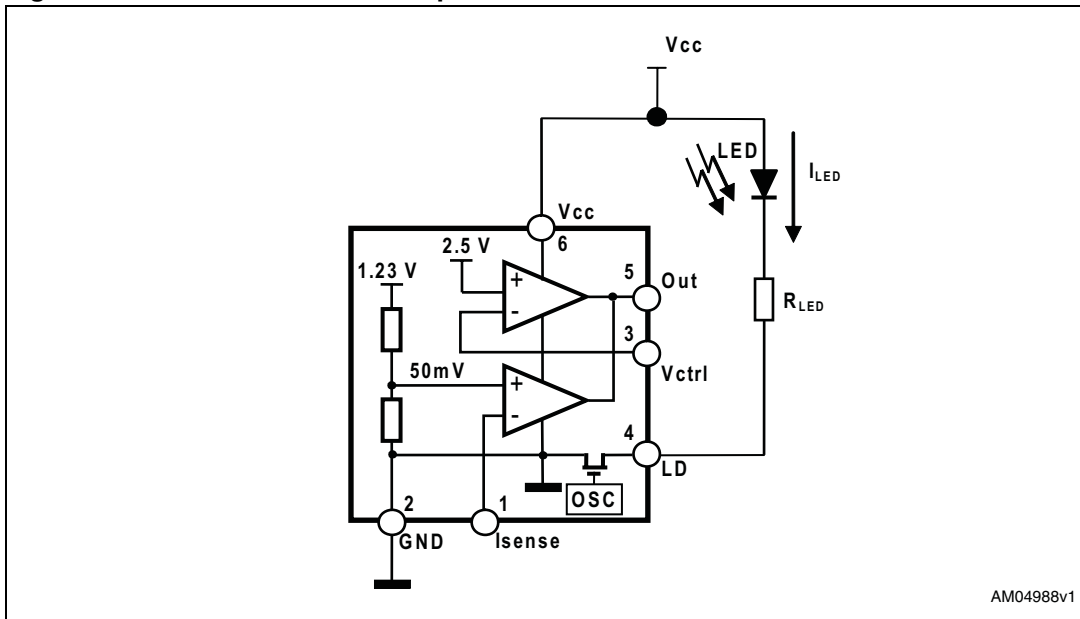
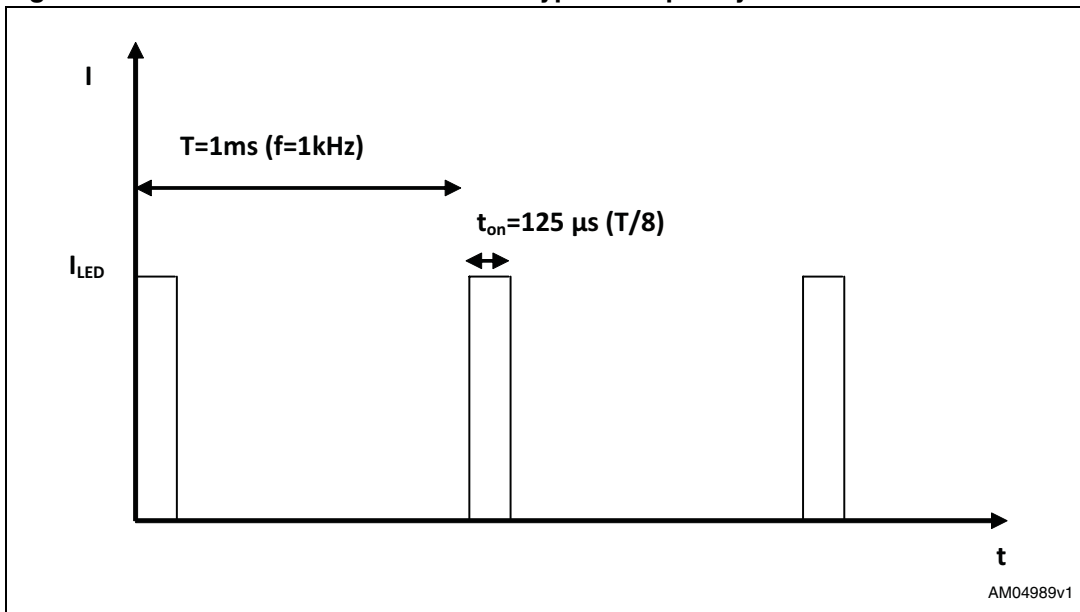

Figure 6. LED current waveform with a typical frequency of 1 kHz



3 Package mechanical data

In order to meet environmental requirements, ST offers these devices in different grades of ECOPACK[®] packages, depending on their level of environmental compliance. ECOPACK[®] specifications, grade definitions and product status are available at: www.st.com. ECOPACK[®] is an ST trademark.

Table 6. SOT23-6L (2.90 mm x 2.80 mm) package mechanical data

| Sym | mm | | | inches | | |
|-----|------|------|------|--------|-------|-------|
| | Min | Typ | Max | Min | Typ | Max |
| A | | | 1.45 | | | 0.057 |
| A1 | 0.00 | | 0.15 | 0.000 | | 0.006 |
| A2 | 0.90 | 1.15 | 1.30 | 0.035 | 0.045 | 0.051 |
| b | 0.30 | | 0.50 | 0.012 | | 0.020 |
| c | 0.08 | | 0.22 | 0.003 | | 0.009 |
| D | | 2.90 | | | 0.114 | |
| E | | 2.80 | | | 0.110 | |
| E1 | | 1.60 | | | 0.063 | |
| e | | 0.95 | | | 0.037 | |
| e1 | | 1.90 | | | 0.075 | |
| L | 0.30 | 0.45 | 0.60 | 0.012 | 0.018 | 0.024 |
| è | 0° | 4° | 8° | 0° | 4° | 8° |
| N | 6 | | | 6 | | |

Note: Dimensions per JEDEC MO178AB

Figure 7. SOT23-6L (2.90 mm x 2.80 mm) package mechanical drawing

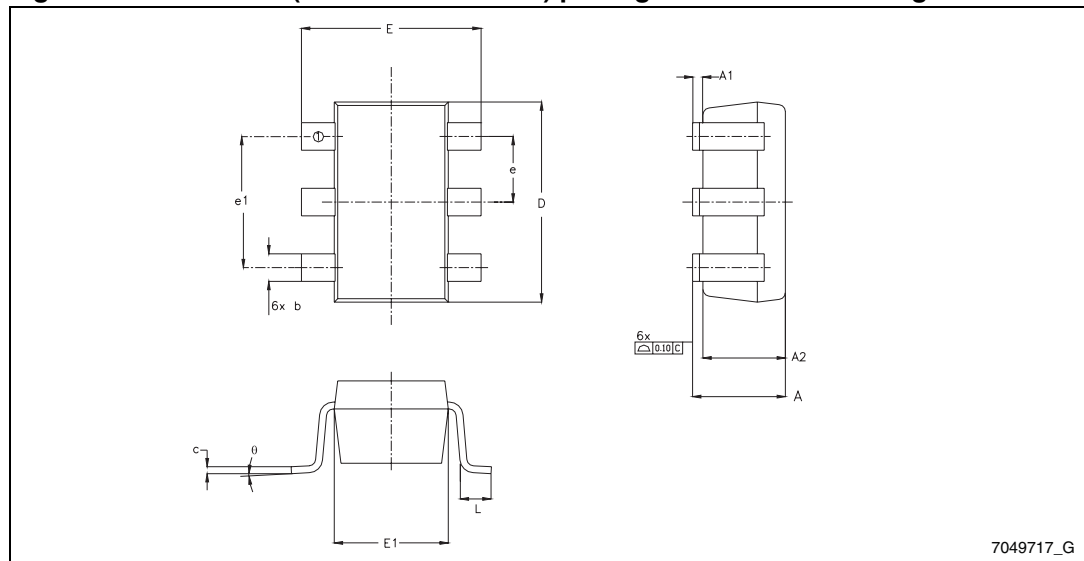

7049717_G

4 Revision history

Table 7. Document revision history

| Date | Revision | Changes |
|-------------|----------|------------------|
| 23-Feb-2011 | 1 | Initial release. |

Please Read Carefully:

Information in this document is provided solely in connection with ST products. STMicroelectronics NV and its subsidiaries ("ST") reserve the right to make changes, corrections, modifications or improvements, to this document, and the products and services described herein at any time, without notice.

All ST products are sold pursuant to ST's terms and conditions of sale.

Purchasers are solely responsible for the choice, selection and use of the ST products and services described herein, and ST assumes no liability whatsoever relating to the choice, selection or use of the ST products and services described herein.

No license, express or implied, by estoppel or otherwise, to any intellectual property rights is granted under this document. If any part of this document refers to any third party products or services it shall not be deemed a license grant by ST for the use of such third party products or services, or any intellectual property contained therein or considered as a warranty covering the use in any manner whatsoever of such third party products or services or any intellectual property contained therein.

UNLESS OTHERWISE SET FORTH IN ST'S TERMS AND CONDITIONS OF SALE ST DISCLAIMS ANY EXPRESS OR IMPLIED WARRANTY WITH RESPECT TO THE USE AND/OR SALE OF ST PRODUCTS INCLUDING WITHOUT LIMITATION IMPLIED WARRANTIES OF MERCHANTABILITY, FITNESS FOR A PARTICULAR PURPOSE (AND THEIR EQUIVALENTS UNDER THE LAWS OF ANY JURISDICTION), OR INFRINGEMENT OF ANY PATENT, COPYRIGHT OR OTHER INTELLECTUAL PROPERTY RIGHT.

UNLESS EXPRESSLY APPROVED IN WRITING BY AN AUTHORIZED ST REPRESENTATIVE, ST PRODUCTS ARE NOT RECOMMENDED, AUTHORIZED OR WARRANTED FOR USE IN MILITARY, AIR CRAFT, SPACE, LIFE SAVING, OR LIFE SUSTAINING APPLICATIONS, NOR IN PRODUCTS OR SYSTEMS WHERE FAILURE OR MALFUNCTION MAY RESULT IN PERSONAL INJURY, DEATH, OR SEVERE PROPERTY OR ENVIRONMENTAL DAMAGE. ST PRODUCTS WHICH ARE NOT SPECIFIED AS "AUTOMOTIVE GRADE" MAY ONLY BE USED IN AUTOMOTIVE APPLICATIONS AT USER'S OWN RISK.

Resale of ST products with provisions different from the statements and/or technical features set forth in this document shall immediately void any warranty granted by ST for the ST product or service described herein and shall not create or extend in any manner whatsoever, any liability of ST.

ST and the ST logo are trademarks or registered trademarks of ST in various countries.

Information in this document supersedes and replaces all information previously supplied.

The ST logo is a registered trademark of STMicroelectronics. All other names are the property of their respective owners.

© 2011 STMicroelectronics - All rights reserved

STMicroelectronics group of companies

Australia - Belgium - Brazil - Canada - China - Czech Republic - Finland - France - Germany - Hong Kong - India - Israel - Italy - Japan - Malaysia - Malta - Morocco - Philippines - Singapore - Spain - Sweden - Switzerland - United Kingdom - United States of America

www.st.com

Данный компонент на территории Российской Федерации

Вы можете приобрести в компании MosChip.

Для оперативного оформления запроса Вам необходимо перейти по данной ссылке:

<http://moschip.ru/get-element>

Вы можете разместить у нас заказ для любого Вашего проекта, будь то серийное производство или разработка единичного прибора.

В нашем ассортименте представлены ведущие мировые производители активных и пассивных электронных компонентов.

Нашей специализацией является поставка электронной компонентной базы двойного назначения, продукции таких производителей как XILINX, Intel (ex.ALTERA), Vicor, Microchip, Texas Instruments, Analog Devices, Mini-Circuits, Amphenol, Glenair.

Сотрудничество с глобальными дистрибьюторами электронных компонентов, предоставляет возможность заказывать и получать с международных складов практически любой перечень компонентов в оптимальные для Вас сроки.

На всех этапах разработки и производства наши партнеры могут получить квалифицированную поддержку опытных инженеров.

Система менеджмента качества компании отвечает требованиям в соответствии с ГОСТ Р ИСО 9001, ГОСТ РВ 0015-002 и ЭС РД 009

Офис по работе с юридическими лицами:

105318, г.Москва, ул.Щербаковская д.3, офис 1107, 1118, ДЦ «Щербаковский»

Телефон: +7 495 668-12-70 (многоканальный)

Факс: +7 495 668-12-70 (доб.304)

E-mail: info@moschip.ru

Skype отдела продаж:

moschip.ru

moschip.ru_4

moschip.ru_6

moschip.ru_9