

NEW

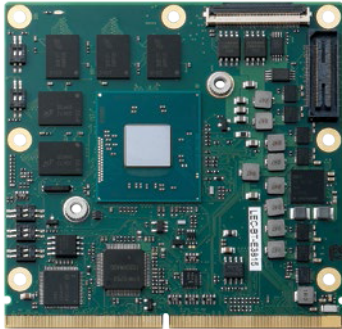

SMARC

*LEC = Low Energy Computer-on-Module

Features

- Single, dual or quad-core Intel® Atom™ Processor E3800 Series System-on-Chip
- Up to 8 GB DDR3L at 1066/1333 MHz (ECC)
- HDMI and LVDS, onboard eMMC
- GbE, camera interface
- 1x SATA 3Gb/s, 1x USB 3.0, 3x USB 2.0, max. 12x GPIO
- Extreme Rugged™ operating temperature: -40°C to 85°C

Specifications

Core System

CPU	Intel® Atom™ E3800 Series, single, dual or quad-core SoC with integrated graphics Atom™ E3845 (4C/1333), 1.91 GHz, Gfx 542/792 MHz (Turbo), 10 W TDP Atom™ E3826 (2C/1066), 1.46 GHz, Gfx 533/667 MHz (Turbo), 7 W TDP Atom™ E3815 (1C/1066), 1.46 GHz, Gfx 400/- MHz (No Turbo), 5 W TDP Atom™ E3805 (2C/1066), 1.33 GHz (No GFX) 3W TDP
-----	---

Memory	Up to 8 GB DDR3L at 1066/1333 MHz, memory down with ECC
--------	---

Alignment	AMI UEFI with CMOS backup in 8 MB SPI BIOS, Fast Boot support
-----------	---

Cache	512 kB to 2 MB L2 cache
-------	-------------------------

SEMA Board Controller	Supports: Voltage/Current monitoring, Power Sequencing, Logistics and Forensic Information, Flat Panel Control, I ² C Bus Control, GPIO Control, User Flash, Failsafe BIOS (dual BIOS), Watchdog Timer and Fan Control
-----------------------	---

Video

GPU Feature Support	7th generation Intel® graphics core architecture with four execution units, supports two independent displays 2D and 3D graphics hardware acceleration Support for DirectX 11.1, OGL ES 2.0, OGL 3.2 Video decode HW acceleration for H.264, MPEG2, VC1, VP8 formats Video encode HW acceleration for H.264, MPEG2 formats
---------------------	--

LVDS	Single channel 18/24-bit LVDS from DDI0
------	---

HDMI	HDMI 1.4a from DDI1
------	---------------------

Audio

Chipset	Intel® HD Audio integrated in SOC
Ports	I ² S and HDA for audio codec on carrier

Ethernet

Intel® MAC/PHY Interface	1x Intel® i210IT Ethernet controller 10/100/1000 GbE
--------------------------	---

I/O Interfaces

PCIe	3x PCIe x1 Gen2
USB	1x USB 3.0 + 3x USB 2.0
SATA	1x SATA 3 Gb/s
eMMC	Soldered, bootable eMMC flash storage from 4 to 64 GB (optional)
SDIO	1x SDIO (4-bit)
GPIO	12x GPIO, 5x used for camera, 7x available
Camera	CSI 4L/1L
Serial	2x SPI, 2x I ² C, 1x I ² S, Power Management, 2x UART

Power

Standard Input	3.0 V ~ 5.25 V DC ±5%
Power States	Supports C0-C6, S0, S3, S4, S5

Mechanical and Environmental

Form Factor	SMARC Specification v1.1
Dimensions	SMARC full size module, 82 mm x 80 mm
Operating Temperature	Standard: 0°C to +60°C Extreme Rugged™: -40°C to +85°C
Humidity	5-90% RH operating, non-condensing 5-95% RH storage (and operating with conformal coating)
Shock and Vibration	IEC 60068-2-64 and IEC-60068-2-27 MIL-STD-202F, Method 213B, Table 213-I, Condition A and Method 214A, Table 214-I, Condition D
HALT	Thermal Stress, Vibration Stress, Thermal Shock and Combined Test

Operating Systems

Standard Support	Linux, VxWorks, Windows 7/8, Windows Embedded Compact 7
Extended Support (BSP)	QNX, Android

Functional Diagram

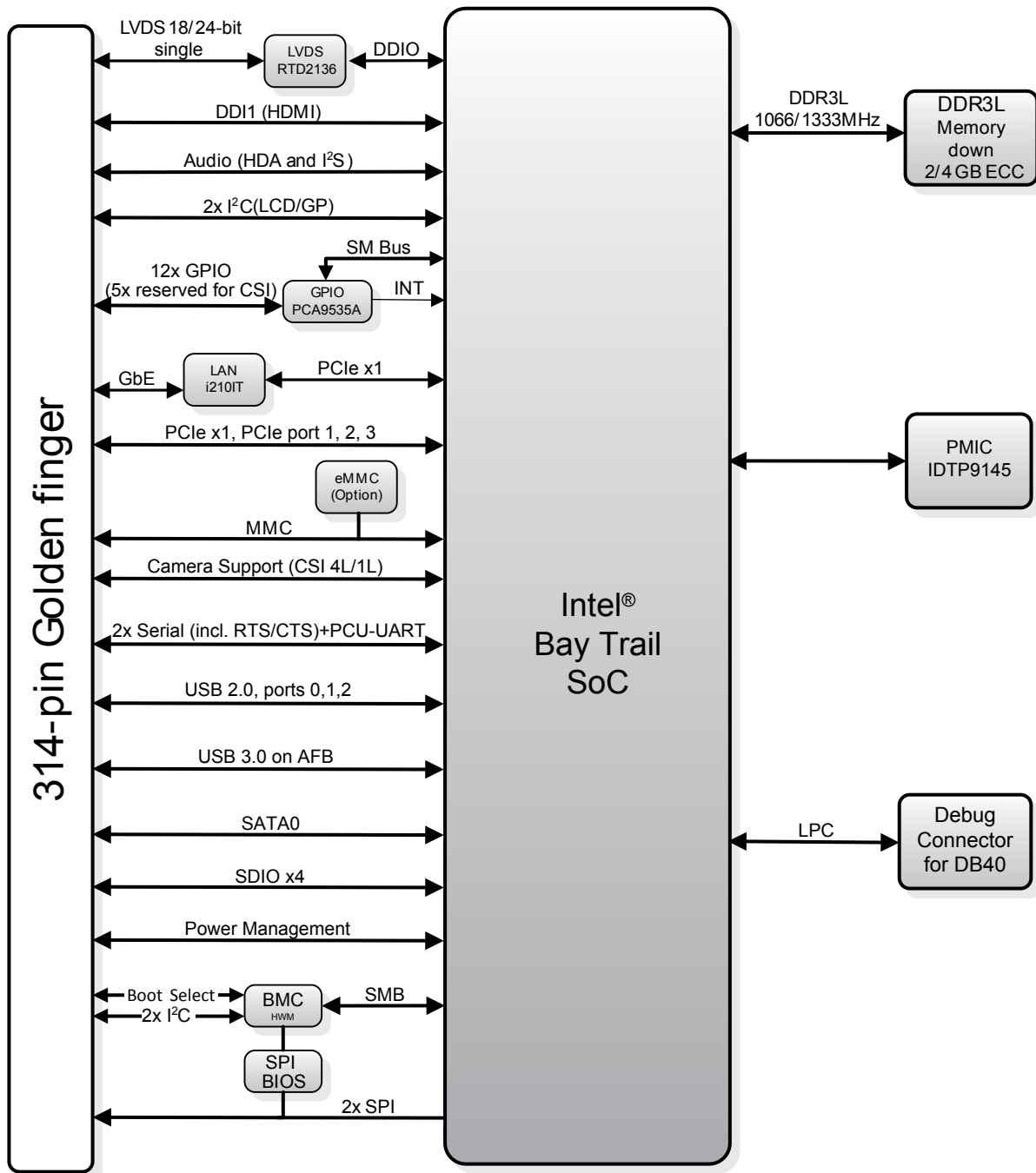

Ordering Information

Modules

Model Number	Description/Configuration
LEC-BT4-4G-8G-ER	SMARC® Full Size Module with Intel® Atom™ E3845, quad core, 4 GB DDR3L, 8 GB eMMC, Extreme Rugged™ operating temperature: -40°C to +85°C
LEC-BT2-2G-8G-ER	SMARC® Full Size Module with Intel® Atom™ E3826, dual core, 2 GB DDR3L, 8 GB eMMC, Extreme Rugged™ operating temperature: -40°C to +85°C

LEC-BT1-2G-8G-ER	SMARC® Full Size Module with Intel® Atom™ E3815, single core, 2 GB DDR3L, 8 GB eMMC, Extreme Rugged™ operating temperature: -40°C to +85°C
LEC-BT-HS	Heatspreader for LEC-BTS

Данный компонент на территории Российской Федерации

Вы можете приобрести в компании MosChip.

Для оперативного оформления запроса Вам необходимо перейти по данной ссылке:

<http://moschip.ru/get-element>

Вы можете разместить у нас заказ для любого Вашего проекта, будь то серийное производство или разработка единичного прибора.

В нашем ассортименте представлены ведущие мировые производители активных и пассивных электронных компонентов.

Нашей специализацией является поставка электронной компонентной базы двойного назначения, продукции таких производителей как XILINX, Intel (ex.ALTERA), Vicor, Microchip, Texas Instruments, Analog Devices, Mini-Circuits, Amphenol, Glenair.

Сотрудничество с глобальными дистрибьюторами электронных компонентов, предоставляет возможность заказывать и получать с международных складов практически любой перечень компонентов в оптимальные для Вас сроки.

На всех этапах разработки и производства наши партнеры могут получить квалифицированную поддержку опытных инженеров.

Система менеджмента качества компании отвечает требованиям в соответствии с ГОСТ Р ИСО 9001, ГОСТ РВ 0015-002 и ЭС РД 009

Офис по работе с юридическими лицами:

105318, г.Москва, ул.Щербаковская д.3, офис 1107, 1118, ДЦ «Щербаковский»

Телефон: +7 495 668-12-70 (многоканальный)

Факс: +7 495 668-12-70 (доб.304)

E-mail: info@moschip.ru

Skype отдела продаж:

moschip.ru

moschip.ru_4

moschip.ru_6

moschip.ru_9