

LED Drivers for LCD Backlights

White LED Driver for large LCD panel



BD9422EFV

●General Description

BD9422EFV is a high efficiency driver for white LEDs and designed for large LCD panel. This IC is built-in high current drive and high responsibility type 6ch LED drivers and 1ch boost DCDC converter. BD9422EFV has some protect function against fault conditions, such as the over-voltage protection (OVP), LED OPEN and SHORT protection, the over current limit protection of DCDC (OCP). Therefore BD9422EFV is available for the fail-safe design over a wide range output voltage.

●Key Specification

- Operating power supply voltage range: 9.0V to 35.0V
- Oscillator frequency: 500kHz (RT=30kΩ)
- Operating Current: 9mA (typ.)
- Operating temperature range: -40°C to +85°C

●Applications

TV, Computer Display, Notebook, LCD Backlighting

●Typical Application Circuit

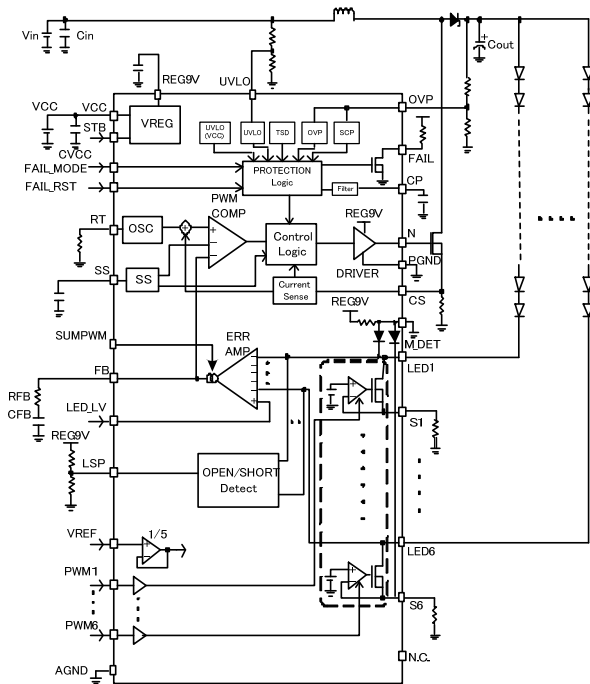

Figure 1. Typical Application Circuit

●Features

- 6ch Constant LED drivers, available 400mA drive per 1ch.
- Constant current accuracy ±1.8% (IC only)
- Each 6ch external PWM inputs can control independent dimming .
- Current analog (linear) dimming by VREF
- 1ch boost controller with current mode (external FET)
- Several protection functions
DCDC part : OCP/OVP/UVLO/TSD
LED driver part : OPEN,SHORT detection
- SHORT detection voltage is set by LSP terminal.
Error detection output FAIL terminal inside (normal=Open, error=Drain)
- Master/Slave mode inside

●Package

	W(Typ.)	D(Typ.)	H(Max.)
HTSSOP-B40	13.60mm	7.80mm	1.00mm
Pin Pitch:			0.65mm

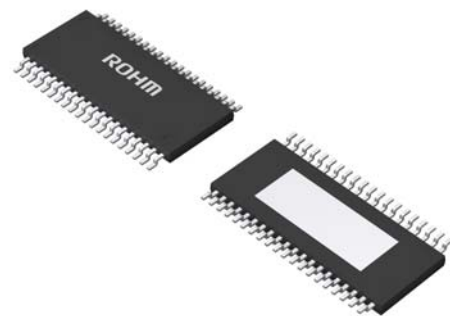

Figure 2. HTSSOP-B40

•1.1 Electrical Characteristics 1(Unless otherwise specified, Ta=25°C, VCC=24V)

Parameter	Symbol	Limit			Unit	Condition
		Min.	Typ.	Max.		
【Whole device】						
Operating circuit current	ICC	-	9	16	mA	STB=3V,LED1-6=ON, RT=30kΩ
Stand-by circuit current	ISTB	-	12	20	μA	STB=0V
【REG9V block】						
REG9V output voltage	REG9V	8.9	9.0	9.1	V	IO=0mA
Maximum REG9V output current	IREG9V	20	-	-	mA	
【Switching block】						
N terminal source resistance	RONH	-	2.5	3.5	Ω	ION=-10mA
N terminal sink resistance	RONL	-	3.0	4.2	Ω	ION=10mA
【Over current protection (OCP) block】						
Over current protection voltage	VOCP	0.40	0.45	0.50	V	VCS=SWEEP UP
【Soft-start block】						
SS terminal source current	ISS	-1.4	-1.0	-0.6	μA	
SS terminal release voltage	VSS	2.9	3.0	3.1	V	SS=SWEEP UP
【Error amplifier block】						
LED control voltage	VLED	0.66	0.7	0.74	V	LED_LV=0.7V
FB sink current	IFBSINK	55	100	155	μA	LED=2.0V, VFB=1.0V
FB source current (Master)	IFBSOURCEM	-155	-100	-55	μA	LED=0V, VFB=1.0V,CS=0V
FB source current (Slave)	IFBSWRCKS	-310	-200	-110	μA	LED=0V,VFB=1.0V,CS=5V
LED_LV terminal input current	ILED_LV	-2	0	2	uA	VLED_LV=3V
【CT oscillator block】						
Oscillation frequency	FCT	440	500	560	kHz	RT=30kΩ
MAX DUTY	DMAX	83	89	96	%	
【Over voltage protection (OVP) block】						
OVP detection voltage	VOVP	2.34	2.43	2.52	V	VOVP=SWEEP UP
OVP hysteresis voltage	VOVPHYS	10	50	100	mV	VOVP=SWEEP DOWN
OVP feedback voltage	FBOVP	0.93	1.05	1.17	V	PMW1-6=0V,SS=2.8V, VLED_LV=0.7V
【Short current protection (SCP) block】						
Short circuit protection voltage	VSCP	0.12	0.20	0.28	V	VOVP=SWEEP DOWN
【M_LED block】						
Diode forward voltage	VFLED	1120	1340	1560	mV	VLED=0V
Forward voltage offset each ch	VFOFFSET	-	-	20	mV	VLED=0V
REG9V pull up resistance	RM_DET	60	100	140	kΩ	

•1.2 Electrical Characteristics 2(Unless otherwise specified, Ta=25°C, VCC=24V)

Parameter	Symbol	Limit			Unit	Condition
		Min.	Typ.	Max.		
【UVLO block】						
Operation power source voltage (VCC)	VUVLO_VCC	7.0	7.5	8.0	V	VCC=SWEEP UP
Hysteresis voltage (VCC)	VUHYS_VCC	150	300	600	mV	VCC=SWEEP DOWN
UVLO Release voltage	VUVLO_U	2.40	2.50	2.60	V	VUVLO=SWEEP UP
UVLO detection voltage	VUVLOD_U	2.15	2.30	2.45	V	VUVLO=SWEEP DOWN
UVLO terminal input resistance	RUVLO	395	610	825	kΩ	VUVLO=3V
【Filter block】						
CP detection voltage	VCP	1.9	2.0	2.1	V	CP=SWEEP UP
CP source current	ICP	-1.2	-1.0	-0.8	μA	VCP=0V
【LED driver block】						
S terminal voltage	VSLED	196	200	204	mV	VREF=1.0V
		294.6	300	305.4	mV	VREF=1.5V
		392.8	400	407.2	mV	VREF=2.0V
		491	500	509	mV	VREF=2.5V
LED current rise time	ILEDtr	-	400	760	ns	VREF=0.3V,RS=2Ω
LED current fall time	ILEDtf	-	100	280	ns	VREF=0.3V,RS=2Ω
OPEN detection voltage	VOPEN	0.12	0.20	0.28	V	VLED=SWEEP DOWN
SHORT detection voltage	VSHORT	5.7	6.0	6.3	V	VLED=SWEEPUP, VLSP=1.2V
SHORT MASK voltage	VSHTMASK	2.85	3.0	3.15	V	
VREF terminal input current	IVREF	-2	0	2	μA	VVREF=3V
LSP terminal input current	ILSP	-2	0	2	μA	VLSP=3V
【STB block】						
STB terminal HIGH voltage	STBH	2.0	-	VCC	V	
STB terminal LOW voltage	STBL	-0.3	-	0.8	V	
STB terminal Pull Down resistance	RSTB	0.5	1.0	1.5	MΩ	STB=3V
【PWM IN block】						
PWM terminal HIGH voltage	PWMH	2.0	-	20	V	
PWM terminal LOW voltage	PWML	-0.3	-	0.8	V	
PWM terminal Pull Down resistance	RPWM	200	300	400	kΩ	PWM=3V
【FAIL_MODE,FAIL_RST,SUMPWM block】						
Input terminal High voltage	VINH	2.0	-	20	V	
Input terminal Low voltage	VINL	-0.3	-	0.8	V	
Input terminal Pull Down resistance	RVIN	60	100	140	kΩ	VIN=3V
【FAIL block (OPEN DRAIN)】						
FAIL LOW output voltage	VOL	0.25	0.5	1.0	V	IOL=1mA

●1.3 Pin Descriptions

No	Pin name	In/Out	Function	rating [V]
1	VCC	IN	Power source terminal	-0.3 to 36
2	FAIL	OUT	Abnormality detection output terminal (OPEN DRAIN)	-0.3 to 36
3	REG9V	OUT	9V regulator output terminal	-0.3 to 13
4	N.C.	-	Non connection terminal	-
5	N	OUT	DC/DC switching output terminal	-0.3 to 13
6	PGND	IN	Power GND terminal	-
7	CS	IN	DC/DC FET output current detection terminal	-0.3 to 7
8	OVP	IN	Overvoltage protection detection terminal	-0.3 to 7
9	M_DET	OUT	LED Diode OR output terminal	-0.3 to 13
10	SUMPWM	IN/OUT	PWM signal enable/disable detection terminal	-0.3 to 7
11	LED1	OUT	LED output 1	-0.3 to 60
12	LED2	OUT	LED output 2	-0.3 to 60
13	LED3	OUT	LED output 3	-0.3 to 60
14	LED4	OUT	LED output 4	-0.3 to 60
15	LED5	OUT	LED output 5	-0.3 to 60
16	LED6	OUT	LED output 6	-0.3 to 60
17	STB	IN	Standby control terminal	-0.3 to 36
18	PWM1	IN	PWM dimming input signal terminal for LED 1	-0.3 to 22
19	PWM2	IN	PWM dimming input signal terminal for LED 2	-0.3 to 22
20	PWM3	IN	PWM dimming input signal terminal for LED 3	-0.3 to 22
21	PWM4	IN	PWM dimming input signal terminal for LED 4	-0.3 to 22
22	PWM5	IN	PWM dimming input signal terminal for LED 5	-0.3 to 22
23	PWM6	IN	PWM dimming input signal terminal for LED 6	-0.3 to 22
24	FAIL_RST	IN	FAIL output reset terminal	-0.3 to 22
25	S6	IN	Connecting terminal for LED 6 constant current setting resistor	-0.3 to 7
26	S5	IN	Connecting terminal for LED 5 constant current setting resistor	-0.3 to 7
27	S4	IN	Connecting terminal for LED 4 constant current setting resistor	-0.3 to 7
28	S3	IN	Connecting terminal for LED 3 constant current setting resistor	-0.3 to 7
29	S2	IN	Connecting terminal for LED 2 constant current setting resistor	-0.3 to 7
30	S1	IN	Connecting terminal for LED 1 constant current setting resistor	-0.3 to 7
31	CP	OUT	Connecting terminal for non-reaction time setting capacitor	-0.3 to 7
32	SS	OUT	Connecting terminal for soft-start time setting capacitor	-0.3 to 7
33	FB	OUT	Error amplifier output terminal	-0.3 to 7
34	RT	OUT	Connecting terminal for DC/DC frequency setting resistor	-0.3 to 7
35	VREF	IN	Analog dimming DC voltage input terminal	-0.3 to 7
36	LED_LV	IN	LED control voltage set terminal	-0.3 to 7
37	LSP	IN	LED SHORT detection voltage setting terminal	-0.3 to 7
38	FAIL_MODE	IN	FAIL function change terminal	-0.3 to 7
39	UVLO	IN	Low voltage malfunction prevention detection terminal	-0.3 to 10.5
40	AGND	IN	GND terminal for analog part	-

•1.4.1 I/O equivalence circuit

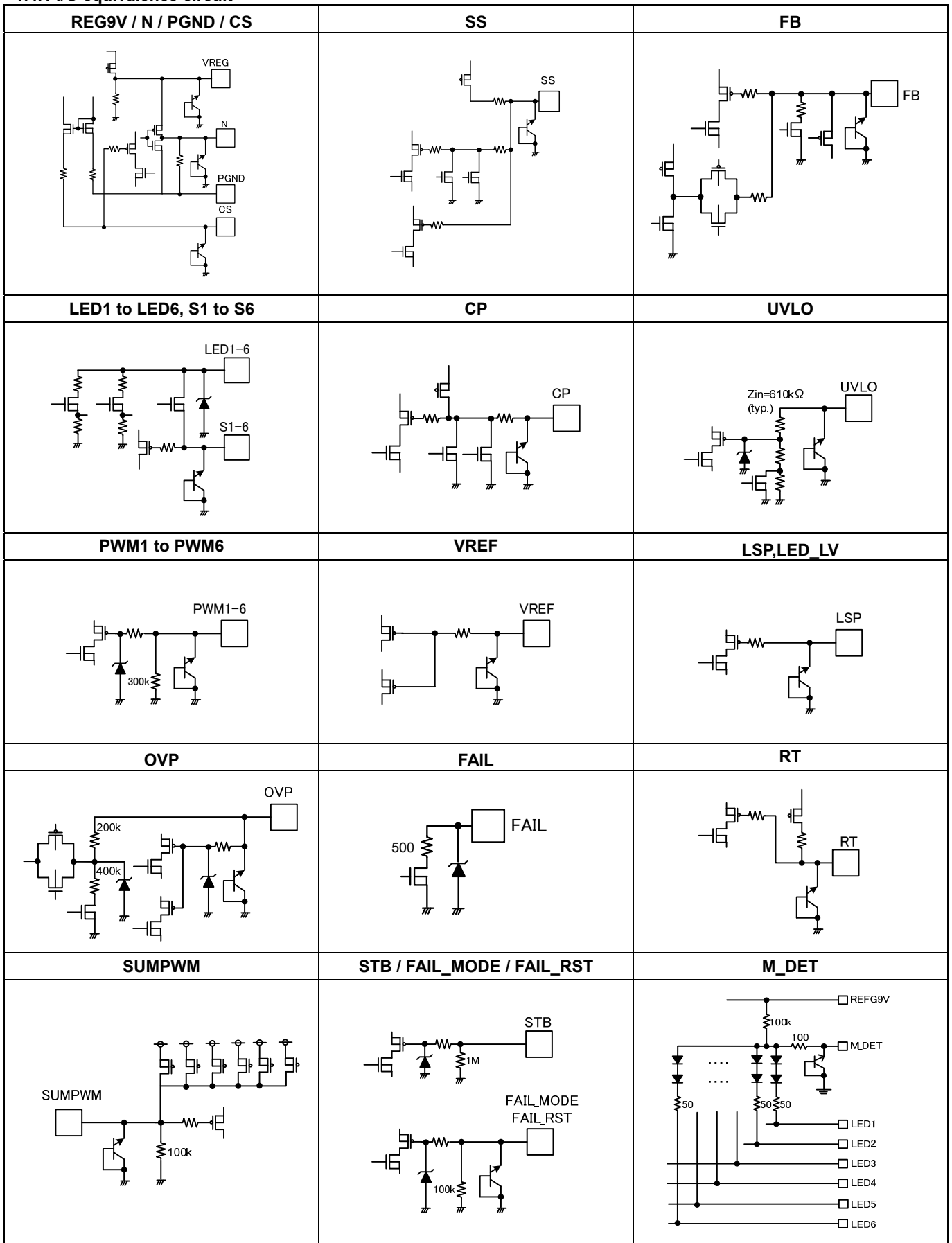

Figure 5. I/O equivalence circuit

•1.5 Typical Performance Curves (reference data)

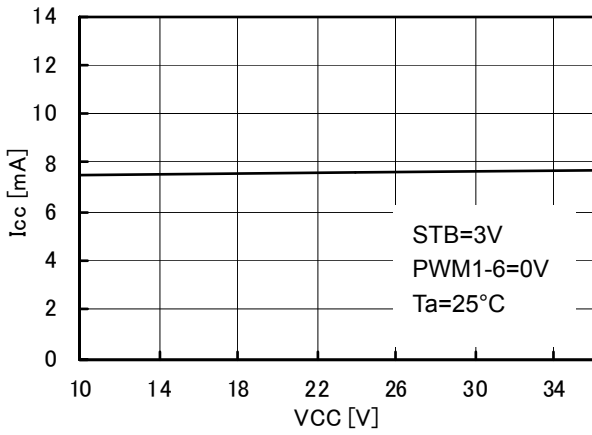

Figure 6. Circuit current

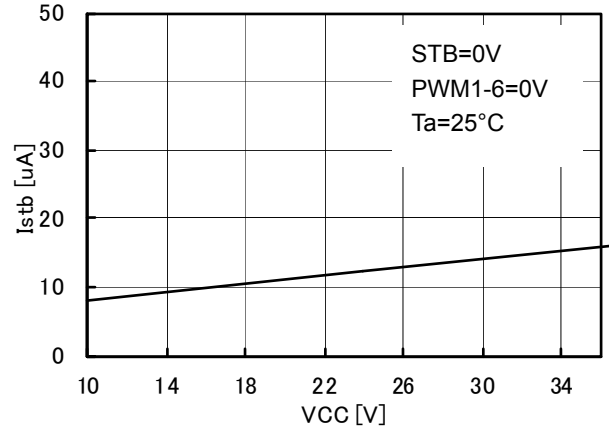

Figure 7. Stand-by circuit current

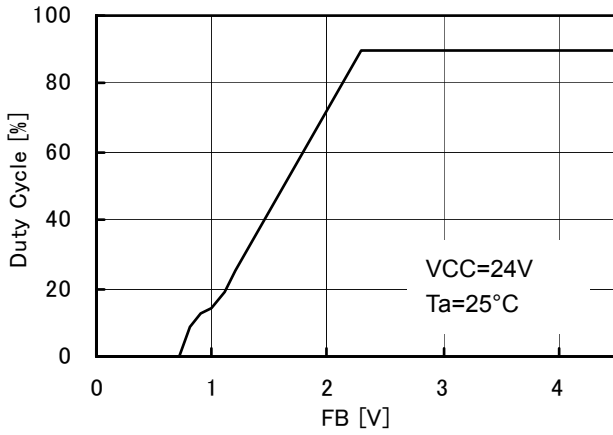

Figure 8. FB v.s. Duty Cycle

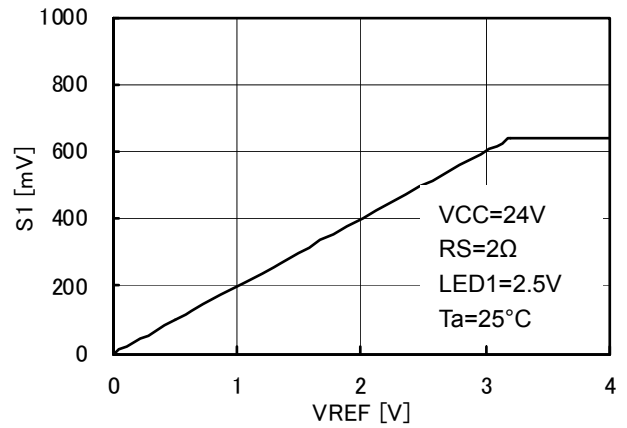

Figure 9. VREF v.s. Sx

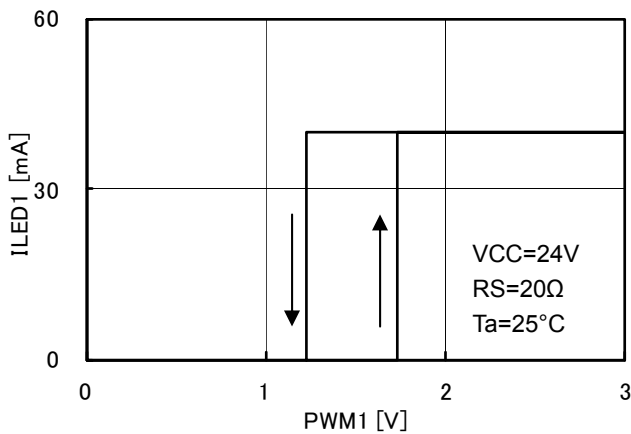

Figure 10. PWM terminal threshold voltage

•2 Block Diagram

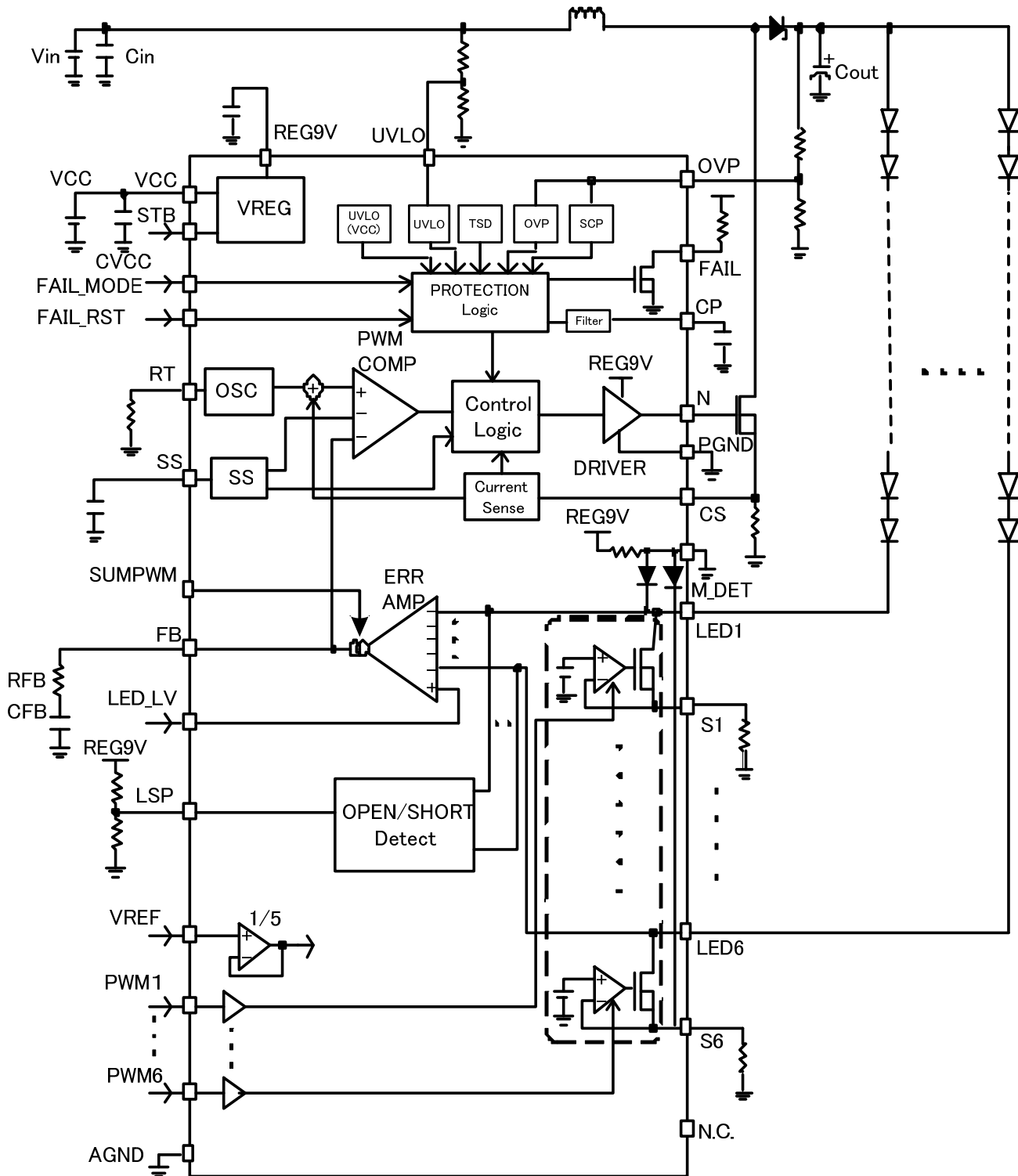

Figure 11. Block Diagram

●3.1 Pin Configuration

1 pin. VCC

Power supply terminal of IC. The input range is 9 to 35V.
The operation starts over VCC=7.5V(typ.) and the system stops under VCC=7.2V(typ.).

2 pin. FAIL

FAIL signal output terminal (NMOS open-drain). NMOS is OPEN at the normal operation so FAIL pin is Hi-Z. NMOS becomes ON state (500 ohm typ.) at the abnormal detection. It is possible to select the FAIL type from latch type (FAIL_MODE=L) or one shot pulse (FAIL_MODE=H). Please refer to the detail explanation <38pin. FAIL_MODE terminal>

3 pin. REG9V

REG9V is a 9 V output pin used delivering 20mA at maximum for switching power supply of N terminal. Use at a current higher than 20mA may affect the reference voltage within IC, which may result in malfunction. It will also cause heating of IC itself. Therefore it is recommended to set the load as small as possible.

The characteristic of VCC line regulation at REG9V is shown as figure. VCC must be used in more than 10.5V for stable 9V output.

Install an oscillation prevention ceramic capacitor (2.2 to 10 μ F) nearest to VREG between VREG-AGND terminals.

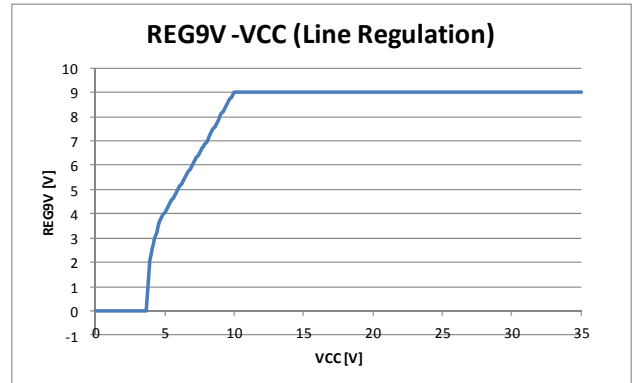

Figure 12.

4 pin. N.C

Non connect pin. Please set it the open state or deal with connecting the GND.

5 pin. N

Gate driving output pin of external NMOS of DC/DC converter with 0 to 9V (REG9V) swing. Output resistance of High side is 2.5 ohm(typ.), Low side is 3.0 ohm(typ.) in ON state. The oscillation frequency is set by a resistance connected to RT pin. For details, see the explanation of <34pin. RT terminal>.

6 pin. PGND

Power GND terminal of output terminal, N driver:

7 pin. CS

Inductor current detection resistor connecting terminal of DC/DC current mode: it transforms the current flowing through the inductor into voltage by sense resistor R_{CS} connected to CS terminal, and this voltage is compared with that set in the error amplifier by current detection comparator to control DC/DC output voltage. RCS also performs over current protection (OCP) and stops switching action when the voltage of CS terminal is 0.45 V (typ.) or higher (Pulse by Pulse).

8 pin. OVP

OVP terminal is the detection terminal of overvoltage protection (OVP) and short circuit protection (SCP) for DC/DC output voltage. Depending on the setting of the FAIL_MODE terminal, FAIL and CP terminal behave differently when an abnormality is detected. For details, see the table for each protection operation is described in ●3.2 and ●3.3.

During the soft start (SS), there is a function which returns the OVP voltage to error amplifier to boost DC/DC output voltage at all Low PWM (OVFPB function). After completion of SS, this function is disabled.

9 pin. M_DET

The Di OR output terminal of LED 1 to 6. The output is the voltage which is added a diode forward voltage(two diode stack) to the lowest voltage among 6 LED terminals.

10 pin. SUMPWM

This is a judging terminal if high signal is input to PWM terminal or not. Using in Master/slave mode, one SUMPWM terminal is connected to another. And if any PWM signal becomes high between master and slave, the SUMPWM terminal becomes high, too. For details, please refer to ●3.4 Connecting operation of Master/ slave.

11 to 16 pin. LED1 to LED6

LED constant current driver output terminal. Setting of LED current value is adjustable by setting the VREF voltage and connecting a resistor to S terminal. For details, see the explanation of <25 to 30pin. S1 to S6, 35pin. VREF >.

The PWM dimming frequency of LED current driver and upper/lower limit of the duty need to be set in a manner that necessary linearity of PWM dimming characteristics can be secured referring to the following figures:

Start/Stop time of constant current driver (PWM pulse response)

Start-up time depends on the VREF value; the response becomes quick, so that voltage is high.

In the way of reference, the current response upon application of current rise rate and pulse PWM1us (current pulse) to describe the dependence of VREF. It needs to be adequately verified with an actual device because the response rate may vary with application conditions.

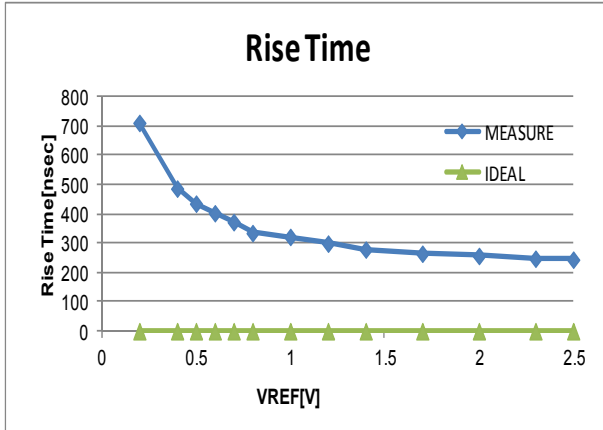

Figure 13.

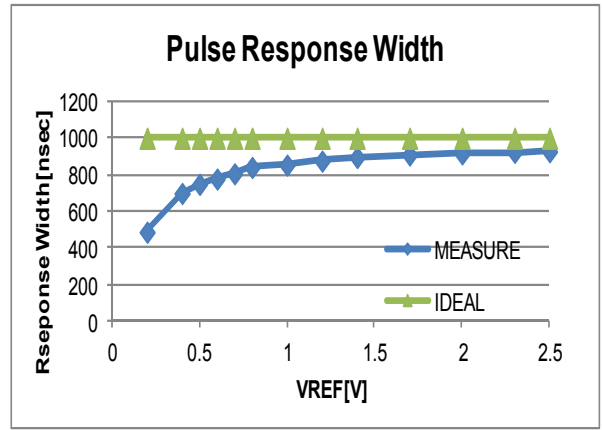

Figure 14.

17pin. STB

ON/OFF setting terminal for IC, which can be used perform a reset at shutdown.

* The voltage of STB input in the sequence of VCC → STB.

* Voltage input in STB terminal switches the state of IC (IC ON/OFF). Using the terminal between the 2 states (0.8 to 2.0 V) needs to be avoided.

18 to 23pin. PWM1 to PWM6

ON/OFF terminal of LED driver: it inputs PWM dimming signal directly to PWM terminal and change of DUTY enables dimming. High/Low level of PWM terminal is shown as follows:

State	PWM voltage
LED ON	PWM= 2.0 to 20V
LED OFF	PWM= -0.3 to 0.8V

24pin.FAIL_RST

Reset terminal of the protection circuit and FAIL terminal:

Return the latch stopped protection block by setting the FAIL_RST to High. During High state, operation is masked by the latch system protection.

25 to 30pin. S1 to S6, 35pin. VREF

S terminal is a connecting terminal for LED constant current setting resistor, output current ILED is in an inverse relationship to the resistance value.

VREF terminal is a terminal for analog dimming; output current ILED is in a proportional relationship to the voltage value to be input.

VREF terminal is assumed that it is set by dividing the resistance with a high degree of accuracy, VREF terminal inside the IC is in open state (High Impedance). It is necessary to input voltage to divide the resistance from the output of REG9V or use external power source. Using the terminal in open state needs to be avoided.

The relationship among output current ILED, VREF input voltage, and RS resistance has the following equation:

$$I_{LED} = \frac{VREF[V]}{RS[\Omega]} \times 0.2[A]$$

The voltage of S terminal is following equation:

$$VS = 0.2 \times VREF[V]$$

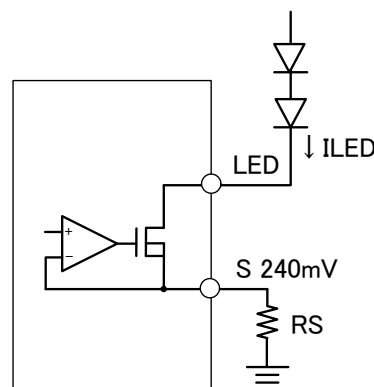

VREF=1.2V, RS=2 [Ω]
ILED=120[mA]

Figure 15.

*Attention: Rises LED current accelerate heat generation of IC. Adequate consideration needs to be taken to thermal design in use.

* For the adjustment of LED current with analog dimming by VREF, note that the output voltage of the DC/DC converter largely changes accompanied by LED VF changes if the VREF voltage is changed rapidly. In particular, when the VREF voltages become high to low, it makes the LED terminal voltage seem higher transiently, which may influence application such as activation of the LED short circuit protection. It needs to be adequately verified with an actual device when analog dimming is used.

31pin. CP

Terminal which sets the time from detection of abnormality until shutdown (Timer latch). When the LED short protection, LED open protection or SCP is detected, it performs a constant current charge of 1.0uA (typ.) to external capacitor. When the CP terminal voltage reaches 2.0V (typ.), the IC is latched and FAIL terminal operates (at FAIL_MODE = L).

32pin. SS

Terminal which sets soft-start time of DC/DC converter: it performs constant current charge of 1.0uA to the external capacitor connected with SS terminal, which enables soft-start of DC/DC converter.

Since the LED protection function (OPEN/SHORT detection) works when the SS terminal voltage reaches 3.0 V (typ.) or higher, it must be set to bring stability to conditions such as DC/DC output voltage and LED constant current drive operation, etc. before the voltage of 3.0 V is detected.

33pin. FB

Output terminal of the error amplifier of DC/DC converter which controls current mode:

The voltage of LED terminal which is the highest VF voltage among 6 LED strings and the voltage of LED_LV terminal become input of the error amplifier. The DC/DC output voltage is kept constant to control the duty of the output N terminal by adjusting the FB voltage.

The voltage of other LED terminals is, as a result, higher by the variation of Vf. Phase compensation setting is separately described in ●3.7 How to set phase compensation.

A resistor and a capacitor need to be connected in series nearest to the terminal between FB and AGND.

The state in which all PWM signals are in LOW state brings high Impedance, keeping FB voltage. This action removes the time of charge to the specified voltage, which results in speed-up in DC/DC conversion.

34pin. RT

RT sets charge/discharge current determining frequency inside IC.

Only a resistor connected to RT determines the drive frequency inside IC, the relationship has the following equation: FCT is 500 kHz at RT= 30 kohm.

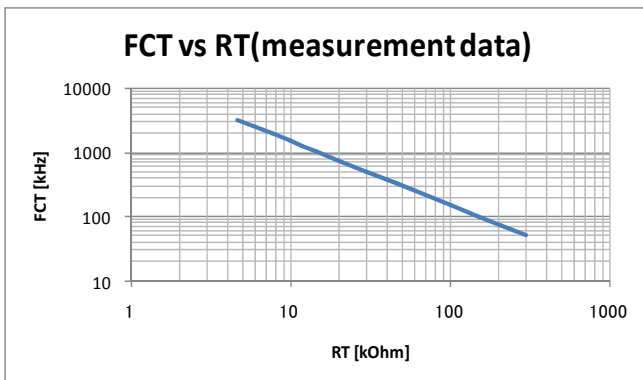

Figure 16.

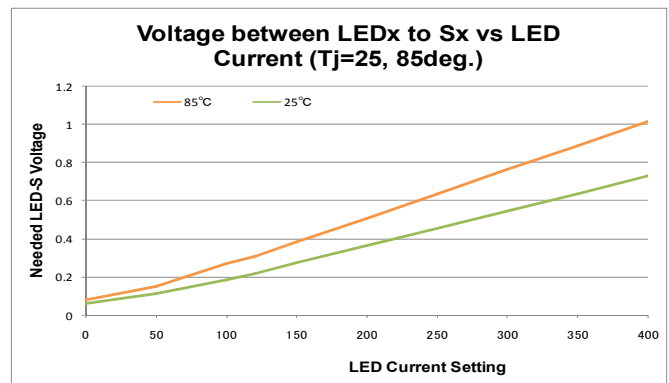

Figure 17.

36pin. LED_LV

LED_LV terminal sets the reference voltage error amplifier. LED_LV terminal is assumed that it is set by dividing the resistance with a high degree of accuracy, LED_LV terminal inside the IC is in open state (High Impedance). It is necessary to input voltage to divide the resistance from the output of REG9V or use external power source. Using the terminal in open state needs to be avoided.

According to output current, lowering LED_LV voltage can reduce the loss and heat generation inside IC. However, it is necessary to ensure the voltage between drain and source of FET inside IC, so LED_LV voltage has restriction on the following equation.

$$V_{LED_LV} \geq (\text{LED-S terminal voltage}) + 0.2 \times V_{REF} [V]$$

For example, at ILED = 100mA setting by VREF = 1V, from figure the voltage between LED and S terminal is required 0.27 V at Tj = 85°C, so LED_LV voltage must be at least a minimum 0.47V.

Note: Rises in VLED_LV voltage and LED current accelerate heat generation of IC. Adequate consideration needs to be taken to thermal design in use.

Note: LED_LV voltage is not allowed setting below 0.3V.

Note: LED current by raising LED_LV voltage can flow to MAX 400mA, use with care in the dissipation of the package.

37pin. LSP

Terminal which sets LED SHORT detection voltage: The input impedance of LSP pin is High Impedance, because it is assumed that the input of LSP terminal is set by dividing the resistance with a high degree of accuracy.

The LSP terminal is assumed that it is set by dividing the resistance with a high degree of accuracy, LSP terminal inside the IC is in open state (High Impedance). It is necessary to input voltage to divide the resistance from the output of REG9V or use external power source. Using the terminal in open state needs to be avoided. Set LSP voltage in the range of 0.8V to 3.0V.

$$LED_{SHORT} = 5 \times VLSP \text{ [V]}$$

LED_{SHORT}: LSP detection Voltage, VLSP: LSP terminal voltage

The conditions there are restrictions on short LED detection. For details, see the explanation of section ●3.5.2 Setting the LED short detect voltage (LSP pin).

38pin. FAIL_MODE

Output mode of FAIL can be change by FAIL_MODE terminal. When FAIL_MODE is in Low state, the output of FAIL terminal is the latch mode. FAIL terminal is latched after the CP charge time from detection of abnormal state. When FAIL_MODE is in High state, the output of FAIL terminal is one-shot-pulse mode. At detected abnormality, firstly FAIL is in Low state (Drain state). FAIL returns to High state (Open state) if abnormality is cleared after CP charge time, In this mode, there is no latch stop for protection operation in IC. Monitoring the FAIL with the Microcomputer, decide to stop working IC.

For FAIL_MODE = H when the detection sequence, see the explanation of section ●3.8.3 Protective operation sequence at FAIL_MODE=H. On application to change modes is prohibited.

39pin. UVLO

UVLO terminal of the power of step-up DC/DC converter: at 2.5 V (typ.) or higher, IC starts step-up operation and stops at 2.3V or lower (typ.). (It is not shutdown of IC.) UVLO can be used to perform a reset after latch stop of the protections.

The power of step-up DC/DC converter needs to be set detection level by dividing the resistance. If any problem on the application causes noise on UVLO terminal which results in unstable operation of DC/DC converter, a capacitance of approximately 1000 pF needs to be connected between UVLO and AGND terminals.

40pin. AGND

Analog GND for IC

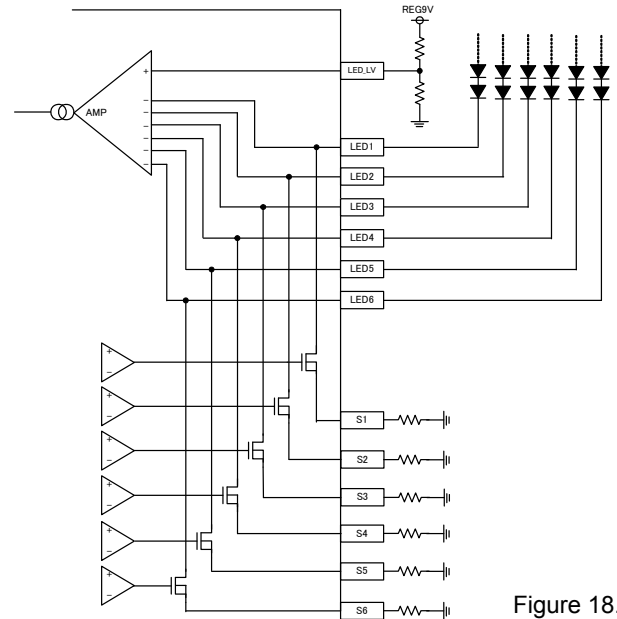

Figure 18.

●3.2 Protection Operation at FAIL Latch output (FAILMODE=L)

●3.2.1 List of the Threshold Function terminal (typ. condition)

Please decide the resistance divider of the various protection detection using the following table.

Protection name	Detection Pin name	Detection condition	PWM	Release condition	Protection type
LED Open	LEDx	LEDx < 0.2V(4clk) SS>3V	High	LEDx > 0.2V(*1)	Stop the CH latch after the CP charge is completed.
LED short	LEDx	LEDx > 5×VLSP(4clk) SS>3V	High	LEDx < 5×VLSP(3clk)	Stop the CH latch after the CP charge is completed.
UVLO	UVLO	UVLO < 2.3V	—	UVLO > 2.5V	Stop the system
OVP	OVP	OVP > 2.43V	—	OVP < 2.4V	Stop the N output
SCP	OVP	OVP < 0.2V	—	OVP > 0.2V	Stop the N output. Stop the system after the CP charge is completed.
OCP	CS	CS > 0.45V	—	CS < 0.45V	Stop the N output under the detection. (Pulse by Pulse)

It is possible to reset with the FAIL_RST terminal to release the latch stop.

(*1) The release condition of OPEN protection is depend on its release timing.

No.	The timing of release of LEDx voltage (LEDx 0.2V)	The release condition
1	LED pin voltage is released during PWM=H.	LED pin voltage is normal range during 3clk(3 positive edge)
2	LED pin voltage is released during PWM=L.	As PWM=L, LED pin voltage do not exceed Short protection voltage (VLSP) during more than 3clk. or PWM positive edge is input when LED pin voltage do not exceed VLSP for more than 3clk.

●3.2.2 List of Protection function

Protection function	Action when protection function is detected			
	DC/DC converter	LED driver	Soft-start	FAIL terminal
STB	Stop	Stop	Discharge	OPEN
LED Open	Normal operation (Stop when all LED CH stop)	Stop after CP charge (Latch operation)	Normal operation	DRAIN after the CP charge is completed. (Latch operation)
LED short	Normal operation *1	Stop after CP charge (Latch operation)	Normal operation	DRAIN after the CP charge is completed. (Latch operation)
UVLO	Stop	Stop	Discharge	GND
OVP	Stop N output	Normal operation	Normal operation	OPEN
SCP	Stop N output	Stop after CP charge (Latch operation)	Discharge after latch	DRAIN after the CP charge is completed. (Latch operation)
OCP	Stop the N output (Pulse by Pulse)	Normal operation	Normal operation	OPEN

(*1) Short protection doesn't hang when becoming remainder 1ch. DCDC output falls as LED short.

●3.3 Protection operation when the FAIL one shot outputs(FAILMODE=H)

●3.3.1 List of the threshold function terminal (typ. condition)

Please decide the resistance divider of the various protection detection using the following table.

Protection name	Detection Pin name	Detection condition	PWM	Release condition	Protection type
LED Open	LEDx	LEDx < 0.2V(4clk) SS>3V	High	LEDx > 0.2V(3clk)	FAIL drain state under the detection.
LED short	LEDx	LEDx > 5×VLSP(4clk) SS>3V	High	LEDx < 5×VLSP(3clk)	FAIL drain state under the detection.
UVLO	UVLO	UVLO < 2.3V	—	UVLO > 2.5V	Stop the system.
OVP	OVP	OVP > 2.43V	—	OVP < 2.4V	Stop the system FAIL drain state under the detection..
SCP	OVP	OVP < 0.2V	—	OVP > 0.2V	Stop the system. FAIL drain state under the detection..
OCP	CS	CS > 0.45V	—	CS < 0.45V	Stop the N output under the detection. (Pulse by Pulse)

●3.3.2 List of the protection function

Protection function	Action when protection function is detected			
	DC/DC converter	LED driver	Soft-start	FAIL terminal
STB	Stop	Stop	Discharge	OPEN
LED Open	Normal operation (Stop when the all CH stop)	Normal operation	Normal operation	DRAIN under the detection
LED short	Normal operation	Normal operation	Normal operation	DRAIN under the detection
UVLO	Stop	Stop	Discharge	DRAIN
OVP	Stop the N output	Normal operation	Normal operation	DRAIN
SCP	Stop the N output	Normal operation	Normal operation	DRAIN
OCP	Stop the N output (Pulse by Pulse)	Normal operation	Normal operation	OPEN

●3.4 Connecting operation of Master/ slave

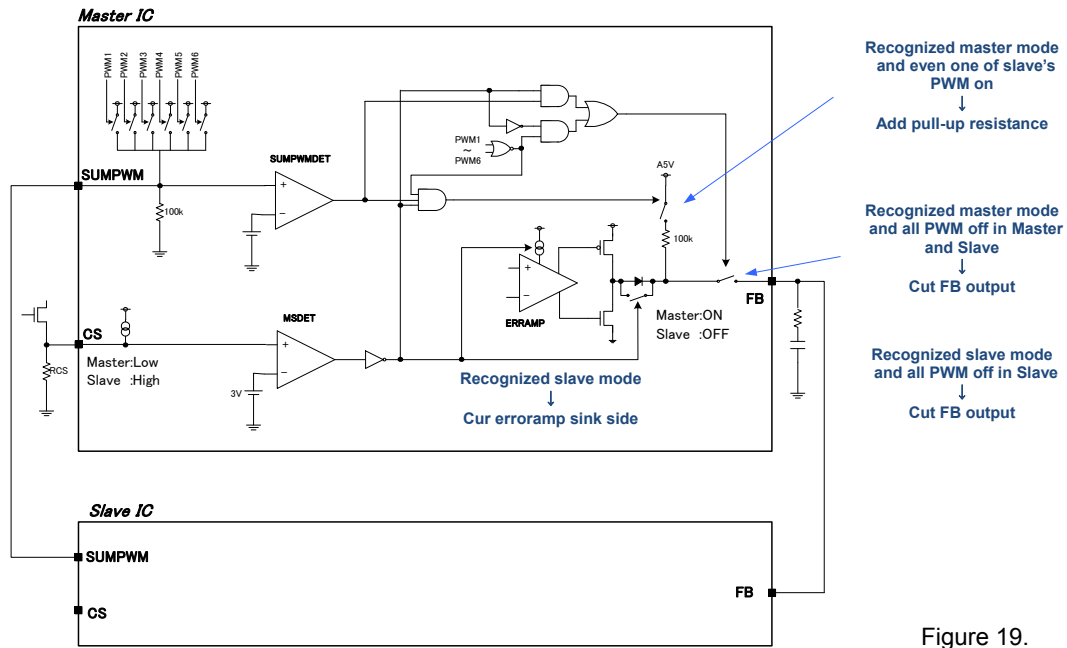

Figure 19.

Connecting plural BD9422EFVs makes it a Master/slave, a DCDC in Master construct a system to drive LED driver. Here, explanation of Master/slave operation in connecting 2 ICs.

[MSDET] Converter for recognizing Master/slave

Detect the voltage of CS terminal to judge master or slave of itself. The CS terminal of slave is OPEN when the Master/slave mode is used. The CS terminal is high due to being supplied constant current from IC inside. The CS terminal of Master is connected a resistance for DCDC switching current detection and swing 0V to 0.45V on operating. Converter can detect the differences of the voltage, which is a Master/slave recognizing signal.

[SUMPWMDDET] Converter for all PWM signal detection

SUMPWM terminal is connected a switch that is ON when the PWM signal is high and a pull down resistance 100kΩ. SUMPWM terminal becomes high more than one PWM signals are high. When the SUMPWM terminal is connected between master and slave, it can judge if more than one signals of the entire PWM signal in master/slave becomes high.

The operation of error amplifier part is decided by the signal of MSDET and SUMPWM

1. Error amplifier output part Diode/non diode

If the IC recognizes slave mode, the diode is connected to error amplifier output and cut the supply of sink side of error amplifier.

2. Error amplifier output part Pull up resistance/ non pull up resistance

If the IC recognizes master mode and the PWM of slave become ON more than one, the pull up resistance is connected.

3. Error amplifier output FB output cut

In master recognizing, if all the PWM signals are OFF error amplifier output is cut.

In slave recognizing, if all the PWM signals of slave side are OFF error amplifier output is cut.

These are collected, the table below.

		Use for Master/Slave mode					
Master	Slave	Master			Slave		
		Error Amplifier output			Error Amplifier output		
		source	sink	pull up	source	sink	pull up
PWM ON	PWM ON	○	○	—	○	—	—
PWM ON	PWM OFF	○	○	—	—	—	—
PWM OFF	PWM ON	○	○	○	○	—	—
PWM OFF	PWM OFF	—	—	—	—	—	—
		Use for Master only					
Master		Master					
		Error Amplifier output					
		source	sink	pull up			
PWM ON	○	○	—				
PWM OFF	—	—	—				

●3.5 Setting of the external components.(typ. condition)

●3.5.1 Setting the LED current (VREF and Sx pin)

First, VREF pin voltage is determined. When performing Analog dimming, be careful of VREF pin input range (0.2 to 2.5V) and decide typical voltage.

In BD9422EFV, LED constant current is controlled by Sx terminal voltage as a reference point. Sx terminal is controlled to become one fifth of the voltage of VREF terminal voltage. In the case of VREF=1V, it is set to Sx=0.2V.

Therefore, when the resistance to Sx terminal versus GND is set to "RS", the relationship between RS, VREF and ILED is as follows

$$R_S [\text{ohm}] = \frac{V_{VREF} [\text{V}]}{I_{LED} [\text{A}] \times 5}$$

●3.5.2 Setting the LED short detect voltage (LSP pin)

The voltage of LED short detection can be arbitrarily set up with LSP pin voltage.

LSP pin cannot be used by OPEN because of High Impedance. Please be sure to applied voltage from the exterior. About LED short detection voltage, if "VLEDshort" and LSP pin voltage are set to "VLSP", it is as follows.

$$V_{LSP} [\text{V}] = \frac{V_{LED_{short}} [\text{V}]}{5}$$

Since the setting range of a LSP pin is set to 0.8V to 3.0V, VLEDshort can be set up in 4Vto15V.

○Equation of setting LSP detect Voltage

When the detection voltage VLSP of LSP is set up by resistance division of R1 and R2 using REG9V, it becomes like the following formula.

$$V_{LED_{short}} = \left(REG9V \times \frac{R2}{R1 + R2} \right) \times 5 \quad [\text{V}]$$

*Also including the variation in IC, please also take the part variation in a set into consideration for an actual constant setup, and inquire enough to it.

●3.5.3 Timer latch time(CP pin)

When various abnormalities are detected, the source current of 1.0uA is first flowed from CP pin.

BD9422EFV don't stop by latch, unless abnormal state is continues and CP pin voltage reaches continues 2V.

With the capacity linked to CP pin, the unresponded time from detection to a latch stop. The relationship between the unresponded time "T_{cp}" and CP pin connection capacitor "C_{cp}" is as follows.

$$C_{CP} [\text{F}] = \frac{T_{CP} [\text{S}] \times 1.0 \times 10^{-6} [\text{A}]}{2.0 [\text{V}]}$$

●3.5.4 Setting the soft-start time (SS pin)

The starting time of a DCDC output is dependent on SS pin connection capacity.

Moreover, although SS pin is charged by source current of 1uA, IC does not perform LED protection as under DCDC starting state until SS pin voltage arrive to 3.0V.

(The soft starting time set up here should be the mask time of a under [starting], and please keep in mind that it differs from time until a DCDC output is stabilized.)

Time until a DCDC output is stabilized is greatly dependent on a ratio of step-up or load.

The relationship between soft starting time "T_{SS}" and SS pin connection capacity "C_{SS}" is as follows.

$$C_{SS} [\text{F}] = \frac{T_{SS} [\text{S}] \times 1.0 \times 10^{-6} [\text{A}]}{3.0 [\text{V}]}$$

●3.5.5 DCDC operation frequency (RT pin)

The oscillation frequency of the DCDC output is decided by RT resistance.

BD9422EFV is designed to become a 500-kHz setup at the time of 30kohm.

RT resistance and frequency have a relation of an inverse proportion, and become settled as the following formula.

$$R_{RT} = \frac{1.5 \times 10^{10}}{f_{sw}} [\Omega] \quad f_{sw} = \text{DCDC convertor oscillation frequency [Hz]}$$

Please connect RT resistance close as much as possible from RT pin and an AGND pin.

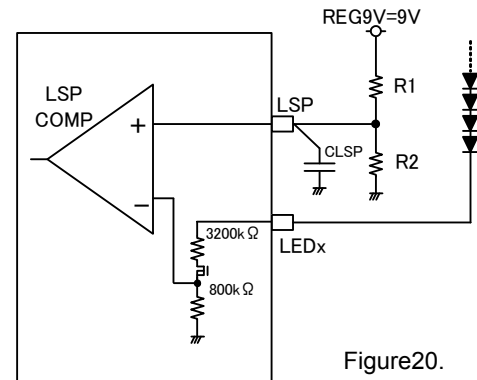

Figure20.

●3.5.6 Maximum DCDC output voltage(Vout ,Max)

The DCDC output maximum voltage is restricted by Max Duty of N output. Moreover, the voltage needed in order that Vf may modulate by LED current also with the same number of LEDs. Vf becomes high, so that there is generally much current. When you have grasped the variation factor of everythings, such as variation in a DCDC input voltage range, the variation and temperature characteristics of LED load, and external parts, please carry out a margin setup.

●3.5.7 Setting the OVP

In BD9422EFV, when over voltage in VOUT line is detected, the instant stop of the N pin output is carried out, and voltage rise operation is stopped. But the latch stop by CP charge is not performed. If VOUT drops by naturally discharge, it is less than the hysteresis voltage of OVP detection and the oscillation condition is fulfilled, N output will be resumed again.

○Equation of setting OVP detect

$$VOVP = 2.43 \times \frac{R1 + R2}{R2} \quad [V]$$

N pin output is suspended at the time of SCP detection, it stops step-up operation, and the latch protection by CP timer.

○Equation of setting SCP detect

$$VSCP = 0.2 \times \frac{R1 + R2}{R2} \quad [V]$$

Moreover, there is an OVFPB function which returns OVP voltage and controls error amplifier so that output voltage may be raised, even when there is no PWM signal during a soft start.

○The VOUT setting formula by OVFPB in Soft Start

$$VOUT = \left(\frac{3}{2} \frac{R1 + R2}{R2} + \frac{R1}{400} \right) \times V_{LED_LV} \quad [V]$$

●3.5.8 FAIL Logic

FAIL signal output pin (OPEN DRAIN); when an abnormality is detected, NMOS is brought into GND Level. The rating of this pin is 36V.

State	FAIL output
In normal state, In STB	OPEN
In completion of an abnormality, when the UVLO is detected(after CP latch)	GND Level (500ohm typ.)

●3.5.9 How to set the UVLO

UVLO pin detect the power supply voltage: Vin for step-up DC/DC converters. Operation starts operation on more than 2.5V (typ.) and Operation stops on less than 2.3V (typ.) .

Since internal impedance exists in UVLO pin, cautions are needed for selection of resistance for resistance division.

A Vin voltage level to make it detecting becomes settled like the following formula by resistance division of R1 and R2 (unit: kΩ).

○Equation of setting UVLO release

$$Vin_{DET} = 2.5 \times \left\{ \frac{R1 + R2}{R2} + \left(\frac{1}{1400k + 125k} + \frac{1}{530k + 480k} \right) \times R1 \right\} \quad [V]$$

○Equation of setting UVLO lock

$$Vin_{lock} = 2.3 \times \left\{ \frac{R1 + R2}{R2} + \left(\frac{1}{1400k + 125k} + \frac{1}{530k + 480k + 87k} \right) \times R1 \right\} \quad [V]$$

*Also including the variation in IC, please also take the part variation in a set into consideration for an actual constant setup, and inquire enough to it.

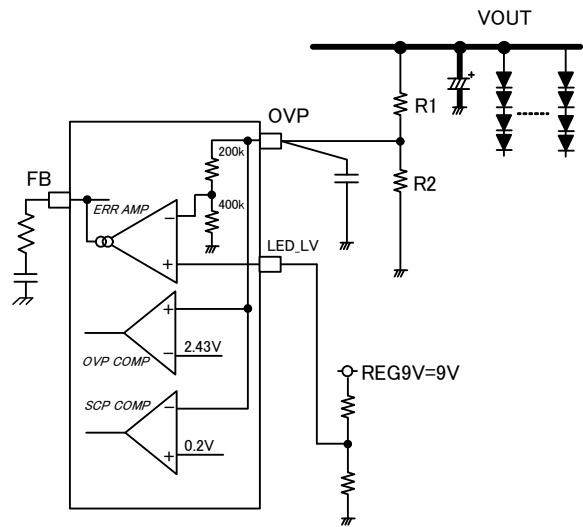

Figure21.

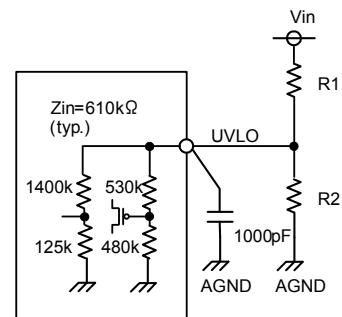

Figure 22.

●3.5.10 Setting of the LED_LV voltage (LED_LV pin)

LED_LV pin is in the OPEN (High Impedance) state.

Please be sure to use an external seal of approval, carrying out by inputting REG9V output by resistance division. It cannot use in the state of OPEN.

○Equation of Setting LED_LV voltage

When LED_LV voltage is set up by resistance division of R1 and R2 using REG9V, it becomes like the following formula.

$$V_{LED_LV} = REG9V \times \frac{R2}{R1 + R2} [V]$$

*Also including the variation in IC, please also take the part variation in a set into consideration for an actual constant setup, and inquire enough to it.

●3.6 Selecting of DCDC part

Selecting inductor L

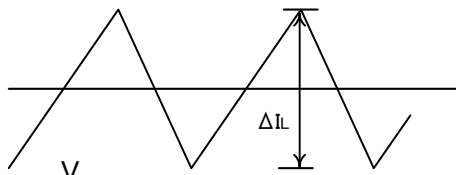

Figure 23.

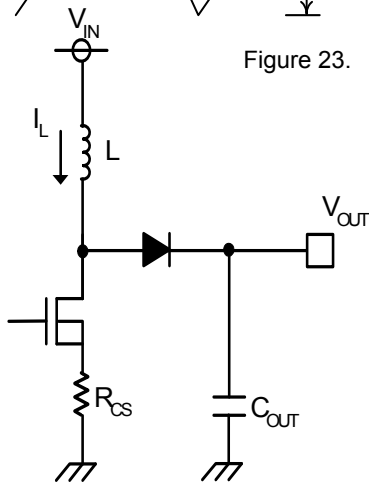

Figure 24.

The value of inductor has a great influence on input ripple current. As shown in Equation (1), as the inductor becomes large and switching frequency becomes high, the ripple current of an inductor ΔIL becomes low.

$$\Delta IL = \frac{(V_{OUT} - V_{IN}) \times V_{IN}}{L \times V_{OUT} \times f_{SW}} [A] \quad \dots \dots \dots (1)$$

When the efficiency is expressed by Equation (2), input peak current will be given by Equation (3).

$$\eta = \frac{V_{OUT} \times I_{OUT}}{V_{IN} \times I_{IN}} \quad \dots \dots \dots (2)$$

$$I_{LMAX} = I_{IN} + \frac{\Delta IL}{2} = \frac{V_{OUT} \times I_{OUT}}{V_{IN} \times \eta} + \frac{\Delta IL}{2} \quad \dots \dots \dots (3)$$

Here,

L: reactance value [H] V_{OUT}: DC/DC output voltage [V]

V_{IN}: input voltage [V]

I_{OUT}: output load current (total of LED current) [A]

I_{IN}: input current [A] F_{SW}: oscillation frequency [Hz]

Generally, ΔIL is set at around 30 to 50 % of output load current.

* Current exceeding the rated current value of inductor flown through the coil causes magnetic saturation, resulting in decrease in efficiency. Inductor needs to be selected to have such adequate margin that peak current does not exceed the rated current value of the inductor.

* To reduce inductor loss and improve efficiency, inductor with low resistance components (DCR, ACR) needs to be selected.

Selecting output capacitor C_{OUT}

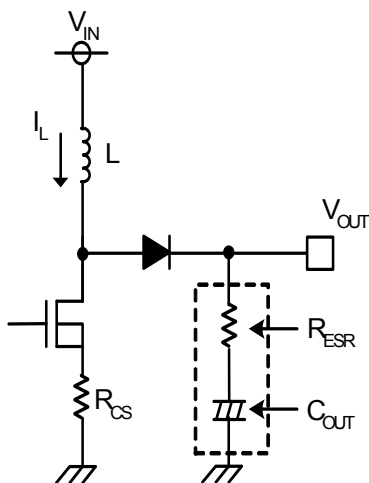

Figure 25.

Output capacitor needs to be selected in consideration of equivalent series resistance required to even the stable area of output voltage or ripple voltage. Be aware that set LED current may not be flown due to decrease in LED terminal voltage if output ripple voltage is high.

Output ripple voltage ΔV_{OUT} is determined by Equation (4):

$$\Delta V_{OUT} = I_{LMAX} \times R_{ESR} + \frac{1}{C_{OUT}} \times \frac{I_{OUT}}{\eta} \times \frac{1}{f_{SW}} [V] \quad \dots \dots \dots (4)$$

R_{ESR}: equivalent series resistance of C_{OUT}

* Rating of capacitor needs to be selected to have adequate margin against output voltage.

* To use an electrolytic capacitor, adequate margin against allowable current is also necessary. Be aware that current larger than set value flows transitionally in case that LED is provided with PWM dimming especially.

Selecting switching MOSFET

Though there is no problem if the absolute maximum rating is the rated current of L or (withstand voltage of C_{OUT} + rectifying diode) VF or higher, one with small gate capacitance (injected charge) needs to be selected to achieve high-speed switching.

- * One with over current protection setting or higher is recommended.
- * Selection of one with small ON resistance results in high efficiency.

Selecting rectifying diode

A schottky barrier diode which has current ability higher than the rated current of L, reverse voltage larger than withstand voltage of C_{OUT}, and low forward voltage VF especially needs to be selected.

Selecting MOSFET for load switch and its soft-start

As a normal step-up DC/DC converter does not have a switch on the path from V_{IN} to V_{OUT}, output voltage is generated even though IC is OFF. To keep output voltage at 0 V until IC works, PMOSFET for load switch needs to be inserted between V_{IN} and the inductor. FAIL terminal needs to be used to drive the load switch. PMOSFET for the load switch of which gate-source withstand voltage and drain-source withstand voltage are both higher than V_{IN} needs to be selected. To provide soft-start for the load switch, a capacitor must be inserted among gates and sources.

●3.7 How to set phase compensation

DC/DC converter application controlling current mode has each one pole (phase lag) f_p due to CR filter composed of output capacitor and output resistance (= LED current) and ZERO (phase lead) f_z by output capacitor and ESR of the capacitor. Moreover, step-up DC/DC converter has RHP ZERO f_{ZRHP} as another ZERO. Since RHP ZERO has a characteristic of phase lag (-90°) as pole does, cross-over frequency f_c needs to be set at RHP ZERO or lower.

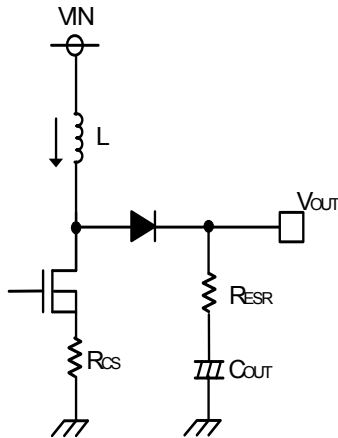

Figure 26. Output part

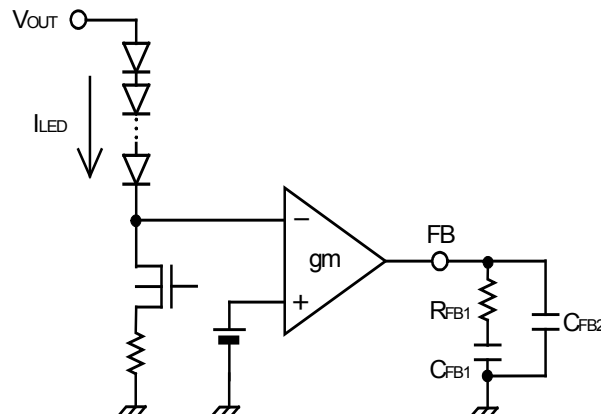

Figure 27. Error Amplifier

- i. Determine Pole f_p and RHPZERO f_{ZRHP} of DC/DC converter:

$$f_p = \frac{I_{LED}}{2\pi \times V_{OUT} \times C_{OUT}} [Hz] \quad f_{ZRHP} = \frac{V_{OUT} \times (1-D)^2}{2\pi \times L \times I_{LED}} [Hz]$$

$$\text{Here, } I_{LED} = \text{sum of LED current, } D = \frac{V_{OUT} - V_{IN}}{V_{OUT}}$$

- ii. Determine Phase compensation to be inserted into error amplifier (with f_c set at 1/5 of f_{ZRHP})

$$R_{FB1} = \frac{f_{RHZP} \times R_{CS} \times I_{LED}}{5 \times f_p \times gm \times V_{OUT} \times (1-D)} [\Omega] \quad C_{FB1} = \frac{1}{2\pi \times R_{FB1} \times f_p} [F]$$

Here,

$$gm = 1.036 \times 10^{-3} [S]$$

- iii. Determine ZERO to compensate ESR (R_{ESR}) of C_{OUT} (electrolytic capacitor)

$$C_{FB2} = \frac{R_{ESR} \times C_{OUT}}{R_{FB1}} [F]$$

* When a ceramic capacitor (with R_{ESR} of the order of millimeters) is used to C_{OUT}, too, operation is stabilized by insertion of R_{ESR} and C_{FB2}.

Though increase in R_{FB1} and decrease in C_{FB1} are necessary to improve transient response, it needs to be adequately verified with an actual device in consideration of variation between external parts since phase margin is decreased.

•3.8 Timing chart
 •3.8.1 Normal operation sequence

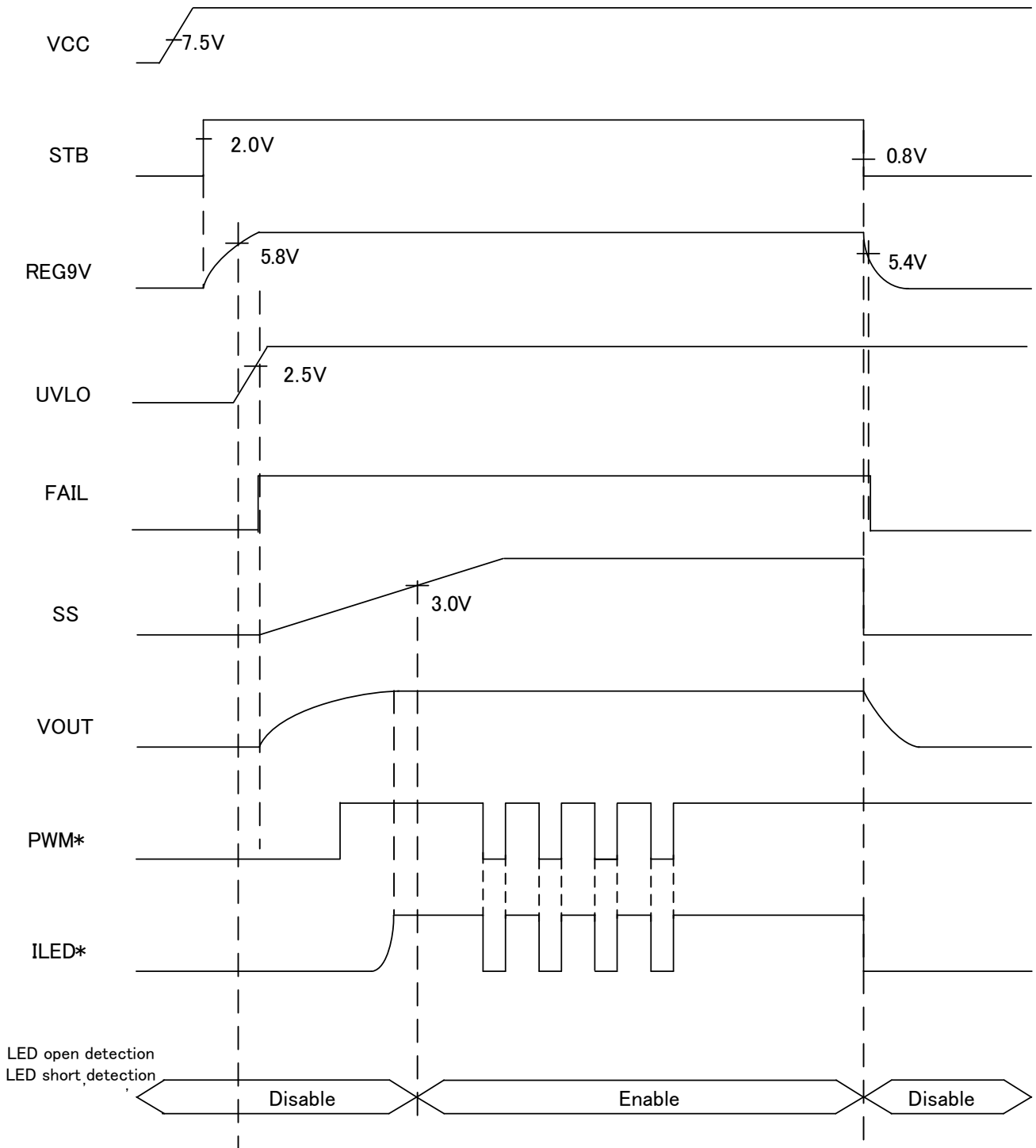

- ILED* current is independent controlled by each PWM* pin.
- FAIL pin is pulled up.

Figure 28.

●3.8.2 Protective operation state transition table at FAIL_MODE=L

(Open detection)

before CP charge		→	CP charge		→	CP=2V arrival		end of state
PWM	Error state		PWM	Error state		PWM	Error state	
L(no pulse) or pulse less than 4cnt	don't care	discharge	-	-		-	-	normal state
pulse over 4cnt.	Not detect	discharge	-	-		-	-	normal state
	detect	start charge	L(no pulse)	Not detect	discharge	-	-	normal state
				detect	charge	L(no pulse)	Not detect	normal state
				detect	charge	L(no pulse)	detect	CH latch FAIL latch
				detect	charge	H(input pulse)	Not detect	normal state
			detect	charge	H(input pulse)	detect	CH latch FAIL latch	
			H(input pulse)	Not detect	discharge	-	-	normal state
				detect	charge	L(no pulse)	Not detect	normal state
				detect	charge	L(no pulse)	detect	CH latch FAIL latch
	detect	charge		H(input pulse)	Not detect	normal state		
detect	charge	H(input pulse)	detect	CH latch FAIL latch				

(Short detection)

before CP charge		→	CP charge		→	CP=2V arrival		end of state
PWM	Error state		PWM	Error state		PWM	Error state	
L(no pulse) or pulse less than 4cnt	don't care	discharge	-	-		-	-	normal state
pulse over 4cnt.	Not detect	discharge	-	-		-	-	normal state
	detect	start charge	L(no pulse)	don't care	charge	L(no pulse)	don't care	CH latch FAIL latch
				don't care	charge	H(input pulse)	Not deetect	normal state
				detect	charge	H(input pulse)	detect	CH latch FAIL latch
				detect	charge	H(input pulse)	detect	CH latch FAIL latch
			H(input pulse)	Not detect	discharge	-	-	normal state
				detect	charge	L(no pulse)	don't care	CH latch FAIL latch
				detect	charge	L(no pulse)	Not deetect	normal state
				detect	charge	H(input pulse)	detect	CH latch FAIL latch

With "the pulse of less than 4 cnt", it is defined as the pulse width from (100n)sec to (Hi time of less than 4 cnt of DCDC frequency). In the pulse below (100n)sec, since delay from a PWM pin input to internal logic exists, it becomes unfixed.

•3.8.3 Protective operation sequence at FAIL_MODE=H

• Basic sequence

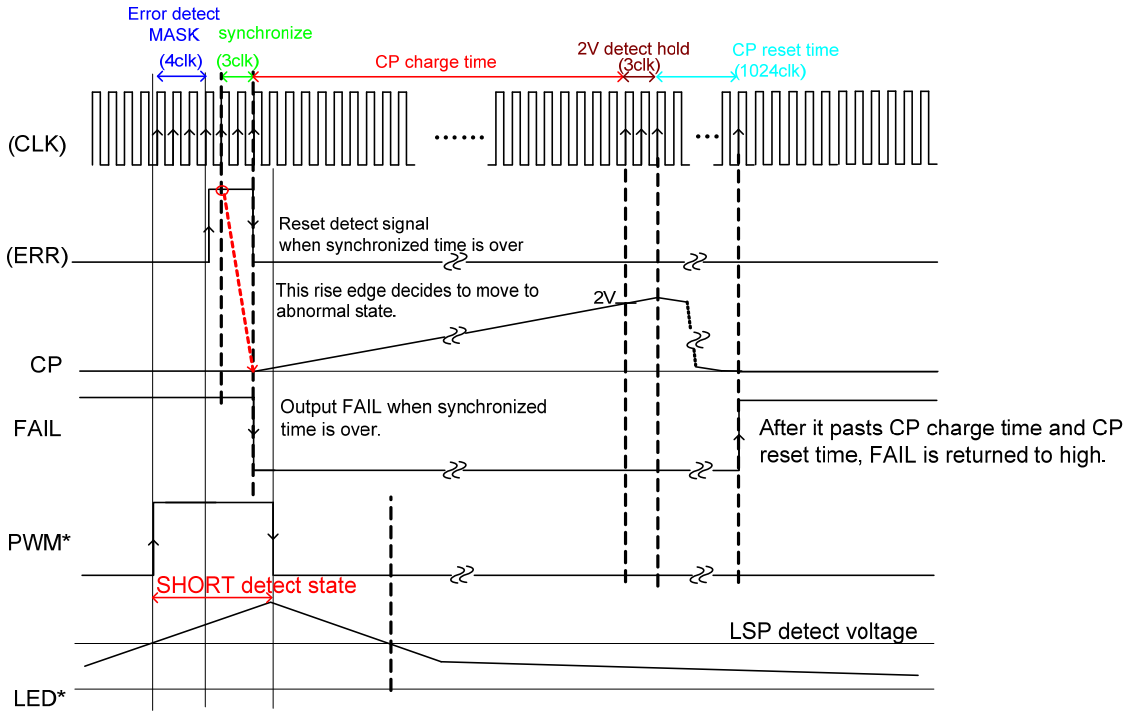
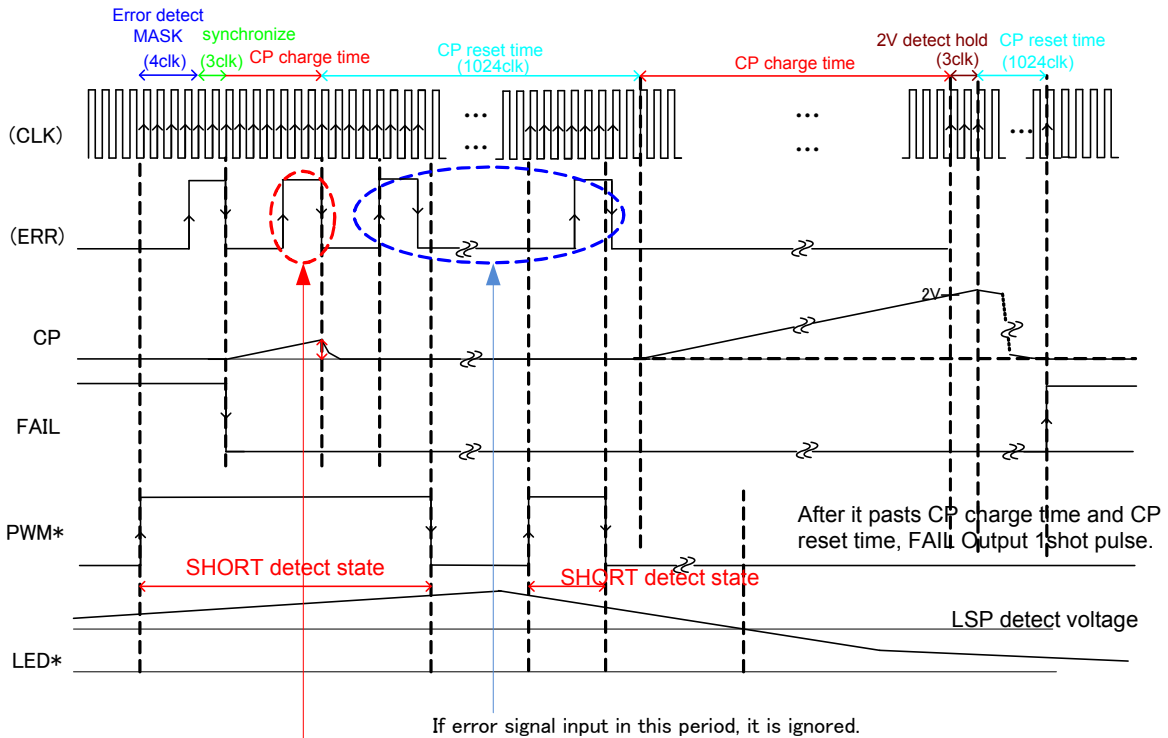

Figure 29.

• Actual sequence



Discharge CP by 2 times error signal
 Charge is started at 1 times error detect, but it moved to reset period at 2 times error detect immediately, therefore error signal can't be detected.

Figure 30.

The above chart is sample of SHORT detection, but the chart of OPEN detection is also same structure.

●3.8.4 About LED SHORT detection

LED SHORT detection don't work by individual ch. The followings are needed for detection.

- Detection channel is PWM=H and LED terminal voltage is over LED SHORT detection threshold voltage.
- Except for detection ch, any 1ch is PWM=H and LED terminal voltage is under 3V.
- The above-mentioned 2 states continue over 4clk of DCDC oscillation frequency.

Detection sequence is the followings.(omit 4clk mask)

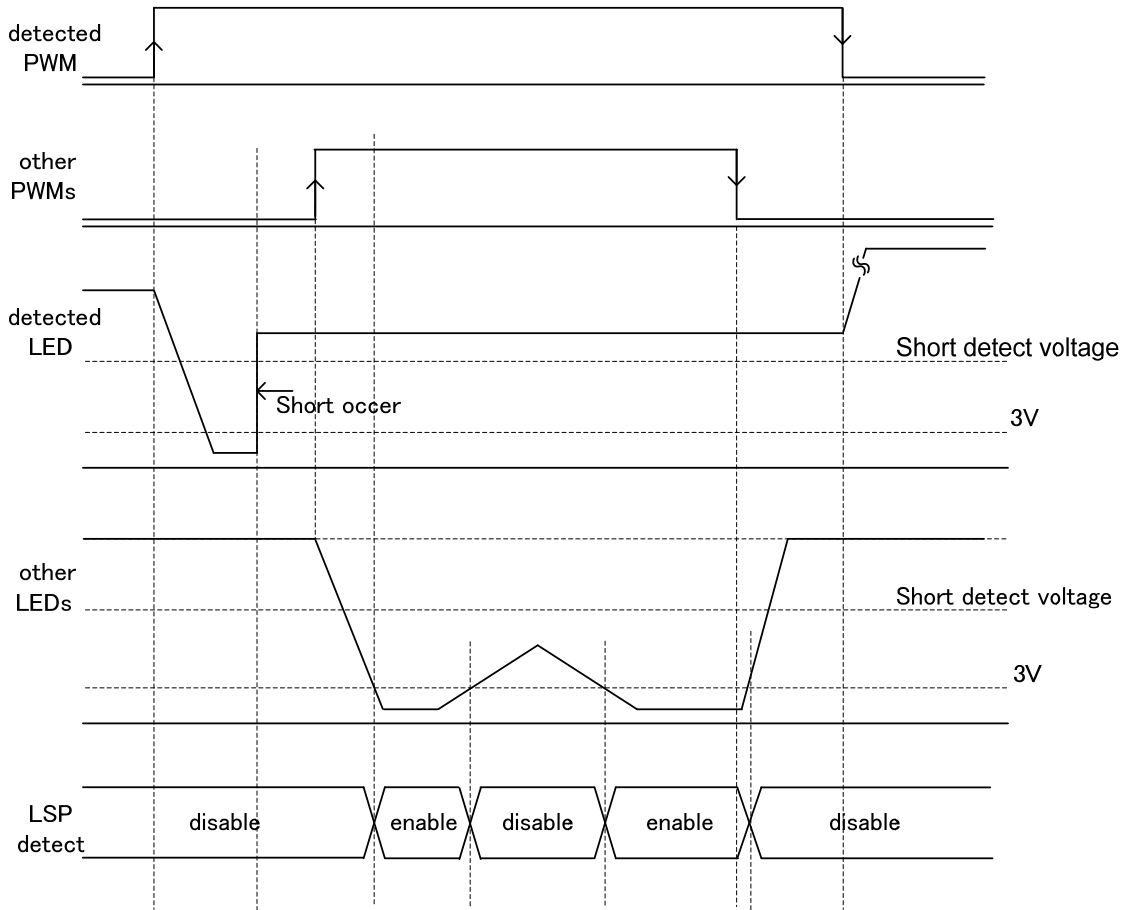

Figure 31.

●Operational Notes

- 1.) This product is produced with strict quality control, but might be destroyed if used beyond its absolute maximum ratings including the range of applied voltage or operation temperature. Failure status such as short-circuit mode or open mode can not be estimated. If a special mode beyond the absolute maximum ratings is estimated, physical safety countermeasures like fuse needs to be provided.
- 2.) Connecting the power line to IC in reverse polarity (from that recommended) may cause damage to IC. For protection against damage caused by connection in reverse polarity, countermeasures, installation of a diode between external power source and IC power terminal, for example, needs to be taken.
- 3.) When this product is installed on a printed circuit board, attention needs to be paid to the orientation and position of IC. Wrong installation may cause damage to IC. Short circuit caused by problems like foreign particles entering between outputs or between an output and power GND also may cause damage.
- 4.) Since the back electromotive force of external coil causes regenerated current to return, countermeasures like installation of a capacitor between power source and GND as the path for regenerated current needs to be taken. The capacitance value must be determined after it is adequately verified that there is no problem in properties such that the capacity of electrolytic capacitor goes down at low temperatures. Thermal design needs to allow adequate margin in consideration of allowable loss (Pd) in actual operation state.
- 5.) The GND pin needs to be at the lowest potential in any operation state.
- 6.) Thermal design needs to be done with adequate margin in consideration of allowable loss (Pd) in actual operation state.
- 7.) Use in a strong magnetic field may cause malfunction.
- 8.) Output Tr needs to not exceed the absolute maximum rating and ASO while using this IC. As CMOS IC and IC which has several power sources may undergo instant flow of rush current at turn-on, attention needs to be paid to the capacitance of power source coupling, power source, and the width and run length of GND wire pattern.
- 9.) This IC includes temperature protection circuit (TSD circuit). Temperature protection circuit (TSD circuit) strictly aims blockage of IC from thermal runaway, not protection or assurance of IC. Therefore use assuming continuous use and operation after this circuit is worked needs to not be done.
- 10.) As connection of a capacitor with a pin with low impedance at inspection of a set board may cause stress to IC, discharge needs to be performed every one process. Before a jig is connected to check a process, the power needs to be turned off absolutely. Before the jig is removed, as well, the power needs to be turned off.
- 11.) This IC is a monolithic IC which has P+ isolation for separation of elements and P board between elements. A P-N junction is formed in this P layer and N layer of elements, composing various parasitic elements. For example, a resistance and transistor are connected to a terminal as shown in the figure,
 - When GND>(Terminal A) in the resistance and when GND>(Terminal B) in the transistor (NPN), P-N junction operates as a parasitic diode.
 - When GND>(Terminal B) in the transistor (NPN), parasitic NPN transistor operates in N layer of other elements nearby the parasitic diode described before.

Parasitic elements are formed by the relation of potential inevitably in the structure of IC. Operation of parasitic elements can cause mutual interference among circuits, malfunction as well as damage. Therefore such use as will cause operation of parasitic elements like application of voltage on the input terminal lower than GND (P board) need to not be done.

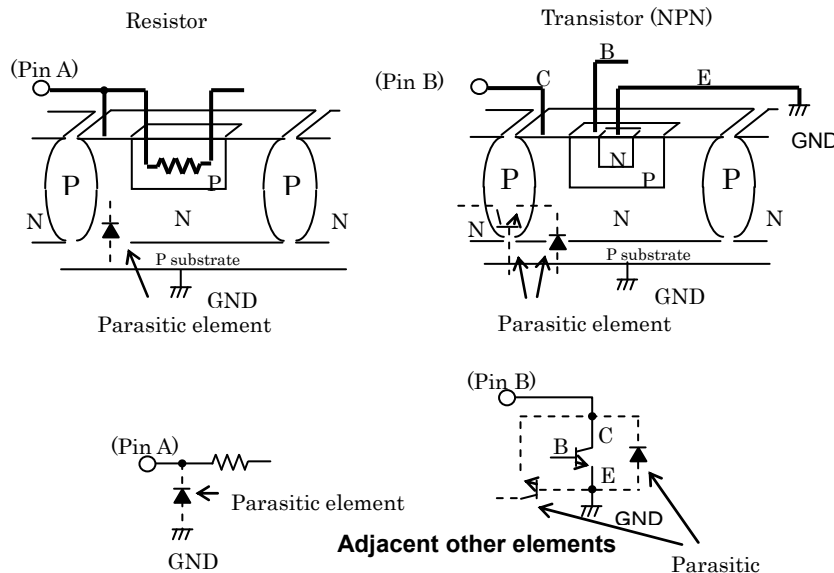

Figure 32. Example of Simple Structure of Monolithic IC

Status of this document

The Japanese version of this document is formal specification. A customer may use this translation version only for a reference to help reading the formal version.

If there are any differences in translation version of this document formal version takes priority.

●Ordering Information

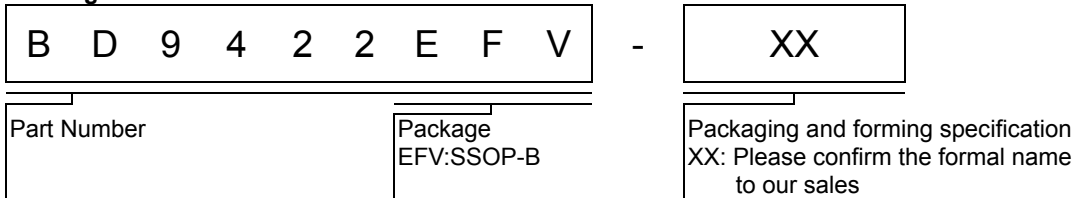

●Marking Diagram

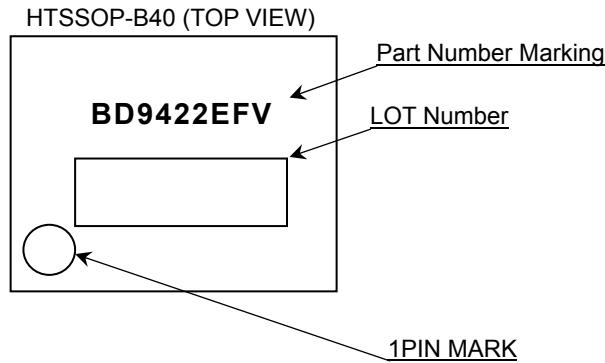

●Physical Dimension Tape and Reel Information

HTSSOP-B40

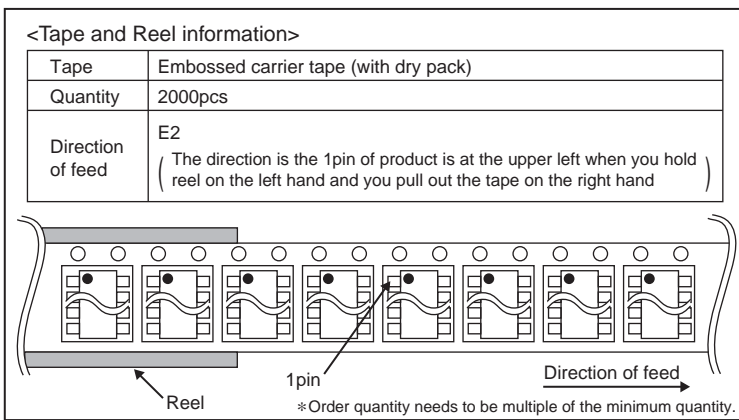
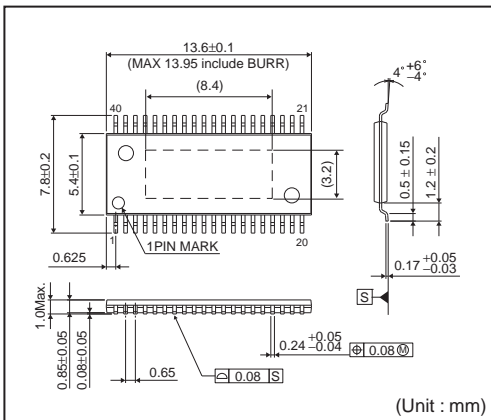

Revision History

Date	Revision	Changes
22.Sep.2012	001	Draft Version
6.Mar.2013	002	p.12 UVLO's explanation 2.4V→2.3V p.13 UVLO detection condition UVLO<2.4V→2.3V p.14 UVLO detection condition UVLO<2.4V→2.3V p.17 Equation of setting UVLO lock $V_{inlock}=2.4 \times \{ \rightarrow V_{inlock}=2.3 \times \{$ $1/530k+480k+40k) \times R1 \rightarrow 1/530k+480k+87k) \times R1$
9.Jun.2013	003	p.20 ●3.8 Timing chart modify FAIL logic
22.Dec.2014	004	p.2 Pin Configuration 37pin LPS→LSP
2.Jul.2015	005	p.14 ●3.3.2 List of the protection function modify table's contents
1.Sep.2015	006	p.13,14 The detailed timing condition for protections is added. p.15 ●3.4 Connecting operation of Master/ slave modify master/slave table p.17 ●3.5.9 How to set the UVLO 2.4V -> 2.3V

Notice

Precaution on using ROHM Products

- Our Products are designed and manufactured for application in ordinary electronic equipments (such as AV equipment, OA equipment, telecommunication equipment, home electronic appliances, amusement equipment, etc.). If you intend to use our Products in devices requiring extremely high reliability (such as medical equipment ^(Note 1), transport equipment, traffic equipment, aircraft/spacecraft, nuclear power controllers, fuel controllers, car equipment including car accessories, safety devices, etc.) and whose malfunction or failure may cause loss of human life, bodily injury or serious damage to property ("Specific Applications"), please consult with the ROHM sales representative in advance. Unless otherwise agreed in writing by ROHM in advance, ROHM shall not be in any way responsible or liable for any damages, expenses or losses incurred by you or third parties arising from the use of any ROHM's Products for Specific Applications.

(Note1) Medical Equipment Classification of the Specific Applications

JAPAN	USA	EU	CHINA
CLASS III	CLASS III	CLASS II b	CLASS III
CLASS IV		CLASS III	

- ROHM designs and manufactures its Products subject to strict quality control system. However, semiconductor products can fail or malfunction at a certain rate. Please be sure to implement, at your own responsibilities, adequate safety measures including but not limited to fail-safe design against the physical injury, damage to any property, which a failure or malfunction of our Products may cause. The following are examples of safety measures:
 - Installation of protection circuits or other protective devices to improve system safety
 - Installation of redundant circuits to reduce the impact of single or multiple circuit failure
- Our Products are designed and manufactured for use under standard conditions and not under any special or extraordinary environments or conditions, as exemplified below. Accordingly, ROHM shall not be in any way responsible or liable for any damages, expenses or losses arising from the use of any ROHM's Products under any special or extraordinary environments or conditions. If you intend to use our Products under any special or extraordinary environments or conditions (as exemplified below), your independent verification and confirmation of product performance, reliability, etc. prior to use, must be necessary:
 - Use of our Products in any types of liquid, including water, oils, chemicals, and organic solvents
 - Use of our Products outdoors or in places where the Products are exposed to direct sunlight or dust
 - Use of our Products in places where the Products are exposed to sea wind or corrosive gases, including Cl₂, H₂S, NH₃, SO₂, and NO₂
 - Use of our Products in places where the Products are exposed to static electricity or electromagnetic waves
 - Use of our Products in proximity to heat-producing components, plastic cords, or other flammable items
 - Sealing or coating our Products with resin or other coating materials
 - Use of our Products without cleaning residue of flux (even if you use no-clean type fluxes, cleaning residue of flux is recommended); or Washing our Products by using water or water-soluble cleaning agents for cleaning residue after soldering
 - Use of the Products in places subject to dew condensation
- The Products are not subject to radiation-proof design.
- Please verify and confirm characteristics of the final or mounted products in using the Products.
- In particular, if a transient load (a large amount of load applied in a short period of time, such as pulse. is applied, confirmation of performance characteristics after on-board mounting is strongly recommended. Avoid applying power exceeding normal rated power; exceeding the power rating under steady-state loading condition may negatively affect product performance and reliability.
- De-rate Power Dissipation (Pd) depending on Ambient temperature (Ta). When used in sealed area, confirm the actual ambient temperature.
- Confirm that operation temperature is within the specified range described in the product specification.
- ROHM shall not be in any way responsible or liable for failure induced under deviant condition from what is defined in this document.

Precaution for Mounting / Circuit board design

- When a highly active halogenous (chlorine, bromine, etc.) flux is used, the residue of flux may negatively affect product performance and reliability.
- In principle, the reflow soldering method must be used on a surface-mount products, the flow soldering method must be used on a through hole mount products. If the flow soldering method is preferred on a surface-mount products, please consult with the ROHM representative in advance.

For details, please refer to ROHM Mounting specification

Precautions Regarding Application Examples and External Circuits

1. If change is made to the constant of an external circuit, please allow a sufficient margin considering variations of the characteristics of the Products and external components, including transient characteristics, as well as static characteristics.
2. You agree that application notes, reference designs, and associated data and information contained in this document are presented only as guidance for Products use. Therefore, in case you use such information, you are solely responsible for it and you must exercise your own independent verification and judgment in the use of such information contained in this document. ROHM shall not be in any way responsible or liable for any damages, expenses or losses incurred by you or third parties arising from the use of such information.

Precaution for Electrostatic

This Product is electrostatic sensitive product, which may be damaged due to electrostatic discharge. Please take proper caution in your manufacturing process and storage so that voltage exceeding the Products maximum rating will not be applied to Products. Please take special care under dry condition (e.g. Grounding of human body / equipment / solder iron, isolation from charged objects, setting of Ionizer, friction prevention and temperature / humidity control).

Precaution for Storage / Transportation

1. Product performance and soldered connections may deteriorate if the Products are stored in the places where:
 - [a] the Products are exposed to sea winds or corrosive gases, including Cl₂, H₂S, NH₃, SO₂, and NO₂
 - [b] the temperature or humidity exceeds those recommended by ROHM
 - [c] the Products are exposed to direct sunshine or condensation
 - [d] the Products are exposed to high Electrostatic
2. Even under ROHM recommended storage condition, solderability of products out of recommended storage time period may be degraded. It is strongly recommended to confirm solderability before using Products of which storage time is exceeding the recommended storage time period.
3. Store / transport cartons in the correct direction, which is indicated on a carton with a symbol. Otherwise bent leads may occur due to excessive stress applied when dropping of a carton.
4. Use Products within the specified time after opening a humidity barrier bag. Baking is required before using Products of which storage time is exceeding the recommended storage time period.

Precaution for Product Label

QR code printed on ROHM Products label is for ROHM's internal use only.

Precaution for Disposition

When disposing Products please dispose them properly using an authorized industry waste company.

Precaution for Foreign Exchange and Foreign Trade act

Since concerned goods might be fallen under listed items of export control prescribed by Foreign exchange and Foreign trade act, please consult with ROHM in case of export.

Precaution Regarding Intellectual Property Rights

1. All information and data including but not limited to application example contained in this document is for reference only. ROHM does not warrant that foregoing information or data will not infringe any intellectual property rights or any other rights of any third party regarding such information or data.
2. ROHM shall not have any obligations where the claims, actions or demands arising from the combination of the Products with other articles such as components, circuits, systems or external equipment (including software).
3. No license, expressly or implied, is granted hereby under any intellectual property rights or other rights of ROHM or any third parties with respect to the Products or the information contained in this document. Provided, however, that ROHM will not assert its intellectual property rights or other rights against you or your customers to the extent necessary to manufacture or sell products containing the Products, subject to the terms and conditions herein.

Other Precaution

1. This document may not be reprinted or reproduced, in whole or in part, without prior written consent of ROHM.
2. The Products may not be disassembled, converted, modified, reproduced or otherwise changed without prior written consent of ROHM.
3. In no event shall you use in any way whatsoever the Products and the related technical information contained in the Products or this document for any military purposes, including but not limited to, the development of mass-destruction weapons.
4. The proper names of companies or products described in this document are trademarks or registered trademarks of ROHM, its affiliated companies or third parties.

General Precaution

1. Before you use our Products, you are requested to carefully read this document and fully understand its contents. ROHM shall not be in any way responsible or liable for failure, malfunction or accident arising from the use of any ROHM's Products against warning, caution or note contained in this document.
2. All information contained in this document is current as of the issuing date and subject to change without any prior notice. Before purchasing or using ROHM's Products, please confirm the latest information with a ROHM sales representative.
3. The information contained in this document is provided on an "as is" basis and ROHM does not warrant that all information contained in this document is accurate and/or error-free. ROHM shall not be in any way responsible or liable for any damages, expenses or losses incurred by you or third parties resulting from inaccuracy or errors of or concerning such information.

Данный компонент на территории Российской Федерации

Вы можете приобрести в компании MosChip.

Для оперативного оформления запроса Вам необходимо перейти по данной ссылке:

<http://moschip.ru/get-element>

Вы можете разместить у нас заказ для любого Вашего проекта, будь то серийное производство или разработка единичного прибора.

В нашем ассортименте представлены ведущие мировые производители активных и пассивных электронных компонентов.

Нашей специализацией является поставка электронной компонентной базы двойного назначения, продукции таких производителей как XILINX, Intel (ex.ALTERA), Vicor, Microchip, Texas Instruments, Analog Devices, Mini-Circuits, Amphenol, Glenair.

Сотрудничество с глобальными дистрибьюторами электронных компонентов, предоставляет возможность заказывать и получать с международных складов практически любой перечень компонентов в оптимальные для Вас сроки.

На всех этапах разработки и производства наши партнеры могут получить квалифицированную поддержку опытных инженеров.

Система менеджмента качества компании отвечает требованиям в соответствии с ГОСТ Р ИСО 9001, ГОСТ РВ 0015-002 и ЭС РД 009

Офис по работе с юридическими лицами:

105318, г.Москва, ул.Щербаковская д.3, офис 1107, 1118, ДЦ «Щербаковский»

Телефон: +7 495 668-12-70 (многоканальный)

Факс: +7 495 668-12-70 (доб.304)

E-mail: info@moschip.ru

Skype отдела продаж:

moschip.ru

moschip.ru_4

moschip.ru_6

moschip.ru_9