

RoHS COMPLIANT

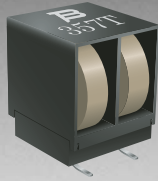

BOURNS®

Features

- Two resistance-matched PTCs in a plastic housing
- Narrow resistance tolerance
- RoHS compliant*

Applications

Used as a secondary overcurrent protection device in:

- Customer Premise Equipment (CPE)
- Central Office (CO)
- Access equipment

CMF-SDP Series - Telecom CPTC Resettable Fuses

Electrical Characteristics

Model	Induction Voltage Withstand	Rated Voltage	Rated Resistance (RN)		Resistance Matching In Housing	Hold Current	Trip Current	Imax @ 230 VAC	Typical Time to Trip @ Imax/ 230 VAC
	VAC		Volts	Ohms	Tolerance				Ohms
CMF-SDP07	600	230	7	±20 %	±0.5	0.150	0.350	3.0	0.45
CMF-SDP10	600	230	10	±20 %	±0.5	0.180	0.360	1.0	3.8
CMF-SDP10A	600	230	10	±20 %	±0.5	0.150	0.360	1.0	3.8
CMF-SDP25	600	230	25	±20 %	±0.5	0.130	0.260	2.8	0.2
CMF-SDP25A	600	230	25	±20 %	±0.5	0.130	0.260	2.8	0.3
CMF-SDP35	600	230	35	+15/-20 %	±0.5	0.110	0.230	4.6	0.06
CMF-SDP35A	600	230	35	+15/-20 %	±0.5	0.110	0.230	4.6	0.04
CMF-SDP50	600	230	50	±15 %	±0.5	0.090	0.190	2.5	0.13
CMF-SDP50A	600	230	50	±15 %	±0.5	0.090	0.190	2.5	0.1
CMF-SDP75	600	230	75	±20 %	±1	0.070	0.150	2.5	0.12

Operating Temperature Range: -40°C to +125 °C

Test Procedures And Requirements For Model CMF-SDP Series

Test	Primary Protection	Test Condition	Requirements
Mains Power Contact - ITU-T K.20, K.21	None	230 V rms, 10 ohms, 15 Min.	(Ri-Rf) / Ri < ±10 %
Power Induction - ITU-T K.20, K.21	None	600V rms, 600 ohms, 0.2 seconds, 10 cycles, every 1 Min.	(Ri-Rf) / Ri < ±10 %
Power Induction - ITU-T K.20, K.21	GDT	600 V rms, 600 ohms, 1 second, 10 cycles, every 1 Min.	(Ri-Rf) / Ri < ±10 %
Power Induction - ITU-T K.20, K.21	GDT	600 V rms, 200 ohms, 1 second, 10 cycles, every 1 Min.	(Ri-Rf) / Ri < ±10 %
Lightning Surge - ITU-T K.20, K.21		10/700 μs, 25 ohms, 1.0 kV, 10 Tests, every 1 Min.	(Ri-Rf) / Ri < ±10 %
Lightning Surge		10/100 μs, 25 ohms, 1.5 kV, 30 Tests, every 3 Min.	(Ri-Rf) / Ri < ±10 %

Ri = R initial
Rf = R final

Typical Part Marking

Represents total content. Layout may vary.

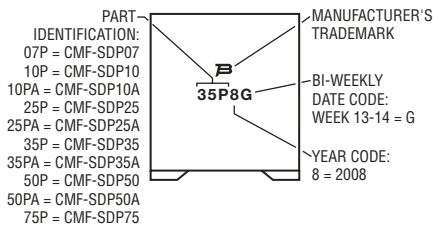

How to Order

CMF - SD P 35 A -XX - 2

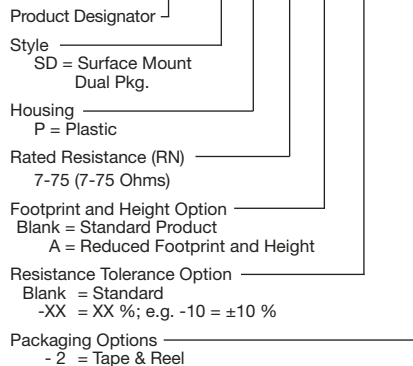

Asia-Pacific:
Tel: +886-2 2562-4117
Fax: +886-2 2562-4116

Europe:
Tel: +41-41 768 5555
Fax: +41-41 768 5510

The Americas:
Tel: +1-951 781-5500
Fax: +1-951 781-5700
www.bourns.com

*RoHS Directive 2002/95/EC Jan 27 2003 including Annex.
Specifications are subject to change without notice.
Customers should verify actual device performance in their specific applications.

CMF-SDP Series - Telecom CPTC Resettable Fuses



Solder Reflow Recommendations

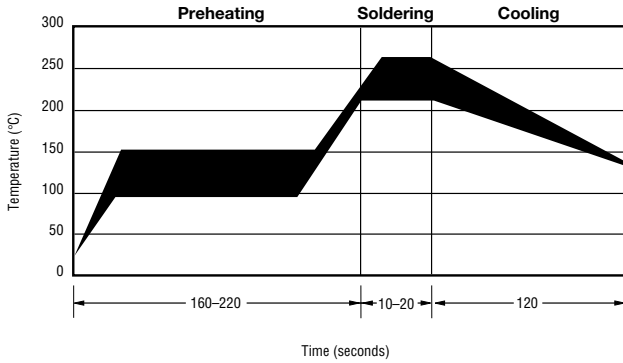

Solder reflow

- Recommended reflow methods: IR, vapor phase oven, hot air oven.
- Devices are not designed to be wave soldered to the bottom side of the board.
- Gluing the devices is not recommended.
- Recommended maximum paste thickness is 0.25 mm (.010 inch).
- Devices can be cleaned using standard industry methods and solvents.

Note:

- If reflow temperatures exceed the recommended profile, devices may not meet the performance specifications.

Rework

- A device should not be reworked.

Product Dimensions

CMF-SDP07, 10, 25, 35, 50 & 75

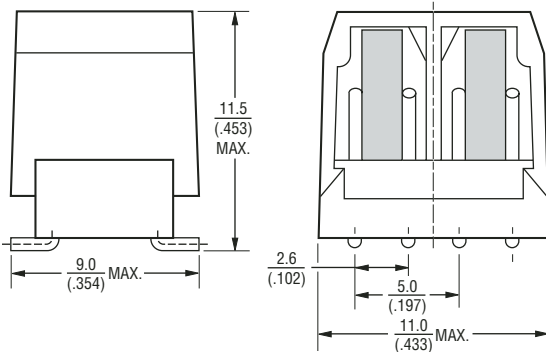

CMF-SDP10A, 25A, 35A & 50A

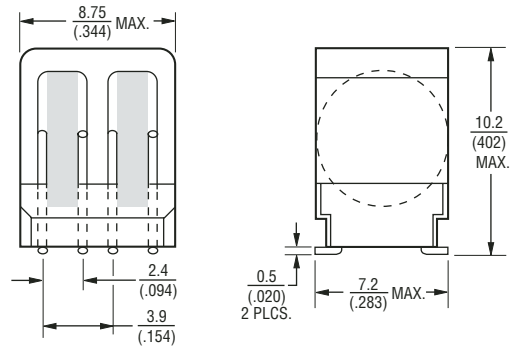

Recommended Pad Layout

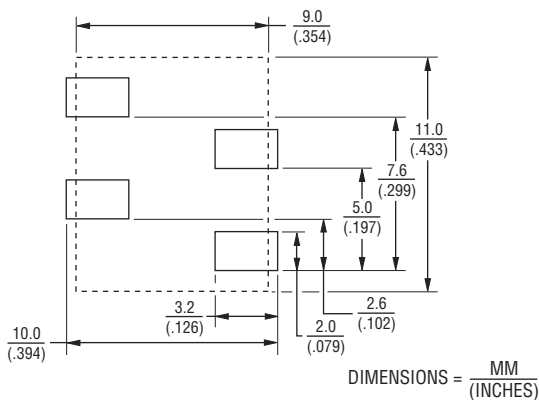

Packaging options: TAPE & REEL: 350 pcs. per reel

Recommended Pad Layout

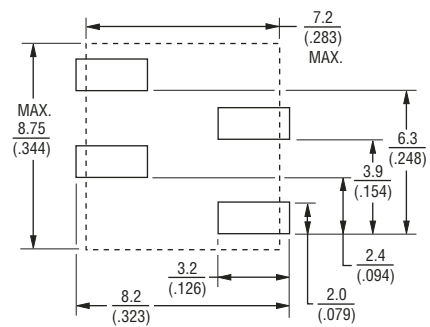

Packaging options: TAPE & REEL: 400 pcs. per reel

CMF-SDP Series Tape and Reel Specifications

BOURNS®

Tape Dimensions per EIA 481-2

CMF-SDP10-2, CMF-SDP25-2,
CMF-SDP-35-2, CMF-SDP50-2,
CMF-SDP75-2

CMF-SDP10A-2, CMF-SDP25A-2,
CMF-SDP35A-2, CMF-SDP50A-2

W	$\frac{24.0 \pm 0.5}{(0.945 \pm 0.020)}$	$\frac{24.0 \pm 0.5}{(0.945 \pm 0.020)}$
P ₀	$\frac{4.0}{(0.157)}$	$\frac{4.0}{(0.157)}$
P	$\frac{16.0}{(0.630)}$	$\frac{16.0}{(0.630)}$
P ₂	$\frac{2.0}{(0.079)}$	$\frac{2.0}{(0.079)}$
A ₀	$\frac{9.1 \pm 0.2}{(0.358 \pm 0.008)}$	$\frac{7.5 \pm 0.2}{(0.295 \pm 0.008)}$
B ₀	$\frac{11.20 \pm 0.2}{(0.441 \pm 0.008)}$	$\frac{9.0 \pm 0.2}{(0.354 \pm 0.008)}$
D	$\frac{1.5}{(0.059)}$	$\frac{1.5}{(0.059)}$
F	$\frac{11.5}{(0.453)}$	$\frac{11.5}{(0.453)}$
E	$\frac{1.75}{(0.069)}$	$\frac{1.75}{(0.069)}$
t	$\frac{0.5 \pm 0.15}{(0.020 \pm 0.006)}$	$\frac{0.5 \pm 0.15}{(0.020 \pm 0.006)}$
K ₀	$\frac{11.7 \pm 0.2}{(0.433 \pm 0.008)}$	$\frac{10.0 \pm 0.2}{(0.394 \pm 0.008)}$

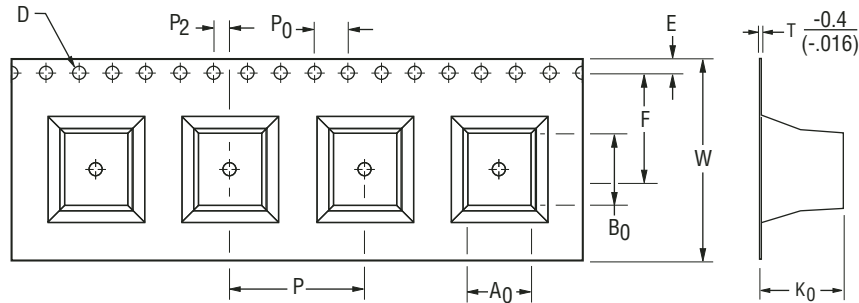

DIMENSIONS = $\frac{\text{MM}}{\text{(INCHES)}}$

Specifications are subject to change without notice.
Customers should verify actual device performance in their specific applications.

Данный компонент на территории Российской Федерации

Вы можете приобрести в компании MosChip.

Для оперативного оформления запроса Вам необходимо перейти по данной ссылке:

<http://moschip.ru/get-element>

Вы можете разместить у нас заказ для любого Вашего проекта, будь то серийное производство или разработка единичного прибора.

В нашем ассортименте представлены ведущие мировые производители активных и пассивных электронных компонентов.

Нашей специализацией является поставка электронной компонентной базы двойного назначения, продукции таких производителей как XILINX, Intel (ex.ALTERA), Vicor, Microchip, Texas Instruments, Analog Devices, Mini-Circuits, Amphenol, Glenair.

Сотрудничество с глобальными дистрибьюторами электронных компонентов, предоставляет возможность заказывать и получать с международных складов практически любой перечень компонентов в оптимальные для Вас сроки.

На всех этапах разработки и производства наши партнеры могут получить квалифицированную поддержку опытных инженеров.

Система менеджмента качества компании отвечает требованиям в соответствии с ГОСТ Р ИСО 9001, ГОСТ РВ 0015-002 и ЭС РД 009

Офис по работе с юридическими лицами:

105318, г.Москва, ул.Щербаковская д.3, офис 1107, 1118, ДЦ «Щербаковский»

Телефон: +7 495 668-12-70 (многоканальный)

Факс: +7 495 668-12-70 (доб.304)

E-mail: info@moschip.ru

Skype отдела продаж:

moschip.ru

moschip.ru_4

moschip.ru_6

moschip.ru_9