

DS9097U Universal 1-Wire COM Port Adapter

FEATURES

- True-Ground Interface to an RS-232 COM Port for Reading and Writing 1-Wire® Devices
- Works with Bipolar as well as Unipolar Logic Signals
- Compatible to COM port of (±)5V to (±)12V (DB9 Version Only) or (±)6V to (±)12V (DB25 Version)
- Supports Reading and Writing at Standard and Overdrive Speeds
- Provides Strong Pullup to 5V for Temperature and EEPROM 1-Wire Devices
- Programs 1-Wire EPROM Devices (DB-25 Version with External 12V Power Supply Only)
- Communicates at Data Rates of 9.6kbps (default), 19.2kbps, 57.6kbps, and 115.2kbps
- Standard DB9 or DB25 Female Connector and 6-Lead RJ11 Connector for Easy Attachment of Standard 1-Wire Cables and Probes
- Includes DS2502 Identification Chip (DS9097U-009 Only)

PIN ASSIGNMENT

DB9: TXD (3), RXD (2), DTR (4), RTS (7), PC-Ground (5); all other pins not connected

DB25: TXD (2), RXD (3), DTR (20), RTS (4), PC-Ground (7); all other pins not connected

Note 1: The external supply for the DS9097U-E25 must provide well-regulated 12V at 10mA minimum, center = GND, outer ring = V+ (Newark Electronics Stock No. 84F2081, Allied Electronics Stock No. 928-9895, Stancor Model STA-300R, or equivalent).

Note 2: The color of the DS9097U plastic case can vary.

ORDERING INFORMATION

PART	TYPE
DS9097U-009#	DB9, with DS2502 ID chip
DS9097U-S09#	DB9, no ID chip
DS9097U-E25#	DB25, with EPROM write

#Denotes a RoHS-compliant device that may include lead(Pb) that is exempt under the RoHS requirements.

1-Wire is a registered trademark of Maxim Integrated Products, Inc.

PACKAGE OUTLINE

DB9 VERSION

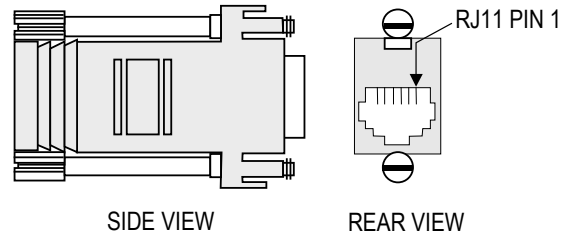

DB25 VERSION

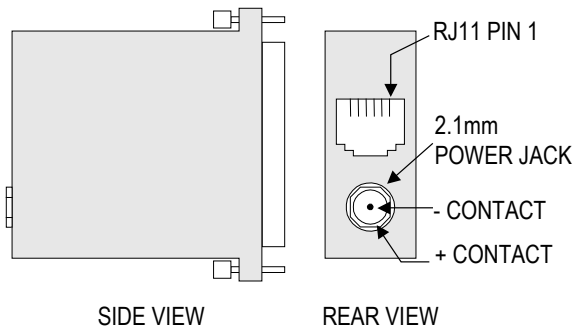

SCHEMATIC (FOR ILLUSTRATION)

DB9 VERSION

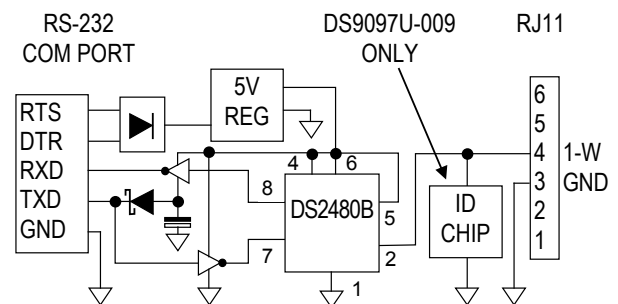

DB25 VERSION

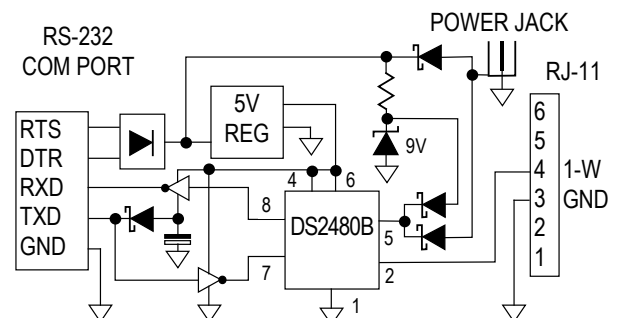

For pricing, delivery, and ordering information, please contact Maxim Direct at 1-888-629-4642, or visit Maxim's website at www.maximintegrated.com.

DESCRIPTION

The DS9097U is a sophisticated RS-232 to 1-Wire adapter, which performs RS-232 level conversion and actively generates the 1-Wire communication signals. Together with an adequate software driver, it enables a Windows®-based PC to directly communicate with any 1-Wire device connected to the adapter's RJ11 port. The DB9 version reads and writes any non-EEPROM 1-Wire device. To write to EEPROM devices, the DB25 version with external power supply is required. For a list of suitable 1-Wire network cables, refer to the *Connectivity Matrix* table in the DS1402x 1-Wire network cables data sheet.

All DS9097U adapters are based on the DS2480B serial 1-Wire line driver chip. The RXD/TXD polarity select input of the DS2480B is connected to V_{DD} (noninverting).

Free software drivers can be downloaded from www.maxim-ic.com/1-Wiredrivers.

The DS9097U communicates with 1-Wire devices at standard speed as well as overdrive speed. The serial port must support a data transmission rate of 9600bps. Under software control, the adapter can be set up for RS-232 data rates of 19200bps, 57600bps, and 115200bps. The two higher rates are recommended for communication at overdrive speed with overdrive-capable devices. Since the DS9097U operates in a byte mode, every data byte received from the RS-232 port generates eight time slots on the 1-Wire line.

Note that there are some COM ports that use signal levels of less than (\pm) 5V. The DB9 versions of this adapter do not work with such ports. The DS9097U-E25 adapter, however, functions in most cases if external power is supplied. Without EEPROM programming, the external power can be anywhere in the range of 6V to 9V. For EEPROM programming the voltage must be at 12V in any case. Before using an externally powered DS9097U-E25 with a COM port of less than (\pm) 5V, check whether the COM port will not be damaged by 5V on its RXD input.

Windows is a registered trademark of Microsoft Corp.

REVISION HISTORY

REVISION DATE	DESCRIPTION	PAGES CHANGED
9/00	Initial release	—
2/04	Updated for change in plastic body style; added note that the color of the plastic body may vary	1
8/09	Added the # sign to all the part numbers in the <i>Ordering Information</i> table; added the <i>Revision History</i> table	1, 3
6/11	Deleted references to Crypto devices, TMEX, DS9097, and DS9097E; added reference to the <i>Connectivity Matrix</i> table in the DS1402x 1-Wire network cables data sheet; updated the URL for software drivers download	1, 2



Maxim cannot assume responsibility for use of any circuitry other than circuitry entirely embodied in a Maxim product. No circuit patent licenses are implied. Maxim reserves the right to change the circuitry and specifications without notice at any time. The parametric values (min and max limits) shown in the Electrical Characteristics table are guaranteed. Other parametric values quoted in this data sheet are provided for guidance.

Maxim Integrated 160 Rio Robles, San Jose, CA 95134 USA 1-408-601-1000

3

Данный компонент на территории Российской Федерации

Вы можете приобрести в компании MosChip.

Для оперативного оформления запроса Вам необходимо перейти по данной ссылке:

<http://moschip.ru/get-element>

Вы можете разместить у нас заказ для любого Вашего проекта, будь то серийное производство или разработка единичного прибора.

В нашем ассортименте представлены ведущие мировые производители активных и пассивных электронных компонентов.

Нашей специализацией является поставка электронной компонентной базы двойного назначения, продукции таких производителей как XILINX, Intel (ex.ALTERA), Vicor, Microchip, Texas Instruments, Analog Devices, Mini-Circuits, Amphenol, Glenair.

Сотрудничество с глобальными дистрибьюторами электронных компонентов, предоставляет возможность заказывать и получать с международных складов практически любой перечень компонентов в оптимальные для Вас сроки.

На всех этапах разработки и производства наши партнеры могут получить квалифицированную поддержку опытных инженеров.

Система менеджмента качества компании отвечает требованиям в соответствии с ГОСТ Р ИСО 9001, ГОСТ РВ 0015-002 и ЭС РД 009

Офис по работе с юридическими лицами:

105318, г.Москва, ул.Щербаковская д.3, офис 1107, 1118, ДЦ «Щербаковский»

Телефон: +7 495 668-12-70 (многоканальный)

Факс: +7 495 668-12-70 (доб.304)

E-mail: info@moschip.ru

Skype отдела продаж:

moschip.ru

moschip.ru_4

moschip.ru_6

moschip.ru_9