

“Ultra-Mini” SiSonic™ Microphone Specification With MaxRF Protection – *Halogen Free*

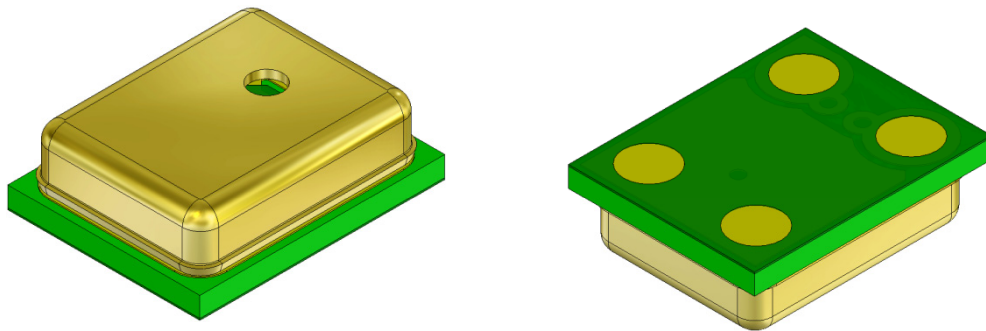

Knowles Acoustics
1151 Maplewood Drive
Itasca, IL 60143

1. DESCRIPTION AND APPLICATION

1.1 Description

“Ultra Mini” Surface Mount Silicon Microphone with
Maximum RF Protection – *Halogen Free*

1.2 Application

Hand held consumer electronics

2. PART MARKING

Identification Number Convention

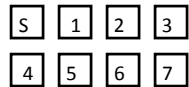

S: Manufacturing Location

“S” – Knowles Electronics Suzhou
Suzhou, China

“No Alpha Character” – Knowles Electronics Itasca
Itasca, IL USA

“E” – Engineering Samples

Digits 1 – 7: Job Identification Number

3. TEMPERATURE RANGE

3.1 Operating Temperature Range: -40°C to +100°C

3.2 Storage Temperature Range: -40°C to +100°C

4. ACOUSTIC & ELECTRICAL SPECIFICATIONS

	Symbol	Condition	Limits			Unit
			Min.	Nom.	Max.	
Directivity		Omni-directional				
Sensitivity	S	@ 1kHz (0dB=1V/Pa)	-45	-42	-39	dB
Output impedance	Z _{OUT}	@ 1kHz (0dB=1V/Pa)	---	---	300	Ω
Current Consumption	I _{DSS}	across 1.5 to 3.6 volts	---	---	250	μA
Signal to Noise Ratio	S/N	@ 1kHz (0dB=1V/Pa)	---	59	---	dB
Supply Voltage	V _s		1.5	---	3.6	V
Sensitivity Loss across Voltage		Change in sensitivity over 3.6v to 1.5v	No Change Across Voltage Range			dB
THD		At 100dB SPL, THD < 1% At 115dB SPL, THD < 10%				dB

5. FREQUENCY RESPONSE CURVE

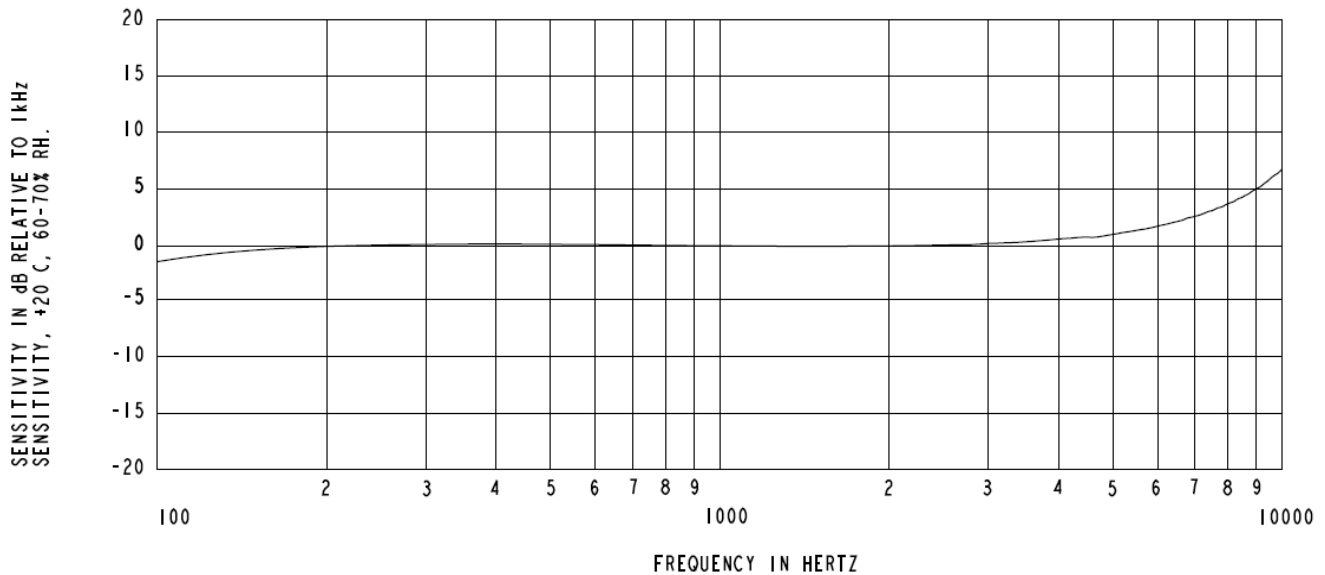

6. MECHANICAL SPECIFICATIONS

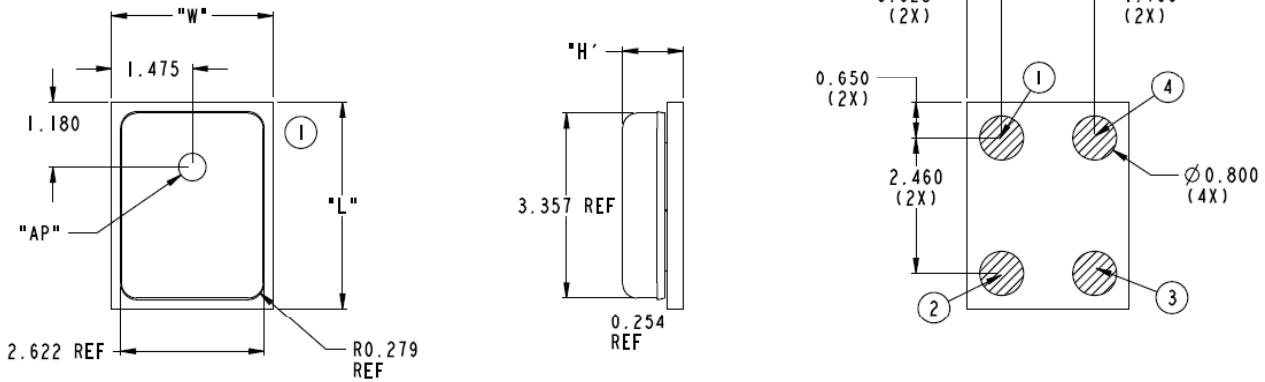

ITEM	DIMENSION	TOLERANCE	UNITS
HEIGHT (H)	1.100	±0.10	mm
LENGTH (L)	3.760	±0.10	mm
WIDTH (W)	2.950	±0.10	mm
ACOUSTIC PORT (AP)	∅ 0.500	±0.10	mm

PIN OUTPUT	
PIN #	FUNCTION
1	POWER (V _{dd})
2	GROUND
3	GROUND
4	OUTPUT

NOTES:

1. DIMENSIONS IN MILLIMETERS UNLESS OTHERWISE SPECIFIED.
2. TOLERANCE ±0.15mm UNLESS OTHERWISE SPECIFIED.

7. RECOMMENDED CUSTOMER LAND PATTERN

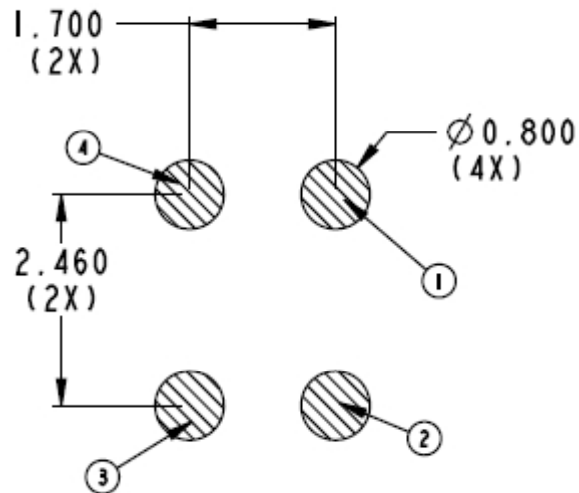

8. RECOMMENDED SOLDER STENCIL PATTERN

N/A

9. RECOMMENDED INTERFACE CIRCUIT

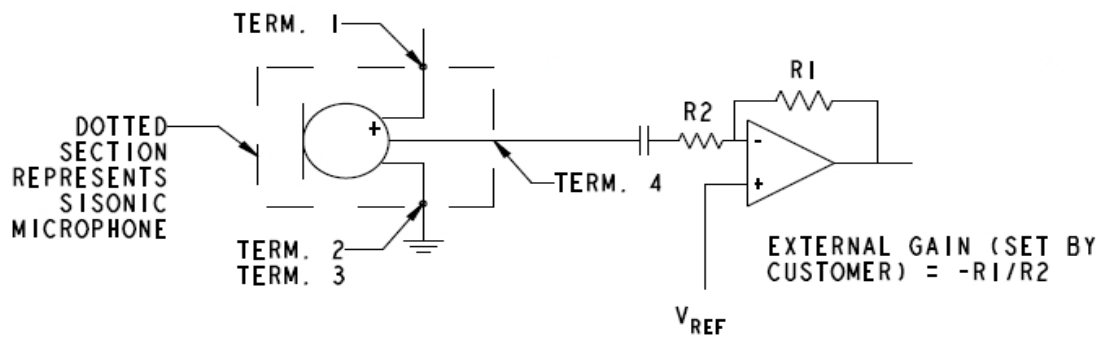

10. PACKAGING DETAIL

ITEM	DIMENSION (MM [INCH])	TOLERANCE (MM [INCH])
A ₀	4.16	±0.10
B ₀	3.40	±0.10
K ₀	1.30	±0.10
L _p	8.00	±0.10
L _s	4.00	±0.20 OVER 10 HOLES
L ₀	2.00	±0.05
W _T	12.00	±0.30
W _p	5.50	±0.05
W _s	1.75	±0.10
T	0.30	±0.05
D _p	∅1.50	+0.10/-0
D _s	∅1.50	+0.10/-0
D _c	∅1.0	±0.05

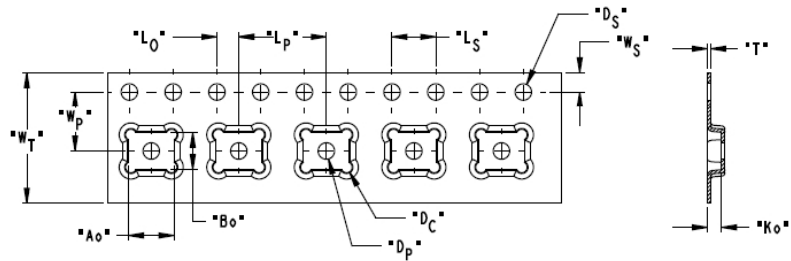

TRACKING NUMBER CONVENTION
 X = MANUFACTURING LOCATION
 (ALPHA CHARACTER)
 Y = JOB IDENTIFICATION
 NUMBER (JIN)
 (NUMERIC CHARACTER)
MANUFACTURING LOCATION
 S = SUZHOU, CHINA
 E = ENGINEERING SAMPLES

MODEL NUMBER	SUFFIX	REEL DIAMETER	QUANTITY PER REEL
SPU0410HR5H-PB	-2	7"	1,200
SPU0410HR5H-PB	-7	13"	5,700

TAPE & REEL	PER EIA-481
LABEL	LABEL APPLIED TO EXTERNAL PACKAGE AND DIRECT TO REEL.

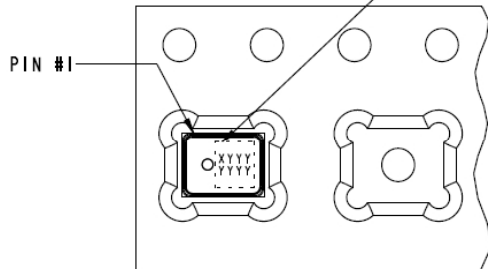

11. SOLDER REFLOW PROFILE

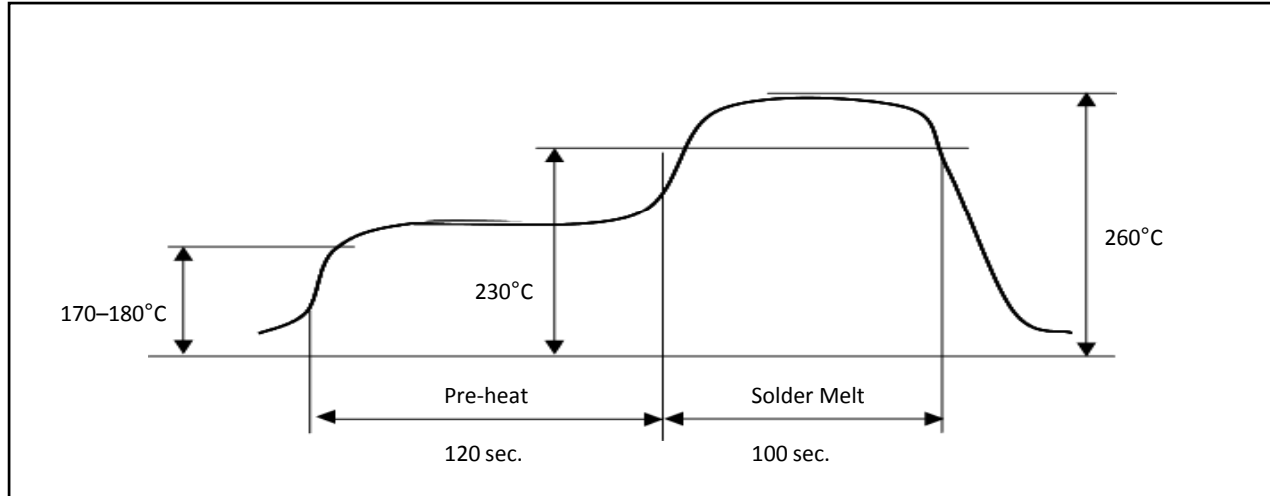

<u>Stage</u>	<u>Temperature Profile</u>	<u>Time (maximum)</u>
Pre-heat	170 ~ 180 C	120 sec.
Solder Melt	Above 230 C	100 sec.
Peak	260 C maximum	30 sec.

Notes:

1. Do not pull a vacuum over the port hole of the microphone. Pulling a vacuum over the port hole can damage the device.
2. Do not board wash after the reflow process. Board washing and cleaning agents can damage the device. Do not expose to ultrasonic processing or cleaning.
3. Number of Reflow = recommend no more than 3 cycles.

12. ADDITIONAL NOTES

- (A) Shelf life: Twelve (12) months when devices are to be stored in factory supplied, unopened ESD moisture sensitive bag under maximum environmental conditions of 30°C, 70% R.H.
- (B) MSL (moisture sensitivity level) Class 2a.

13. RELIABILITY SPECIFICATIONS

Note: After test conditions are performed, the sensitivity of the microphone shall not deviate more than 3dB from its initial value.

Test	Description
Thermal Shock	100 cycles of air-air thermal shock from -40C to +125C with 15min soaks. (ICE 68-2-4)
High Temperature Storage	+105C environment for 1,000 hours. (IEC 68-2-2 Test Ba)
Low Temperature Storage	-40C environment for 1,000 hours. (IEC 68-2-2 Test Aa)
High Temperature Bias	+105C environment while under bias for 1,000 hours. (IEC 68-2-2 Test Ba)
Low Temperature Bias	-40C environment while under bias for 1,000 hours. (IEC 68-2-2 Test Aa)
Temperature / Humidity Bias	+85C/85% RH environment while under bias for 500 hours. (JESD22-A101A-B)
Vibration	4 cycles lasting 12 minutes from 20 to 2,000Hz in X, Y, and Z direction with a peak acceleration of 20g. (MIL 883E, Method 2007.2, A)
Electrostatic Discharge	3 discharges at +/- 8kV direct contact to the lid when unit is grounded (IEC 61000-4-2) and 3 discharges at +/- 2kV direct contact to the I/O pins (MIL 883E, Method 3015.7)
Reflow	5 reflow cycles with peak temperature of 260C.
Mechanical Shock	3 pulses of 10,000g in the X, Y, and Z direction. (IEC 68-2-27, Test Ea)

Данный компонент на территории Российской Федерации

Вы можете приобрести в компании MosChip.

Для оперативного оформления запроса Вам необходимо перейти по данной ссылке:

<http://moschip.ru/get-element>

Вы можете разместить у нас заказ для любого Вашего проекта, будь то серийное производство или разработка единичного прибора.

В нашем ассортименте представлены ведущие мировые производители активных и пассивных электронных компонентов.

Нашей специализацией является поставка электронной компонентной базы двойного назначения, продукции таких производителей как XILINX, Intel (ex.ALTERA), Vicor, Microchip, Texas Instruments, Analog Devices, Mini-Circuits, Amphenol, Glenair.

Сотрудничество с глобальными дистрибьюторами электронных компонентов, предоставляет возможность заказывать и получать с международных складов практически любой перечень компонентов в оптимальные для Вас сроки.

На всех этапах разработки и производства наши партнеры могут получить квалифицированную поддержку опытных инженеров.

Система менеджмента качества компании отвечает требованиям в соответствии с ГОСТ Р ИСО 9001, ГОСТ РВ 0015-002 и ЭС РД 009

Офис по работе с юридическими лицами:

105318, г.Москва, ул.Щербаковская д.3, офис 1107, 1118, ДЦ «Щербаковский»

Телефон: +7 495 668-12-70 (многоканальный)

Факс: +7 495 668-12-70 (доб.304)

E-mail: info@moschip.ru

Skype отдела продаж:

moschip.ru

moschip.ru_4

moschip.ru_6

moschip.ru_9