

M21328 HD/SD and 2xHD-SDI Cable Driver

The M21328 is a high-speed, low-power, low-jitter cable drivers. It is designed to drive serial digital video data through 75Ω coaxial cable typically used in SMPTE and DVB-ASI video applications. The M21328 cable driver is optimized for performance from 143 Mbps up to 2970 Mbps. It has selectable slew rates for SD-SDI and HD-SDI applications.

The typical output rise/fall time of the M21328 is 100 ps for HD and 2xHD rates. It has a typical set slew rate of 600 ps at SD rates. The default output voltage swing is compliant with SMPTE 292M, 259M, 344M and 424M using a 750Ω ±1% resistor. The M21328 supports a maximum single ended output swing of 1600 mVp-p, when configured appropriately.

The M21328 device is packaged in a new high performance 4x4 mm MLF package to simplify the PCB and reduce package parasitics with resulting improvements in Output Return Loss (ORL). It is available in an RoHS compliant package, that is backwards compatible with standard JEDEC SnPb processes.

The M21328 is pin compatible with the GS2978. It will also fit the footprint of the GS1578/1578A, but with the added feature of an Output Disable control pin.

Applications

- Serial Routing Switchers,
- Production/Master Control Switchers
- Distribution Amplifiers
- Video Tape Recorders, ENG Edit decks, Cameras
- Broadcast video applications
- NLE's, MPEG Encoders/Decoders, format convertors etc.

Standards Compliance

- SMPTE 292M, 259M, 344M, 424M
- DVB-ASI

Features

- 2xHD, HD and SD operation
- 800 mVp-p single ended output swing (typical)
- 1600 mVp-p maximum single ended output swing
- SD/HD Slew Rate control
- 3.3V Supply
- Low P_{DISS} (144 mW @ 3.3V)
- Extended temp. range: -10 to 85°C
- RoHS package
- Output disable

Functional Block Diagram

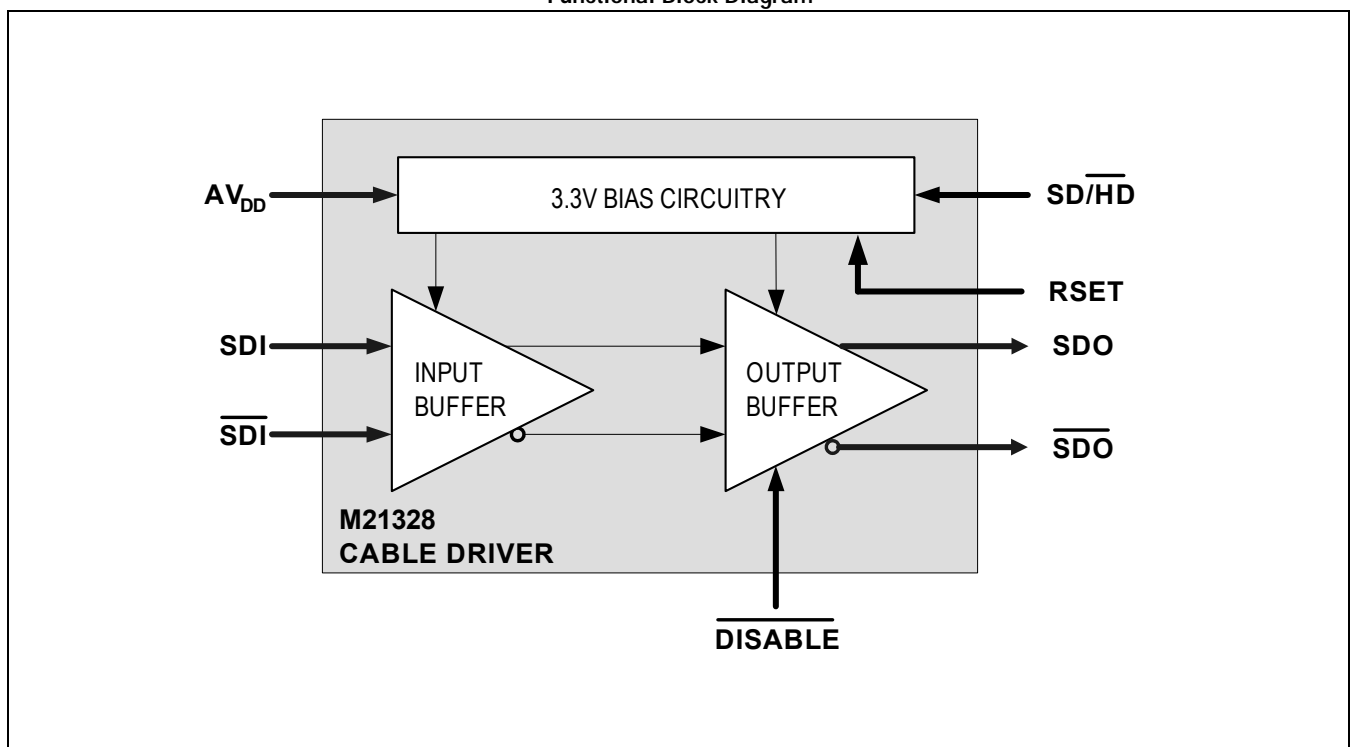

Ordering Information

Part Number	Data Rates Supported	Package	Operating Temperature
M21328G-12*	143–2970 Mbps	4x4 mm MLF—16pins (RoHS compliant)	-10 °C to 85 °C

NOTES:

- * Consult the price list for exact part number when ordering.
- * The letter 'G' designator after the part number indicates a RoHS-compliant package. Refer to www.mindspeed.com for additional information.

Revision History

Revision	Level	Date	Description
A	Advance	May 2007	Initial Release.
B	Release	July 2007	Added θ_{JA} (Junction to ambient Thermal Resistance) to Table 1-2 .
C	Release	December 2007	Output disable pin added. Revised package dimensions. HD/2xHD rise/fall time max changed to 135 ps. Overshoot changed to +/-10%.
D	Release	September 2008	Table 1-3, removed pin 6 from the "Not Connected" list. Table 1-5, removed 1485 Mbps from pin 10 description. Removed section on Moisture Sensitivity Level.
E	Release	November 2009	Updated for -12 part. Added marking diagram.

M21328 Marking Diagram

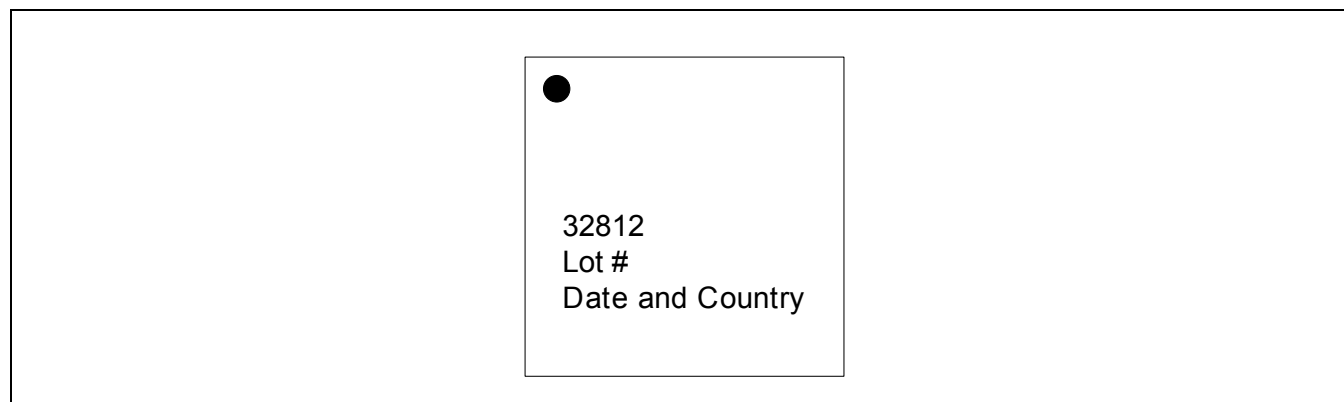



Table of Contents

Ordering Information	2
Revision History	2
Table of Contents	3
List of Figures	4
List of Tables	5
1.0 Product Specification	6
1.1 Absolute Maximum Ratings	6
1.2 Recommended Operating Conditions	6
1.3 DC Electrical Specifications	7
1.4 Input/Output Level Specifications	7
1.5 Package Specification	11
1.5.1 Mechanical Description	11
1.5.1.1 Package Information	11
1.6 Manufactureability	13
1.6.1 Electrostatic Discharge	13
1.6.2 Peak Reflow Temperature	13
1.7 Design Considerations	13
2.0 Functional Description	14
2.1 Features	14
2.1.1 HD-SDI and SD-SDI Slew-rate Selection	14
2.1.2 Output Amplitude Adjustment	14
2.2 Pin Definitions	15
2.2.1 High-speed Inputs	15
2.2.2 High-speed Outputs	16
2.2.3 M21328 Pin List	17
Appendix	18
A.1 Glossary of Terms/Acronyms	18
A.2 Reference Documents	19
A.2.1 External	19



List of Figures

Figure 1-1. Output Symbols Definition	10
Figure 1-2. M21328 Pin Out	11
Figure 1-3. Package Drawing (4x4 mm MLF Package)	12
Figure 2-1. Typical Input Circuit—AC Coupled	15
Figure 2-2. Typical Input Circuit—DC Coupled	15
Figure 2-3. Typical Output Matching/Back-termination Circuit	16



List of Tables

Table 1-1.	Absolute Maximum Ratings	6
Table 1-2.	Recommended Operating Conditions	6
Table 1-3.	Power DC Electrical Specifications	7
Table 1-4.	CMOS Input Electrical Specifications	7
Table 1-5.	High-Speed Input Electrical Specifications	8
Table 1-6.	Cable Driver Output Electrical Specifications (SD/HD/2xHD)	9
Table 2-1.	Output Swing vs. Supply and Termination Voltage	14
Table 2-2.	Interface Pins	17
Table 2-3.	Power Pins	17
Table 2-4.	High-speed Signal Pins	17
Table 2-5.	Control Pins	17



1.0 Product Specification

1.1 Absolute Maximum Ratings

Table 1-1. Absolute Maximum Ratings

Symbol	Parameter	Minimum	Maximum	Units
V_{DD}	Power	$AV_{SS} - 0.5$	$AV_{SS} + 3.47$	V
V_{IOAM}	Any I/O Pin	$AV_{SS} - 0.5$	$AV_{DD} + 0.5$	V
T_{STORE}	Storage Temperature	-65	+150	°C
ESD_{HBML}	Human Body Model (low-speed)	2000	—	V
ESD_{HBMH}	Human Body Model (high-speed outputs)	2000	—	V
ESD_{CDM}	Charge Device Model	500	—	V

NOTE:
1. No Damage.

1.2 Recommended Operating Conditions

Table 1-2. Recommended Operating Conditions

Symbol	Parameter	Notes	Minimum	Typical	Maximum	Units
AV_{DD}	AV_{DD} Power	1	—	3.3	—	V
AV_{SS}	AV_{SS} Ground	—	—	0	—	V
T_A	Ambient Temperature	—	-10	—	+85	°C
θ_{JA}	Junction to ambient Thermal Resistance	—	—	61	—	°C/W
AV_{DD_TERM}	75Ω Output Termination Voltage	See Table 2-1 .				

NOTES:
1. ±5% is allowed from nominal supply.

1.3 DC Electrical Specifications

Table 1-3. Power DC Electrical Specifications

Symbol	Parameter	Notes	Minimum	Typical	Maximum	Units
I_{DD}	Supply Current	1, 2	—	27	36	mA
I_{DDTERM}	Current in external termination resistors	1, 2, 3	—	22	—	mA
$P_{DISSINT1}$	Power dissipation ($AV_{DD} = 3.3V, AV_{DDTERM} = 3.3V$)	1, 2, 5	—	144	—	mW
$P_{DISSINT1}$	Power dissipation ($AV_{DD} = 3.3V, AV_{DDTERM} = 5.0V$)	1, 2, 5	—	181	—	mW
$P_{DISSTOT1}$	Power dissipation ($AV_{DD} = 3.3V, AV_{DDTERM} = 3.3V$)	1, 2, 4	—	162	—	mW
$P_{DISSTOT1}$	Power dissipation ($AV_{DD} = 3.3V, AV_{DDTERM} = 5.0V$)	1, 2, 4	—	199	—	mW

NOTES:

- Recommended operating conditions—see [Table 1-2](#).
- 800 mV standard SMPTE swing, terminated as in [Figure 2-3](#).
- A portion of the power will be dissipated in the external 75Ω termination ($P_{EXT} = V_{OD} \times I_{TERM}$).
- $P_{DISSTOT} = AV_{DD} \times I_{DD} + AV_{DDTERM} \times I_{TERM}$.
- $P_{DISSINT} = P_{DISSTOT} - P_{EXT}$.

1.4 Input/Output Level Specifications

Table 1-4. CMOS Input Electrical Specifications

Symbol	Parameter	Notes	Minimum	Typical	Maximum	Units
V_{IH}	Input Logic High Voltage	1	$0.75 \times AV_{DD}$	—	$AV_{DD} + 0.3$	V
V_{IL}	Input Logic Low Voltage	1	0	—	$0.25 \times AV_{DD}$	V
I_{IH}	Input Current (logic High)	1	-100	—	100	μA
I_{IL}	Input Current (logic Low)	1	-100	—	100	μA

NOTE:

- Specified at recommended operating condition—see [Table 1-2](#).

Table 1-5. High-Speed Input Electrical Specifications

Symbol	Parameter	Notes	Minimum	Typical	Maximum	Units
DR _{IN}	Input Bit Rate	1, 2	0	—	2970	Mbps
V _{ID}	Input Differential Voltage (peak to peak)	1, 3, 4	100	—	2000	mV
V _{CM}	Input Common-Mode Voltage	1	1200	—	AV _{DD}	mV
V _{IH}	Maximum Input High Voltage	1	—	—	AV _{DD} + 400	mV
V _{IL}	Minimum Input Low Voltage	1	1.2	—	—	V
R _{IN}	Single-ended input impedance	1	—	13.33	20	kΩ

NOTES:

1. Specified at recommended operation conditions—see [Table 1-2](#).
2. Part is DC coupled at the input.
3. Example 1200 mV_{pp} differential = 600 mV_{pp} for each single-ended terminal.
4. Minimum input level defined as BER ≤ 10⁻¹².

Table 1-6. Cable Driver Output Electrical Specifications (SD/HD/2xHD)

Symbol	Parameter	Notes	Minimum	Typical	Maximum	Units
DR _{OUT}	Output Bit Rates	1, 5	0	—	2970	Mbps
t _r /t _f	SD Rise/Fall Time (20–80%)	1, 3, 5	400	600	800	ps
	HD/2xHD Rise/Fall Time (20–80%)	1, 3, 5	—	100	135	ps
t _r /t _{rMM}	Rise/fall mismatch (HD/2xHD Rate)	1, 2, 5	—	10	30	ps
	Rise/fall mismatch (SD Rate)	1, 2, 5	—	40	100	ps
V _O	Single-ended voltage swing range p–p	1, 2, 4, 5	500	800	1600	mV
V _{OTOL}	Swing Level output variation at 800 mVpp [RSET = 750ohm ±1%] (Single-Ended)	1, 2, 3, 5	-7	—	+7	%
V _{OS}	Overshoot/Undershoot	1, 2, 5	-10	—	+10	%
JAO _{pp}	Additive Output Jitter (HD/2xHD rate)	1, 5, 8	—	20	30	ps
	Additive Output Jitter (SD rate)	1, 5, 8	—	40	60	ps
DCD _O	Duty Cycle Distortion (HD/2xHD Rate)	1, 2, 5, 6, 8	—	15	30	ps
	Duty Cycle Distortion (SD Rate)	1, 2, 5, 6, 8	—	20	70	ps
S ₂₂	Output Return Loss (5 MHz to 1.5 GHz)	1, 2, 5, 7	15	—	—	dB
S ₂₂	Output Return Loss (5 MHz to 3.0 GHz)	1, 2, 5, 7	10	—	—	dB

NOTES:

- Entire table specified at recommended operating condition with 400 mV_{p-p} differential input—see [Table 1-2](#).
- Specification verified at 800 mVpp output with 1m cable on MSPD test board. System results may vary.
- Rated at nominal SMPTE 800 mV output swing level (using a 750Ω ±1% resistor at RSET).
- Output stage is an open collector differential pair, actual swing dependant on IC supply voltage and external termination voltage.
- Into 75Ω back termination and 75Ω load and appropriate external termination voltage, see [Table 2-1](#), [Figure 2-3](#).
- Duty Cycle Distortion (DCD) is defined as the difference in the intrinsic jitter at the 50% voltage level and the intrinsic jitter at the rising/falling edge crossing point. If the rising/falling edge crossing point is at the 50% voltage level, then DCD = 0.
- Measured under DC conditions that simulate AC coupling, V_T = 3.3V.
- Measured using a “1010” data pattern.

Figure 1-1. Output Symbols Definition

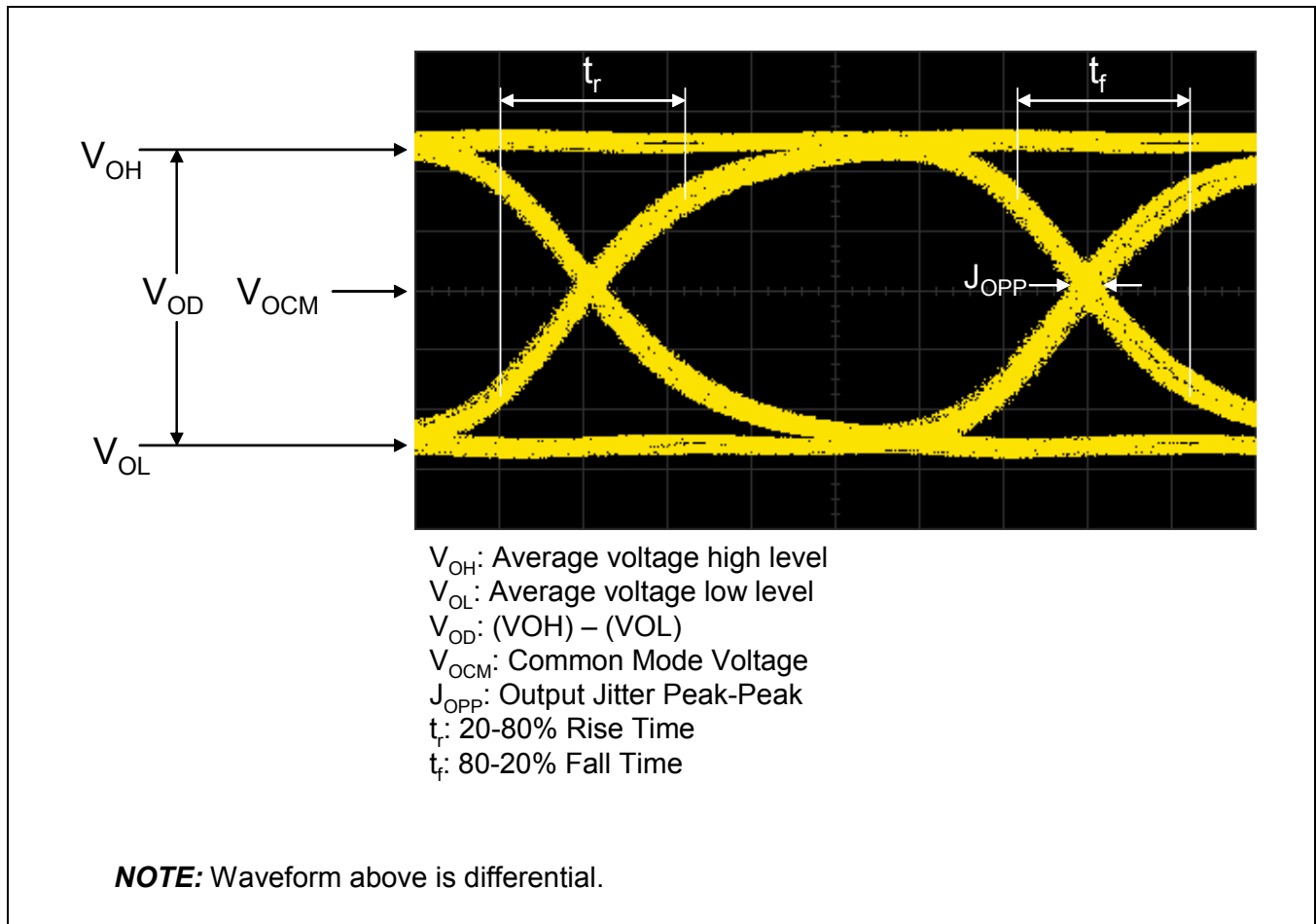

1.5 Package Specification

1.5.1 Mechanical Description

1.5.1.1 Package Information

The M21328 is available in a 16 pin 4x4mm MLF IC package. The pin out is shown in [Figure 1-2](#) and the package drawing in [Figure 1-3](#).

Figure 1-2. M21328 Pin Out

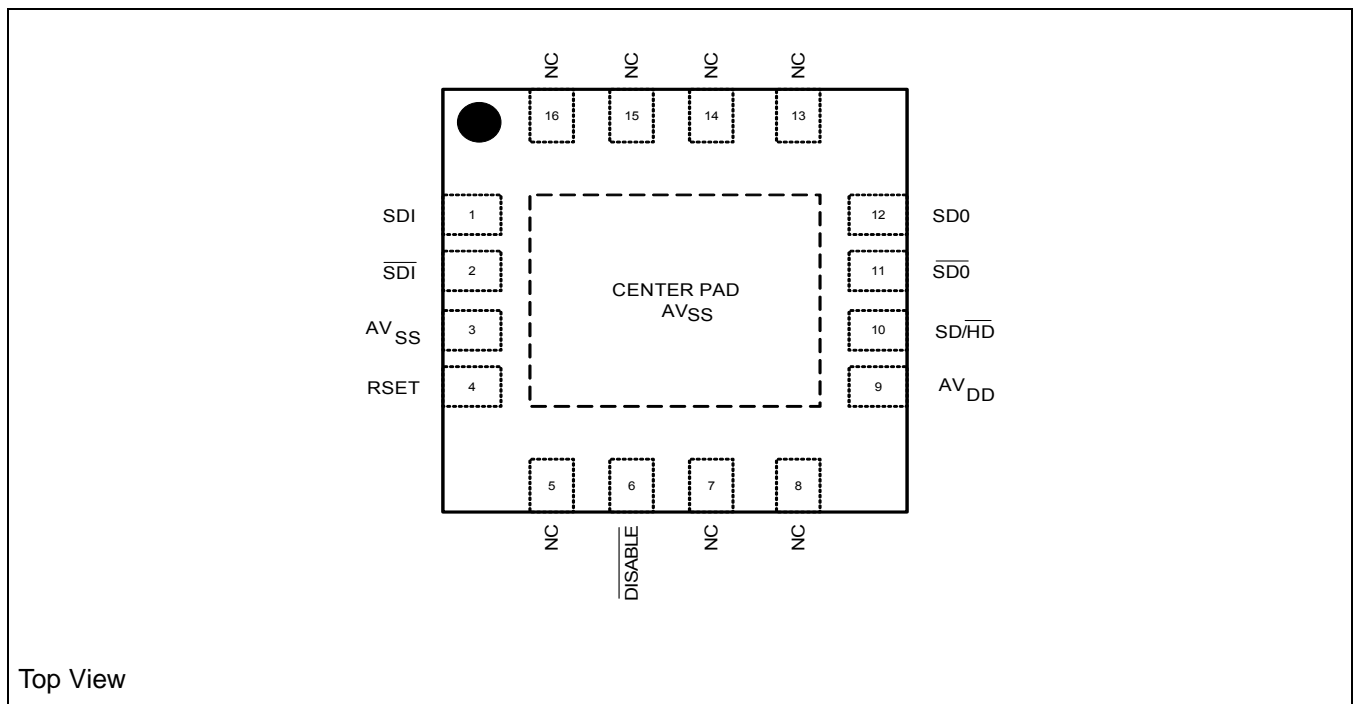
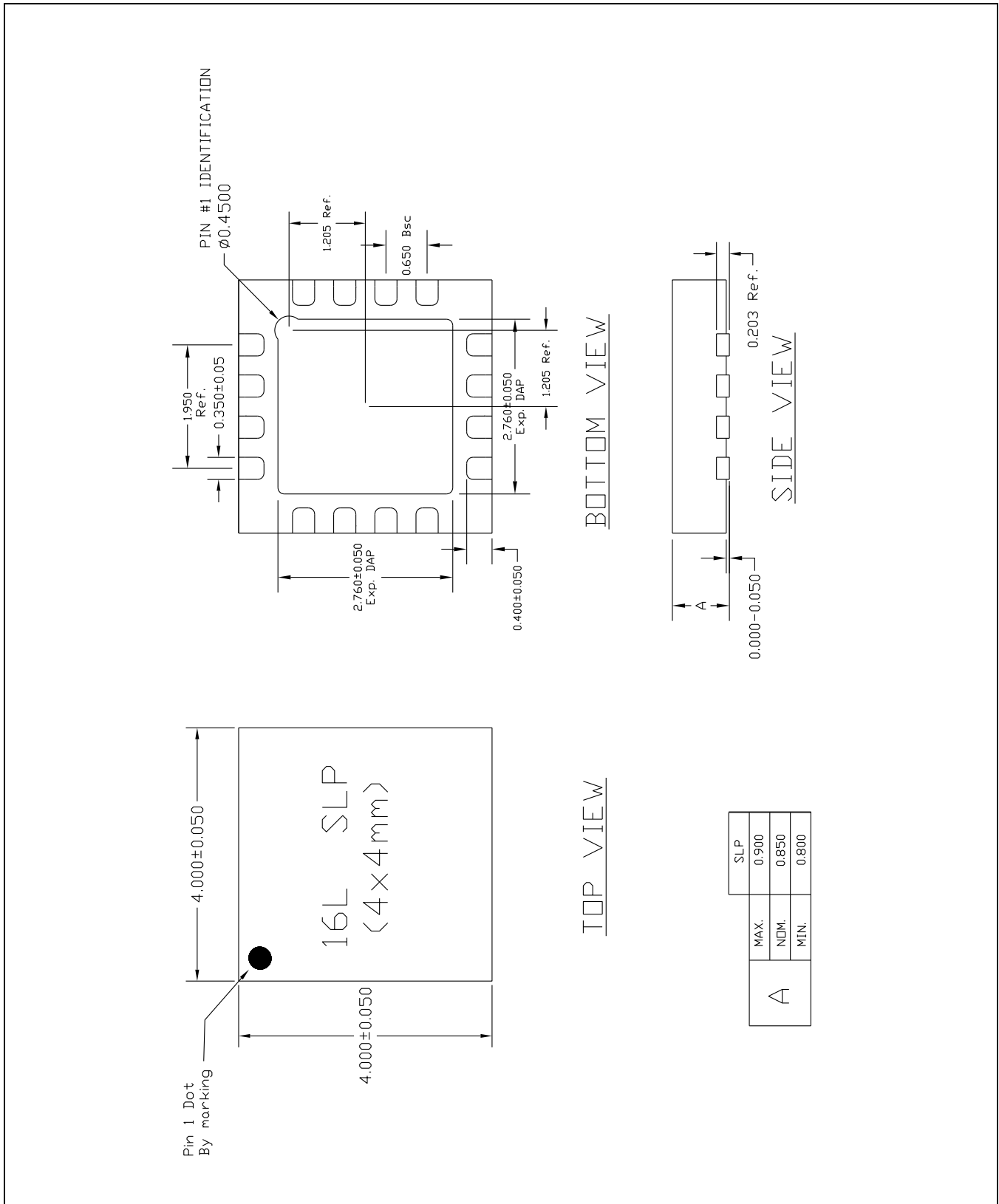

Figure 1-3. Package Drawing (4x4 mm MLF Package)



1.6 Manufactureability

The values shown in this section may change; however, these are standard requirements.

1.6.1 Electrostatic Discharge

Tested per JESD22-A114. This device passes 2000V of ESD Human Body Model (HBM) testing.

Tested per JESD22-C101. This device passes 500V of ESD Charged Device Model (CDM) testing.

Tested per EIA/JESD78. This device passes 150mA of trigger current at 85°C during Latchup testing.

1.6.2 Peak Reflow Temperature

M21328G (RoHS compliant package): Peak reflow temperature is 260°C per JEDEC standards.

1.7 Design Considerations

See Digital Video Interfacing Application Note (212xx-APP-001-A) for guidance on the following:

- Component Placement and Layout
- Routing Considerations and Thermal Considerations

The M21328 consumes less power than legacy devices, therefore the M21328 will contribute less thermal energy resulting in a lower operating temperature.



2.0 Functional Description

2.1 Features

2.1.1 HD-SDI and SD-SDI Slew-rate Selection

The output slew rate of the M21328 is selectable to conform with the different SD-SDI, HD-SDI, and 2xHD specifications. With $\overline{\text{SD/HD}}$ = Low, rise/fall time is typically 100 ps. The slew rate will vary depending on the output matching network and connector used.

With $\overline{\text{SD/HD}}$ = High, for standard definition (143 to 540 Mbps) applications, the rise/fall time is typically 600 ps, which is compliant with SMPE 259M and SMPTE 344M.

2.1.2 Output Amplitude Adjustment

A resistor connected to **RSET** pin is used to set the single ended output amplitude swing.

For SMPTE compliance, an external $750\Omega \pm 1\%$ resistor at **RSET** to **A_{VDD}** is recommended for a swing level of 800mV within a tolerance that is less than $\pm 10\%$ which meets SMPTE requirements. The output amplitude can also be adjusted to range from 500 to 1600 mVpp single ended using the following formula:

$$\text{Output Swing} = (600/\text{RSET}) [\text{RSET in k}\Omega] \text{ (in mVpp, Single Ended)}$$

The actual swing is set as a function of the IC supply voltage, the external termination voltage and the limitations are shown in [Table 2-1](#). In applications where a lossy matching or splitting networks are used, the M21328 offers additional gain of up to 1600 mVpp swings, so the output after the lossy network can be SMPTE compliant.

Table 2-1. Output Swing vs. Supply and Termination Voltage

A_{VDD} (V)	$A_{VDDTERM}$ (V)	Maximum Swing (Single-ended mVp-p)	Minimum Swing (Single-ended mVp-p)
3.3V	3.3V	1200 mV	500 mV
3.3V	5.0V	1600 mV	500 mV

2.2 Pin Definitions

2.2.1 High-speed Inputs

The M21328 is designed to be operated with input signals as low as 100 mV or up to 2000 mV differential peak to peak. The M21328 uses external 50Ω input termination resistors to match 100Ω differential impedance transmission lines for improved system level performance. The M21328 recommended input circuits are shown in [Figure 2-1](#) and [Figure 2-2](#).

Note that AC coupling is not required when the M21328 is driven by Mindspeed Broadcast video devices.

Figure 2-1. Typical Input Circuit—AC Coupled

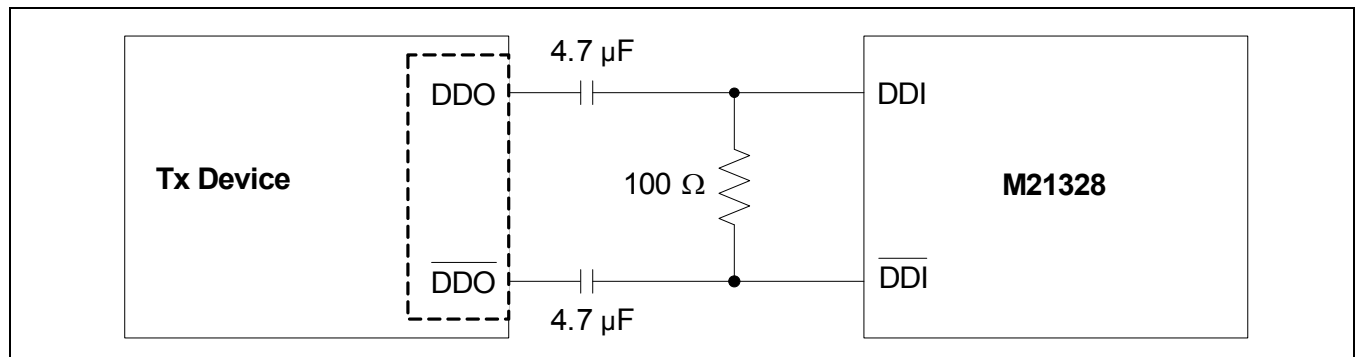
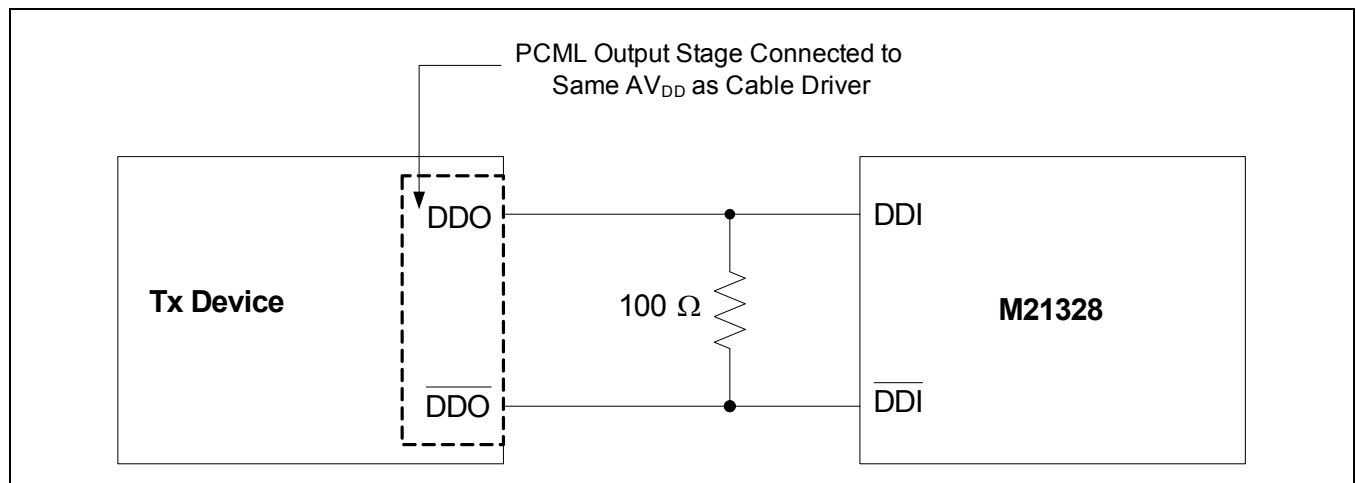

Figure 2-2. Typical Input Circuit—DC Coupled



2.2.2 High-speed Outputs

The M21328 output buffer is an open collector buffer that is designed for a return loss of 15 dB at SD and HD rates and 10 dB at 2xHD rates, using standard through-hole BNC connectors as typically employed in broadcast video equipment. A typical output matching circuit is shown in [Figure 2-3](#). The Output Return Loss (ORL) is dependent on many factors such as the value and type of components used, PCB layout, PCB trace lengths, and type of PCB di-electric, therefore, the recommendations in the figure below should be used as starting guidelines only. Different output matching network topologies and different component values will result in different ORL performance.

The M21328 has SD-SDI and HD-SDI rise/fall times that are typically faster than the legacy cable driver devices but within the relevant SMPTE specification for additional margin in most designs. The faster output slew rate results in a more open eye. The actual maximum output of the part depends on the applied IC voltage as well as the external termination voltage for the load termination. The limitations are discussed in [Section 2.1](#).

Figure 2-3. Typical Output Matching/Back-termination Circuit

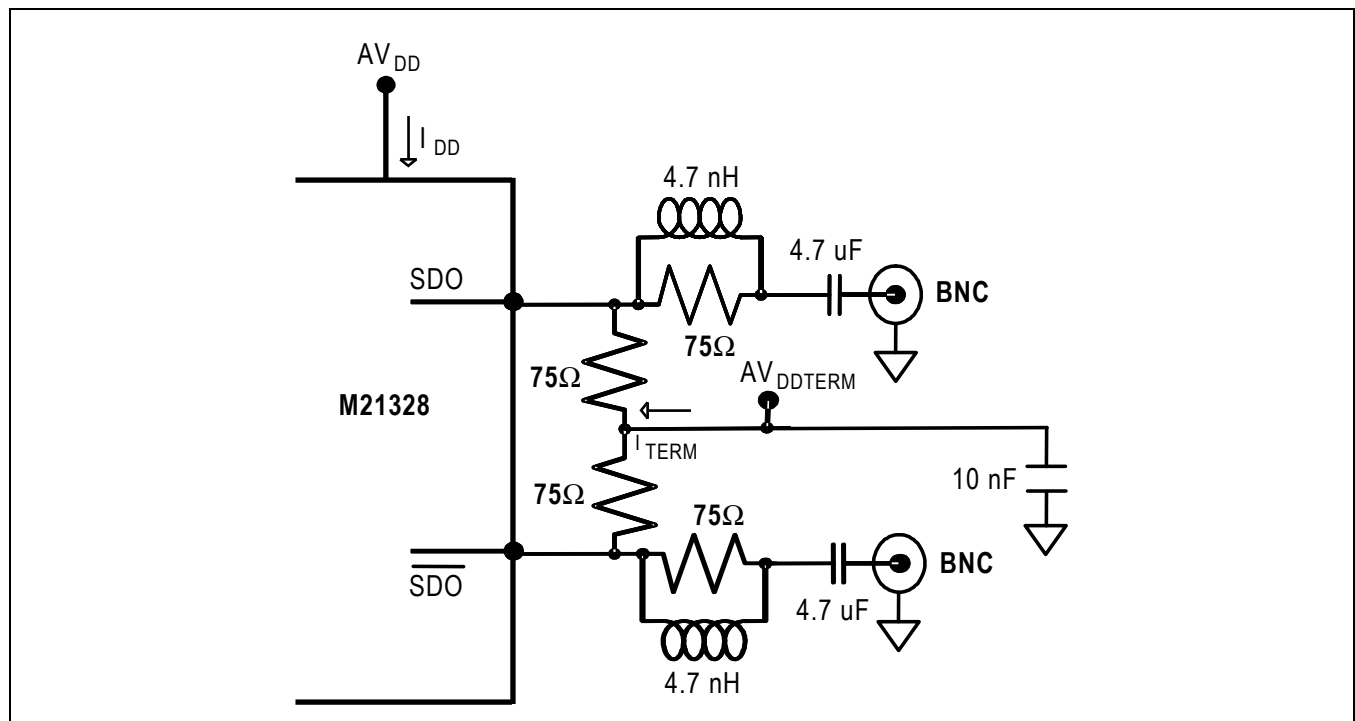

2.2.3 M21328 Pin List

Table 2-2. Interface Pins

Pin Name	Pin #	Function	Default	Type
RSET	4	Input control signal for setting the single-ended output swing amplitude. Higher output swing levels or reduced variations with a $\pm 1\%$ tolerance external resistor. For 800mVp-p single-ended, a $750\Omega \pm 1\%$ resistor to AV_{DD} is recommended.	—	Analog Input

Table 2-3. Power Pins

Pin Name	Pin #	Function	Type
AV_{SS}	3	Chip Ground	Power
AV_{DD}	9	Positive Supply	Power
NC	5, 7, 8, 13, 14, 15, 16	Not Connected. Leave these pins floating. Do not connect to any supply, ground or logic level.	NC
Center Pad	—	Chip Ground	Power

Table 2-4. High-speed Signal Pins

Pin Name	Pin #	Function	Default	Type
SDI/\overline{SDI}	1, 2	Non-inverting and Inverting serial externally terminated inputs.	—	I—High-speed
SDO/\overline{SDO}	12, 11	Non-inverting and inverting serial unterminated data outputs to coaxial cable.	—	O—High-speed

Table 2-5. Control Pins

Pin Name	Pin #	Function	Default	Type
SD/\overline{HD}	10	Input control signal to change the output slew rate. SD/\overline{HD} = High: Slow output slew rate for SD-SDI rate (143–540 Mbps). SD/\overline{HD} = Low: Fast output slew rate for HD and 2xHD-SDI rate.	Pull-up	I—CMOS
$\overline{DISABLE}$	6	A low disables the SDO/\overline{SDO} outputs. A high enables the SDO/\overline{SDO} outputs.	Pull-up	I—CMOS

NOTES:

Internal pull-ups/pull-downs are 100 k Ω .



Appendix

A.1 Glossary of Terms/Acronyms

BER	Bit Error Rate
CD	Cable Driver
CDA	Cable Distribution Amplifier
CML	Current Mode Logic
CMOS	Complementary Metal Oxide Semiconductor
DPLL	Digital Phase Locked Loop
DTV	Digital Television
DVB	Digital Video Broadcast
EMI	Electro Magnetic Interference
EQ	Equalizer or Equalization
GREEN	Environmentally friendly
HD	High Definition
HW	Hardware
IC	Integrated Circuit
ID	Identifier
I/O	Input/Output
MLF	Micro Lead Frame package (also called QFN)
PCB	Printed Circuit Board
ORL	Output Return Loss
RoHS	Restriction of Hazardous Substances
SD	Standard Definition
SDI	Serial Digital Input
SDO	Serial Digital Output
SE	Single Ended
SMPTE	Society of Motion Picture and Television Engineers

A.2 Reference Documents

A.2.1 External

The following external documents were referenced in this data sheet.

- Application Notes for Surface Mount Assembly of Amkor's MicroLeadFrame (MLF) Packages
- Amkor Technology Thermal Test Report TT-00-06 (See <http://www.amkor.com> for detailed information)
- SMPTE 292M, SMPTE 259M, SMPTE 344M
- ESI TR101 891 DVB Asynchronous Serial Interface (ASI)

www.mindspeed.com

General Information:
Telephone: (949) 579-3000
Headquarters - Newport Beach
4000 MacArthur Blvd., East Tower
Newport Beach, CA 92660

© 2007-2009 Mindspeed Technologies®, Inc. All rights reserved.

Information in this document is provided in connection with Mindspeed Technologies® ("Mindspeed®") products. These materials are provided by Mindspeed as a service to its customers and may be used for informational purposes only. Except as provided in Mindspeed's Terms and Conditions of Sale for such products or in any separate agreement related to this document, Mindspeed assumes no liability whatsoever. Mindspeed assumes no responsibility for errors or omissions in these materials. Mindspeed may make changes to specifications and product descriptions at any time, without notice. Mindspeed makes no commitment to update the information and shall have no responsibility whatsoever for conflicts or incompatibilities arising from future changes to its specifications and product descriptions. No license, express or implied, by estoppel or otherwise, to any intellectual property rights is granted by this document.

THESE MATERIALS ARE PROVIDED "AS IS" WITHOUT WARRANTY OF ANY KIND, EITHER EXPRESS OR IMPLIED, RELATING TO SALE AND/OR USE OF MINDSPEED PRODUCTS INCLUDING LIABILITY OR WARRANTIES RELATING TO FITNESS FOR A PARTICULAR PURPOSE, CONSEQUENTIAL OR INCIDENTAL DAMAGES, MERCHANTABILITY, OR INFRINGEMENT OF ANY PATENT, COPYRIGHT OR OTHER INTELLECTUAL PROPERTY RIGHT. MINDSPEED FURTHER DOES NOT WARRANT THE ACCURACY OR COMPLETENESS OF THE INFORMATION, TEXT, GRAPHICS OR OTHER ITEMS CONTAINED WITHIN THESE MATERIALS. MINDSPEED SHALL NOT BE LIABLE FOR ANY SPECIAL, INDIRECT, INCIDENTAL, OR CONSEQUENTIAL DAMAGES, INCLUDING WITHOUT LIMITATION, LOST REVENUES OR LOST PROFITS, WHICH MAY RESULT FROM THE USE OF THESE MATERIALS.

Mindspeed products are not intended for use in medical, lifesaving or life sustaining applications. Mindspeed customers using or selling Mindspeed products for use in such applications do so at their own risk and agree to fully indemnify Mindspeed for any damages resulting from such improper use or sale.

Данный компонент на территории Российской Федерации

Вы можете приобрести в компании MosChip.

Для оперативного оформления запроса Вам необходимо перейти по данной ссылке:

<http://moschip.ru/get-element>

Вы можете разместить у нас заказ для любого Вашего проекта, будь то серийное производство или разработка единичного прибора.

В нашем ассортименте представлены ведущие мировые производители активных и пассивных электронных компонентов.

Нашей специализацией является поставка электронной компонентной базы двойного назначения, продукции таких производителей как XILINX, Intel (ex.ALTERA), Vicor, Microchip, Texas Instruments, Analog Devices, Mini-Circuits, Amphenol, Glenair.

Сотрудничество с глобальными дистрибьюторами электронных компонентов, предоставляет возможность заказывать и получать с международных складов практически любой перечень компонентов в оптимальные для Вас сроки.

На всех этапах разработки и производства наши партнеры могут получить квалифицированную поддержку опытных инженеров.

Система менеджмента качества компании отвечает требованиям в соответствии с ГОСТ Р ИСО 9001, ГОСТ РВ 0015-002 и ЭС РД 009

Офис по работе с юридическими лицами:

105318, г.Москва, ул.Щербаковская д.3, офис 1107, 1118, ДЦ «Щербаковский»

Телефон: +7 495 668-12-70 (многоканальный)

Факс: +7 495 668-12-70 (доб.304)

E-mail: info@moschip.ru

Skype отдела продаж:

moschip.ru

moschip.ru_4

moschip.ru_6

moschip.ru_9