

Features

- **Industry Standard Embedded MultiMediaCard (eMMC) Host Interface**
 - JEDEC/MMC Standard Version 5.1 JESD84-B51 compliant
 - Backward compatible with previous eMMC standards
- **Performance**
 - eMMC clock speed: Up to 200MHz
 - eMMC data bus width: x1/x4/x8
 - Supports Dual Data Rate mode
 - Supports HS200 / HS400 modes
 - Sequential data read: Up to 160 MByte/sec*
 - Sequential data write: Up to 57 MByte/sec*

* measured in HS400 enhanced mode using 1 MByte transfer size
- **Power Management**
 - 3.3V power supply (V_{CC})
 - 3.3V or 1.8V eMMC IO voltage (V_{CCQ})
 - Immediate disabling of unused circuitry without host intervention
- **Power Specifications**
 - Active mode: 471 mW (typical)
 - Sleep mode: 2.15mW (typical)
- **Integrated Voltage Detector**
 - Detects supply voltage fluctuations and generates reset during power-up and power-down to prevent inadvertent writes
- **Expanded Data Protection**
 - Hardware Write Protection pin
- **Latency Management**
 - Reduces latency due to background tasks during time critical read/write operations
- **Robust Built-in ECC**
- **NAND Configuration**
 - 1 bit per cell (SLC)
 - Designed with Greenliant's advanced EnduroSLC™ Technology
- **High Endurance**
 - GLS85VM1004G: 50K P/E cycles (typical)
 - GLS85VM1004Q: 100K P/E cycles (typical)
- **Operating Temperature Range**
 - Industrial: -40°C to 85°C
- **100-ball LPGA Package**
 - 14.0 mm x 18.0 mm x 1.40 mm, 1.0 mm ball pitch, LFWE
- **All Devices are RoHS Compliant**

Product Description

The GLS85VM1004G / 1004Q eMMC NANDrive™ EX Series devices (referred to as “eMMC NANDrive” in this factsheet) are fully integrated solid state drives. They combine an advanced Greenliant NAND controller and 4 GBytes of NAND flash memory in a multi-chip package. These products are ideal for solid state mass storage in embedded and portable applications that require small form-factor and reliable data storage.

eMMC solid state drives are widely used in GPS and telematics, in-vehicle infotainment, portable and industrial computers, handheld data collection scanners, point-of-sale terminals, networking and telecommunications equipment, robotics, audio and video recorders, monitoring devices and set-top boxes.

eMMC NANDrive provides complete eMMC solid state drive (SSD) functionality and compatibility in a 14mm x 18mm BGA package for easy, space saving mounting to a system motherboard. With its small size, low power consumption, strong security, reliability and ruggedness, eMMC NANDrive surpasses removable storage and discrete NAND-based products.

The integrated NAND flash controller with built-in advanced NAND management firmware communicates with the host through the standard eMMC protocol. It does not require any additional or proprietary software such as the Flash File System (FFS) and Memory Technology Driver (MTD).

eMMC NANDrive's advanced NAND management technology enhances data security, improves endurance and accurately tracks the usage of the NAND flash. This innovative technology combines robust error correction capabilities with advanced wear-leveling algorithms and bad block management to extend the life of the product.

eMMC NANDrive supports Single Data Rate (SDR) and Dual Data Rate (DDR) modes, HS200 mode, HS400 mode, boot, multiple partitions, permanent and partial write protect, Replay Protected Memory Block (RPMB) access, Sanitize and TRIM, hardware reset and other features detailed in the eMMC 5.1 standard specification. It is backward compatible with previous eMMC standards.

1.0 GENERAL DESCRIPTION

Each eMMC NANDrive contains an integrated eMMC NAND flash memory controller and NAND flash die in a BGA package. Refer to Figure 2-1 for the eMMC NANDrive block diagram.

1.1 Optimized eMMC NANDrive

The heart of the eMMC NANDrive is the eMMC NAND flash memory controller, which translates standard eMMC signals into flash media data and control signals. The following components contribute to the eMMC NANDrive's operation.

1.1.1 Microcontroller Unit (MCU)

The MCU transfers the eMMC commands into data and control signals required for flash media operation.

1.1.2 Internal Direct Memory Access (DMA)

The eMMC NANDrive uses internal DMA allowing instant data transfer from/to buffer to/from flash media. This implementation eliminates microcontroller overhead associated with the traditional, firmware-based approach, thereby increasing the data transfer rate.

1.1.3 Power Management Unit (PMU)

The PMU controls the power consumption of the eMMC NANDrive. The PMU dramatically reduces the power consumption of the eMMC NANDrive by putting the part of the circuitry that is not in operation into Sleep mode.

The Flash File System handles inadvertent power interrupts and has auto-recovery capability to ensure the eMMC NANDrive's data integrity.

1.1.4 Embedded Flash File System

The embedded flash file system is an integral part of the eMMC NANDrive. It contains MCU firmware that performs the following tasks:

1. Translates host side signals into flash media writes and reads
2. Provides flash media wear leveling to spread flash writes across all memory address space to increase the longevity of flash media
3. Keeps track of the data file structure
4. Manages system security for the selected protection zones

1.1.5 Error Correction Code (ECC)

High performance is achieved through optimized hardware error detection and correction.

1.1.6 Serial Communication Interface (SCI)

The Serial Communication Interface (SCI) is designed for error reporting. During the product development stage, it is recommended to provide the SCI port on the PCB to aid in design validation.

1.1.7 Multi-tasking Interface

The multi-tasking interface enables fast, sequential write performance by allowing concurrent Read, Program and Erase operations to multiple flash media.

1.2 SMT Reflow Consideration

Preprogrammed NAND devices have temperature limits due to data retention. The EnduroSLC™ eMMC NANDrive family uses high-grade SLC NAND flash, which can retain data in high temperature environments. Using Greenliant's recommended reflow profile during production will help prevent damage to the device and ensure better retention of any preprogrammed data through the surface-mount soldering process. See the relevant datasheet section describing the recommended reflow temperature limits.

1.3 Advanced NAND Management

eMMC NANDrive's integrated controller uses advanced wear-leveling algorithms to substantially increase the longevity of NAND flash media. Wear caused by data writes is evenly distributed in all or select blocks in the device that prevents "hot spots" in locations that are programmed and erased extensively. This effective wear-leveling technique results in optimized device endurance, enhanced data retention and higher reliability required by long-life applications.

2.0 FUNCTIONAL BLOCKS

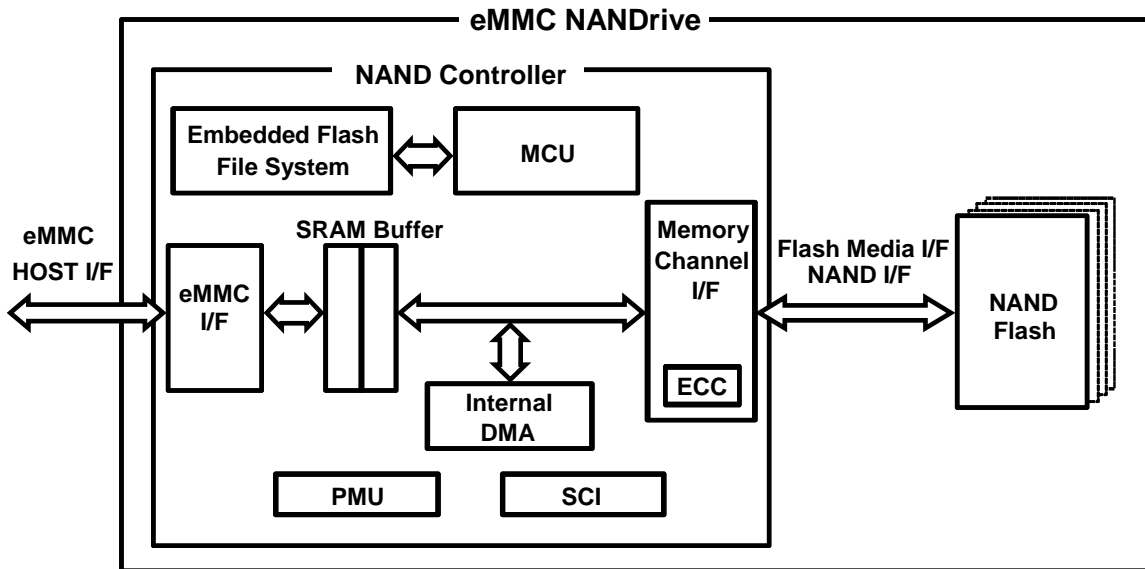
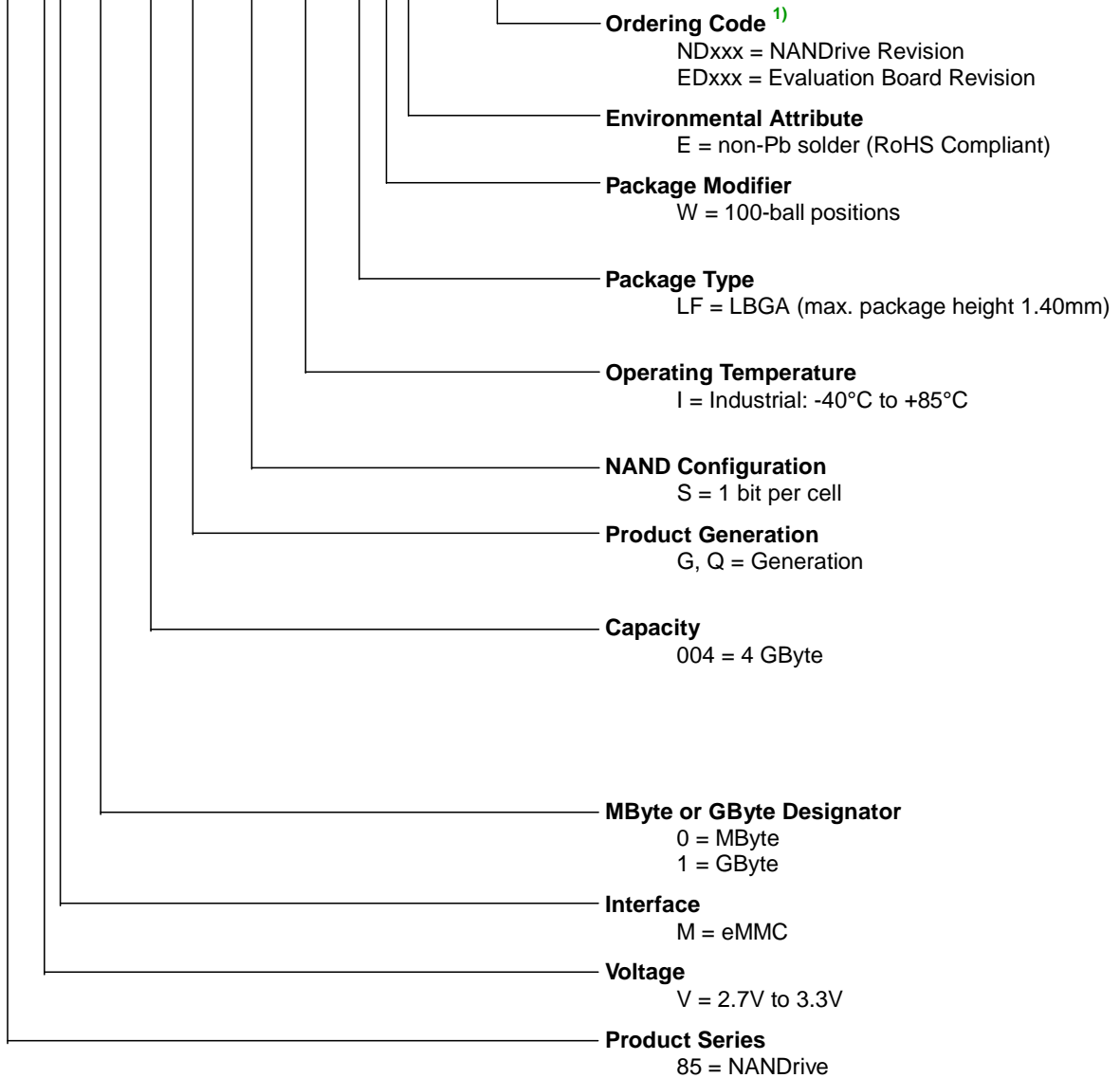

Figure 2-1: eMMC NANDrive Block Diagram

3.0 Product Ordering Information

GLS 85 VM 1 0xx x - S - I - LFWE - NDxxx
 XX XX X XXXX - X - X - XXXX - XXXXX



1) Note that the top side marking on the package typically does not include ordering codes (e.g. NDxxx), unless it is a special custom specification (C-SPEC) required by the end-customer to be marked on the device.

Valid Combinations

Valid product combinations are those that are in mass production or will be in the mass production. Consult your Greenliant sales representative to confirm availability of the valid combinations and to determine availability of new product combinations.

Table 3-1: eMMC NANDrive Product Valid Ordering Numbers

Capacity	Operating Temperature	Part Number	Package
4GB	Industrial (-40°C to 85°C)	GLS85VM1004G-S-I-LFWE-ND217	LFWE, 14x18x1.40mm
4GB	Industrial (-40°C to 85°C)	GLS85VM1004Q-S-I-LFWE-ND218	LFWE, 14x18x1.40mm

Table 3-2: eMMC Evaluation Board Valid Ordering Numbers

Capacity	Operating Temperature	Part Number	Form Factor ²⁾
4GB	Industrial (-40°C to 85°C)	GLS85VM1004G-S-I-E2-ED217	JEDEC MO-277
4GB	Industrial (-40°C to 85°C)	GLS85VM1004Q-S-I-E2-ED218	JEDEC MO-277

- 2) The evaluation boards with the form factor MO-277 support up to 52MHz with x1/x4/x8 bus and Dual Data Rate mode. Use them for comprehensive functional testing. If the end-user's system has support for 200MHz bus speed, it can be tested only with eMMC 5.1 NANDrive devices soldered down on the user's board.

4.0 Package Diagram

GLS85VM1004G / 1004Q-S-I-LFWE

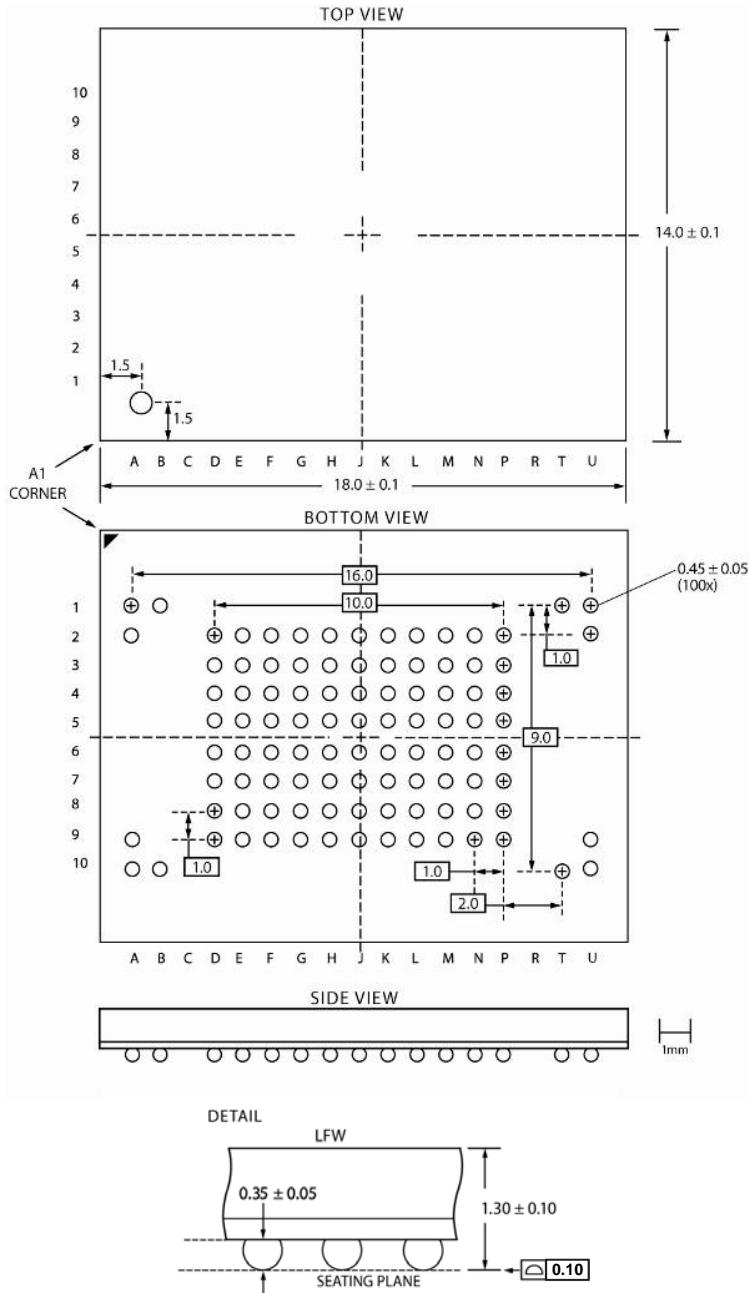

Note: All linear dimensions are in millimeters.
 Untoleranced dimensions are nominal target values.
 Coplanarity: 0.10 mm
 Ball diameter is 0.45 mm (± 0.05 mm)
 Ball opening size is 0.38 mm (± 0.05 mm), SMD type

Figure 4-1: eMMC NANDrive 100-Ball, Ball Grid Array (BGA) Greenliant Package Code: LFWE

Revision History

Number	Description	Date
01.000	Initial release as Factsheet	January 28, 2019
01.001	Added Endurance on page 1	April 30, 2019

© 2019 Greenliant. All rights reserved.

Greenliant and the Greenliant logo are registered trademarks, and EnduroSLC and NANDrive are trademarks of Greenliant. All other trademarks and registered trademarks are the property of their respective owners.

Specifications are subject to change without notice. Memory sizes denote raw storage capacity; actual usable capacity may be less.

Greenliant makes no warranty for the use of its products other than those expressly contained in the Greenliant Terms and Conditions of Sale.

www.greenliant.com

Данный компонент на территории Российской Федерации

Вы можете приобрести в компании MosChip.

Для оперативного оформления запроса Вам необходимо перейти по данной ссылке:

<http://moschip.ru/get-element>

Вы можете разместить у нас заказ для любого Вашего проекта, будь то серийное производство или разработка единичного прибора.

В нашем ассортименте представлены ведущие мировые производители активных и пассивных электронных компонентов.

Нашей специализацией является поставка электронной компонентной базы двойного назначения, продукции таких производителей как XILINX, Intel (ex.ALTERA), Vicor, Microchip, Texas Instruments, Analog Devices, Mini-Circuits, Amphenol, Glenair.

Сотрудничество с глобальными дистрибьюторами электронных компонентов, предоставляет возможность заказывать и получать с международных складов практически любой перечень компонентов в оптимальные для Вас сроки.

На всех этапах разработки и производства наши партнеры могут получить квалифицированную поддержку опытных инженеров.

Система менеджмента качества компании отвечает требованиям в соответствии с ГОСТ Р ИСО 9001, ГОСТ РВ 0015-002 и ЭС РД 009

Офис по работе с юридическими лицами:

105318, г.Москва, ул.Щербаковская д.3, офис 1107, 1118, ДЦ «Щербаковский»

Телефон: +7 495 668-12-70 (многоканальный)

Факс: +7 495 668-12-70 (доб.304)

E-mail: info@moschip.ru

Skype отдела продаж:

moschip.ru

moschip.ru_4

moschip.ru_6

moschip.ru_9