

# DC Current Transducer

## DIN RAIL / PANEL MOUNT, RMS



Single Element - .79" Window  
2 to 300 ADC Input Range



Single Element - 1.2" Window  
20 to 300 ADC Input Range

The **CR5200** Series, DC Current Transducers are designed to provide a DC signal which is proportional to a DC sensed current. These devices are designed for direct current only, targeting them towards general and daily applications. The ranges 2 to 10 Amp utilize an advanced Magnetic Modulator technology and the ranges 20 amps and above utilize Hall Effect technology.

### Applications

Battery chargers and systems  
DC motor drives  
Power supply management  
Mobile applications

### Features

Closed loop sensing for accuracy  
35mm DIN rail or panel mount  
Available with  $\pm 5$  VDC,  $\pm 10$  VDC or 4 - 20 mADC outputs  
Non-contact DC current sensing  
Connection diagram printed on case

### Regulatory Agencies



All single element current transducers are available in split core design.  
Simply put an "S" at the end of the prefix

PART NUMBERS			
<b>CR5210(S)</b>	-		Single Element with $\pm 5$ VDC output (split core design)
<b>CR5211(S)</b>	-		Single Element with $\pm 10$ VDC output (split core design)
<b>CR5220(S)</b>	-		Single Element with 4 - 20 mADC output (split core design)
NOTE: DC Split Core Transducers Available in 20 Amps and Higher			
NOTE: CR5200 Series is available with 12V Power Supply. Use same application as 24V Power Supply.			
Example Part Number: CR5210-300-12.			

Add suffix for input range

<b>2</b>	-	0-2 ADC
<b>5</b>	-	0-5 ADC
<b>10</b>	-	0-10 ADC
<b>20</b>	-	0-20 ADC
<b>30</b>	-	0-30 ADC
<b>50</b>	-	0-50 ADC
<b>75</b>	-	0-75 ADC
<b>100</b>	-	0-100 ADC
<b>150</b>	-	0-150 ADC
<b>300</b>	-	0-300 ADC

Ranges available up to and including 600 ADC



Another HUNTINGTON ELECTRIC Company

CR Magnetics, Inc. 3500 Scarlet Oak Blvd. St. Louis MO USA 63122 V: 636-343-8518 F: 636-343-5119

Web: <http://www.crmagnetics.com>

E-mail: [sales@crmagnetics.com](mailto:sales@crmagnetics.com)

Transducers

### SPECIFICATIONS

Basic Accuracy:.....	1.0 %	Output Load:.....	$\pm 5$ or $\pm 10$ VDC.....	2 K $\Omega$ or greater
Thermal Drift:.....	500 PPM/ $^{\circ}$ C		4-20 mADC.....	0 - 300 $\Omega$
Operating Temperature:.....	0 $^{\circ}$ C to +50 $^{\circ}$ C	Supply Current:		
Response Time: .....	250 ms. max.,0-90% FS	CR5210:.....	Typical 35mA	Max 40mA
Insulation Voltage:.....	2500 VDC	CR5210S:.....	Typical 30mA	Max 35mA
Supply Voltage:.....	24 VDC $\pm 10\%$	CR5220:.....	Typical 60mA	Max 100mA
Frequency Range:.....	DC only	CR5220S:.....	Typical 40mA	Max 50mA
MTBF:.....	Greater than 100 K hours	Torque Specs:.....	3.0 inch lbs. (0.4Nm)	
		Weight:.....	0.5 lbs.	

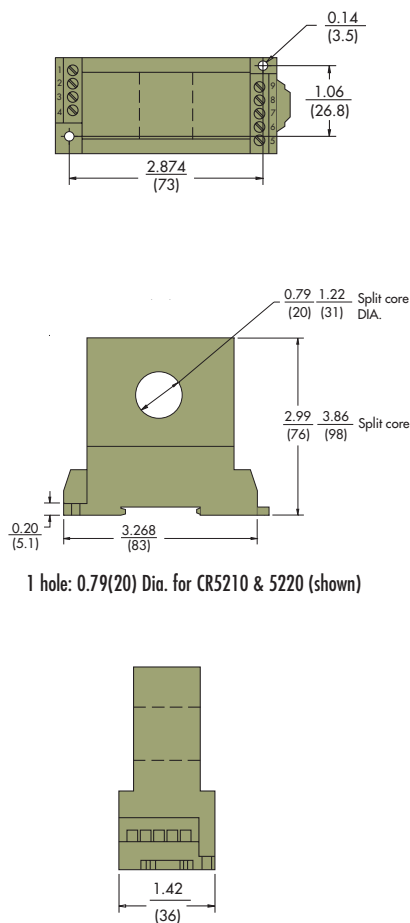

### OUTLINE DRAWING

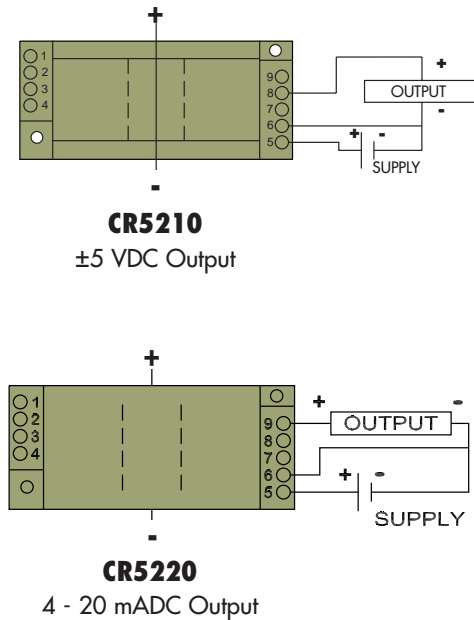

### CONNECTION DIAGRAM

NOTE: The building installation must have a switch or circuit-breaker that is in close proximity and within easy reach of the operator. The switch or circuit breaker shall be marked as the disconnecting device for the equipment.

C  
Transducers



## Данный компонент на территории Российской Федерации

### Вы можете приобрести в компании MosChip.

Для оперативного оформления запроса Вам необходимо перейти по данной ссылке:

<http://moschip.ru/get-element>

Вы можете разместить у нас заказ для любого Вашего проекта, будь то серийное производство или разработка единичного прибора.

В нашем ассортименте представлены ведущие мировые производители активных и пассивных электронных компонентов.

Распределительные склады, находящиеся в России, Европе и в Китае, позволяют нам оперативно поставить необходимые компоненты в оптимальные для Вас сроки.

На всех этапах разработки и производства наши партнеры могут получить квалифицированную поддержку опытных инженеров.

Система менеджмента качества компании отвечает требованиям ISO 9001:2011

### Офис по работе с юридическими лицами:

107023, г.Москва, Семеновский переулок, д.6, Бизнес-центр «АВС»

Телефон: +7 495 668-12-70 (многоканальный)

Факс: +7 495 668-12-70 (доб.304)

E-mail: [info@moschip.ru](mailto:info@moschip.ru)

Skype отдела продаж:

moschip.ru_3	moschip.ru_6
moschip.ru_4	moschip.ru_7
moschip.ru_11	moschip.ru_8
moschip.ru_12	moschip.ru_9