

LC717A30URGEVK

LC717A30URGEVK Electrostatic Capacitive Sensor Evaluation Kit User's Manual



ON Semiconductor®

www.onsemi.com

EVAL BOARD USER'S MANUAL

Contents

The electrostatic capacitive sensor evaluation kit (LC717A30URGEVK) has both several evaluation boards to evaluate the operation of various switch patterns and the communication facility for PC because of changing some registers. This manual explains configuration, usage and specification.

Features

- Capable of Evaluating Using Film Type Electrode Sheet
- Capable of Evaluating Using Customer's Sensor Board
- Communication Module Between This Kit and PC Through USB

Equipment Used

- Electrostatic Capacitive Sensor Evaluation Kit "LC717A30URGEVK"
- PC (Installed GUI and USB Power Supply)

Typical Applications

- Automotive: Smart Key, Control Switches
- Consumer: White Goods
- Industrial: Security Lock
- Computing: PC Peripherals
- Lighting: Remote Control Switches

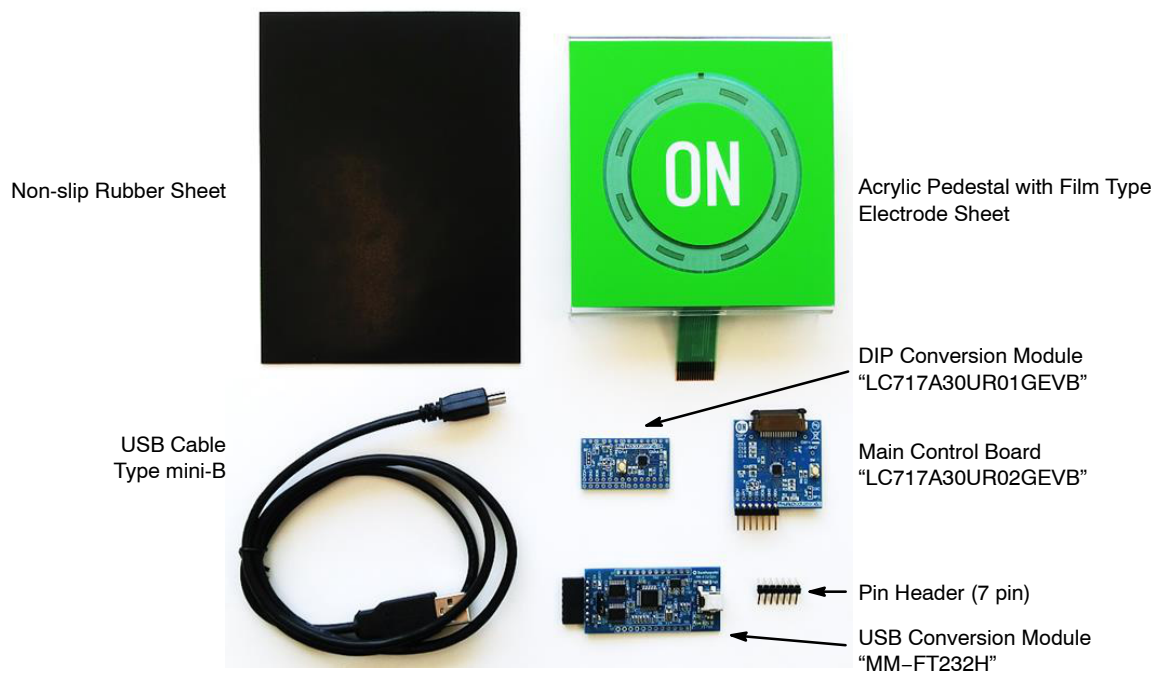

Figure 1. Configuration of the LC717A30URGEVK Evaluation Kit

GETTING STARTED

Install the Evaluation Software (GUI)

Copy LC717A30 executable evaluation software “LC717A30AppV2.exe” (hereinafter this is called “the application software”) to any folder on your PC. In addition, unzip the parameter file (e.g. LC717A30URGEVKV2_PARAMETER.ZIP) from this evaluation kit website and store it in the same folder as the GUI software.

Install the Device Driver

Download the device driver from the following URL and install it into your PC.

FTDI official web page: <http://www.ftdichip.com/>.

FTDI Chip Future Technology Devices International Ltd. THE USB BRIDGING SOLUTIONS SPECIALISTS

Home Products Drivers Firmware Support Android EVE MCU Sales Network Web Shop Newsletter Corporate Contact Us

Latest Update

Click “Drivers”

Drivers

PLEASE NOTE - When updating drivers, refer to the following document: [ANL16](#)

New drivers are now available to support the [FT4222H](#) - for D2XX drivers pl

Click “D2XX Drivers”

Operating System	Release Date	x86 (32-bit)	x64 (64-bit)	ARM	MIPS	SH4
Windows*	2017-08-00	2.12.28	3.12.28	-	-	-
Windows RT	2014-07-04	1.0.2	-	-	-	-
Linux	2017-05-29	1.4.6	1.4.6	1.4.6 ARMv6 soft-float 1.4.6 ARMv5 soft-float uClibc 1.4.6 ARMv6 hard-float (suited Raspberry Pi) 1.4.6 ARMv7 hard-float 1.4.6 ARMv8 hard-float	1.4.6 MIPS32 soft-float 1.4.6 MIPS32 hard-float	-

Unzip the zip file after downloading it.

Currently Supported D2XX Drivers:

Figure 2.

Connection Procedure of the Evaluation Board

1. Connect a USB cable to PC.
2. Connect USB cable and USB conversion module (USB dongle).
3. Start LC717A30AppV2.exe of the GUI software.
4. Connect USB conversion module and LC717A30UR's evaluation board.

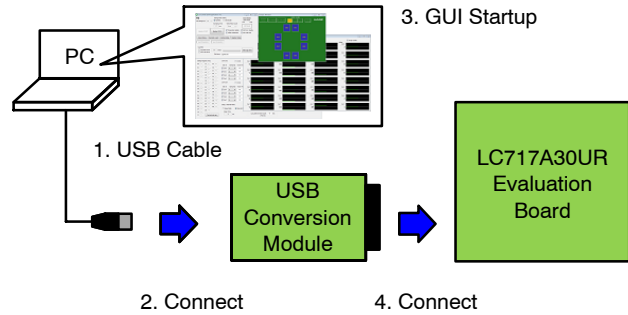

Figure 3.

USB Conversion Module Operation Guide

The USB conversion module (MM-FT232H made in Sunhayato) bundled with this evaluation kit is a conversion module mounted with a multi-functional USB conversion IC (FT232H) made in FTDI. This converts the USB interface into various interfaces. Also, the power supply voltage supplied from the USB port can be output from the connector, and the voltage level can be switched to 3.3 V or 5.0 V by jumper setting.

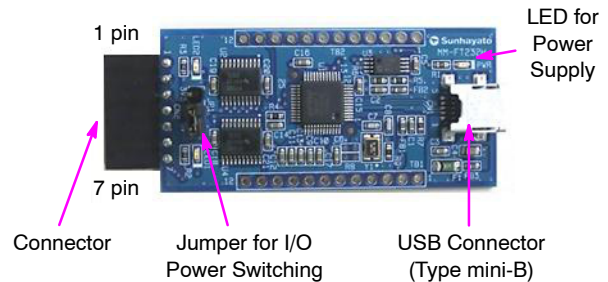

Figure 4.

Table 1. PIN ASSIGNMENT OF CONNECTOR

No.	I ² C I/F Signal Name	SPI I/F Signal Name
1	VDD	VDD
2	GND	GND
3	SCL	SCK
4	SDA	SI
5	SDA (Note 1)	SO
6	N.C. (open)	N.C. (open)
7	N.C. (open)	nCS

1. When using an I²C interface, connect both 4 pin and 5 pin on customer's board side.

LC717A30URGEVK

SETUP

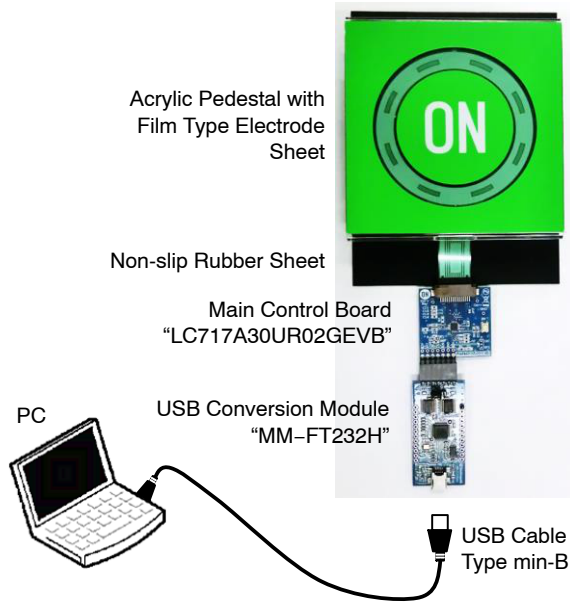

Figure 5.

1. Connect a PC, USB dongle and Main Control Board.

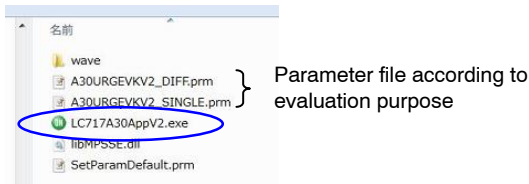

Figure 6.

2. Start LC717A30AppV2.exe of the GUI software.

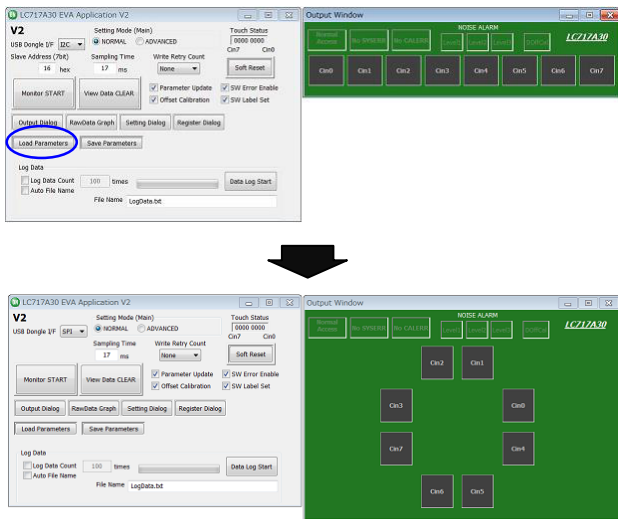

Figure 7.

3. Load a parameter file according to evaluation purpose. (e.g. A30URGEVKV2_SINGLE.prm)

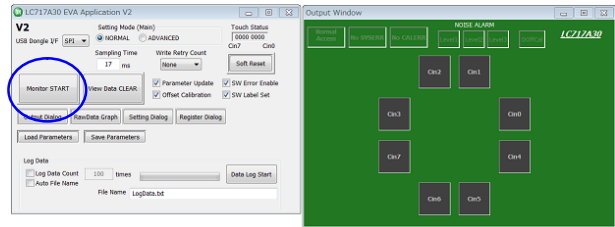

Figure 8.

4. Click the “Monitor START”.

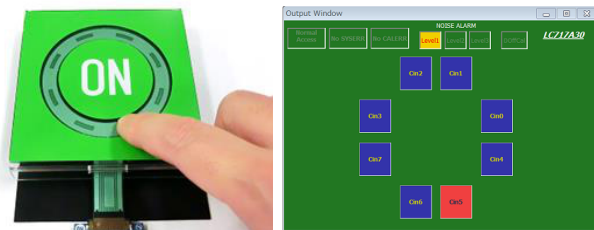

Figure 9.

5. When the finger touches the electrode sheet on the acrylic pedestal, the corresponding channel on the output window is displayed to red.
6. Click the “Monitor STOP” to stop the monitor operation.

- If you click the “Setting Dialog”, the “Initial Setting Window” is displayed and you can confirm the register setting.
- If you click the “RawData Graph”, the “Raw Data Graph Window” is displayed and you can confirm the AD value level waveform.
- The “A30URGEVKV2_SINGLE.prm” parameter file is set to measure in single mode with the AmpMode of the Control 3 Register (0x2B) set to “1”.
- The “A30URGEVKV2_DIFF.prm” parameter file is set to measure in differential mode with the AmpMode of the Control 3 Register (0x2B) set to “0”.

LC717A30URGEVK

MAIN CONTROL BOARD FUNCTINS

Configuration (LC717A30UR02GEVB)

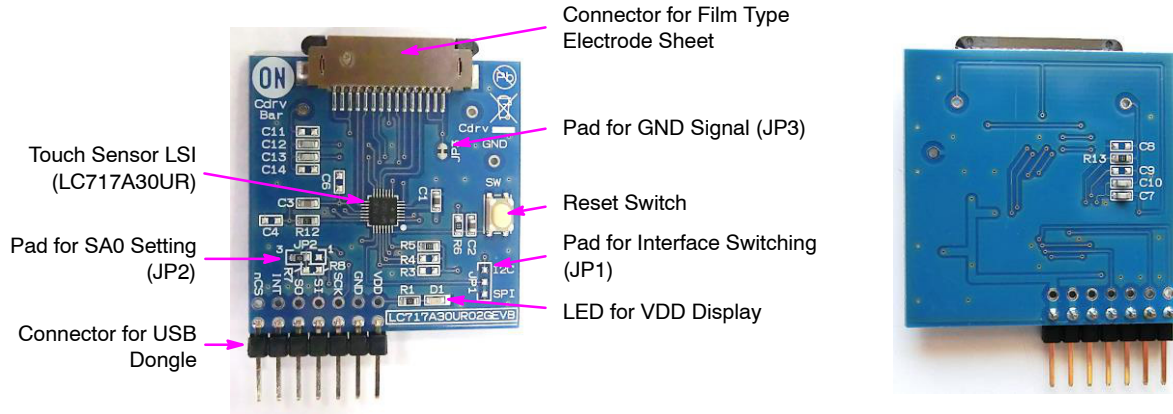

Figure 10. Configuration of the Main Control Board

The communication interface can be switched to I²C or SPI according to the JP1, JP2, R3, R4, R7 and R8 mount

conditions on this evaluation board. The initial state is set to SPI mode.

Table 2. MOUNT CONDITIONS OF THE MAIN CONTROL BOARD

Designator	I ² C Mode	SPI Mode (Initial Setting)
R3	3.3 k Ω	Unmount (Open)
R4	3.3 k Ω	Unmount (Open)
R7	Unmount (Open)	0 Ω
R8	0 Ω	Unmount (Open)
JP2 (1-2)	100 k Ω (SA0=1)	Unmount (Open)
JP2 (2-3)	100 k Ω (SA0=0)	100 k Ω
JP1	I ² C	SPI

LC717A30URGEVK

Schematic (LC717A30UR02GEVB)

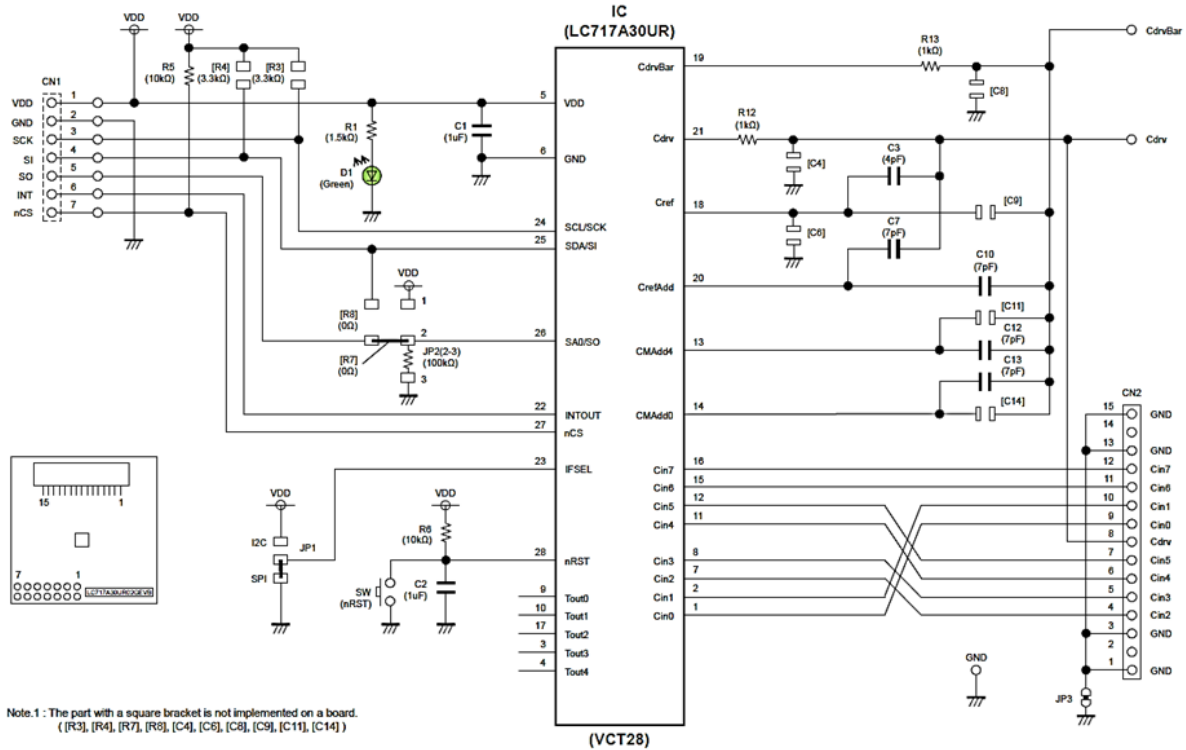

Figure 11. Schematic of the Main Control Board

Bill of Materials (LC717A30UR02GEVB)

Table 3. BILL OF MATERIALS OF LC717A30UR02GEVB EVALUATION BOARD

Designator	Qty.	Description	Part Number	Value	Manufacturer
IC	1	Capacitive touch sensors LSI	LC717A30UR	8ch, VCT28	ON Semiconductor
D1	1	LED	SML-512MW	Green LED	ROHM
R12, R13	2	Resistor	RK73B1JTTD102J	1 kΩ ±5%, 0.125 W	KOA
R1	1	Resistor	RK73B1JTTD152J	1.5 kΩ ±5%, 0.125 W	KOA
R5, R6	2	Resistor	RK73B1JTTD103J	10 kΩ ±5%, 0.125 W	KOA
JP2 (2-3)	1	Resistor	RK73B1JTTD104J	100 kΩ ±5%, 0.125 W	KOA
C3	1	Multilayer ceramic capacitor	GRM1885C1H4R0C	4 pF ±0.25 pF, 50 V	Murata
C7, C10, C12, C13	4	Multilayer ceramic capacitor	GRM1885C1H7R0C	7 pF ±0.25 pF, 50 V	Murata
C1, C2	1	Multilayer ceramic capacitor	TMK107BJ105K	1 μF ±10%, 25 V	TAIYO YUDEN
SW	1	Push button switch	SKRSPACE010		ALPS ELECTRIC
CN1	1	Connector	PSR-410256-07	7 pin, Right angle	Hirosugi Keiki
CN2	1	FFC/FPC Connector	08 6224 015 002 800+	15 pin, Right angle	Kyocera Connector Products

LC717A30URGEVK

Printed Circuit Board Layout (LC717A30UR02GEVB)

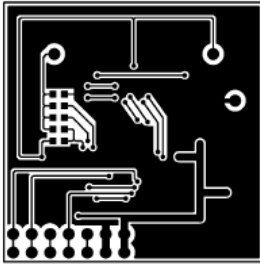

Figure 12. Pattern 1 Layer (Solder Side)

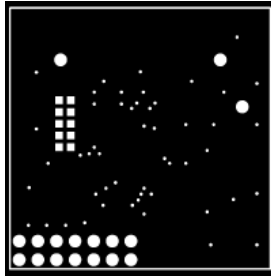

Figure 13. Resist 1 Layer (Solder Side)

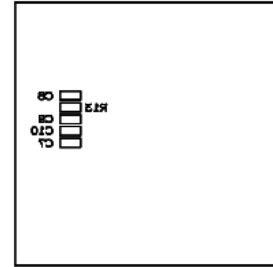

Figure 14. Silk 1 Layer (Solder Side)

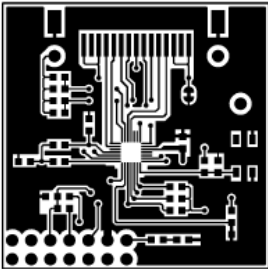

Figure 15. Pattern 2 Layer (Parts Side)

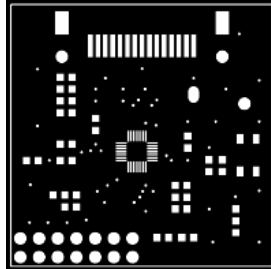

Figure 16. Resist 2 Layer (Parts Side)

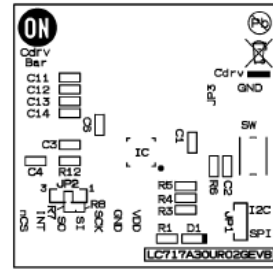

Figure 17. Silk 2 Layer (Parts Side)

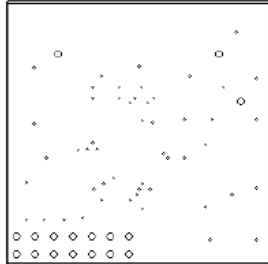

Figure 18. Hole

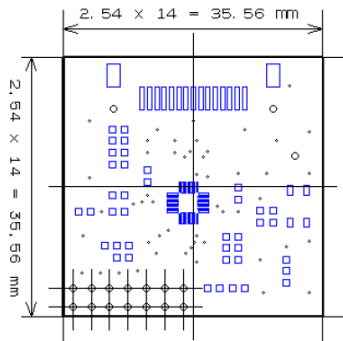

Figure 19. Outline

LC717A30URGEVK

DIP CONVERSION BOARD FUNCTIONS

Configuration (LC717A30UR01GEVB)

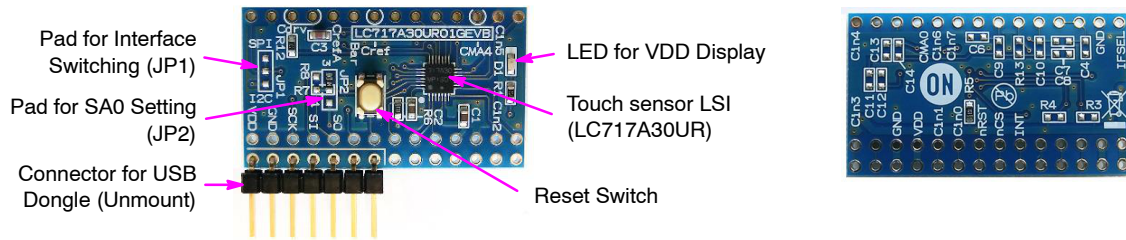

Figure 20. Configuration of the DIP Conversion Board

The communication interface can be switched to I²C or SPI according to the JP1, JP2, R3, R4, R7 and R8 mount conditions on this evaluation board. The initial state is set to SPI mode.

Table 4. MOUNT CONDITIONS OF THE DIP CONVERSION BOARD

Designator	I ² C Mode	SPI Mode (Initial Setting)
R3	3.3 k Ω	Unmount (Open)
R4	3.3 k Ω	Unmount (Open)
R7	Unmount (Open)	0 Ω
R8	0 Ω	Unmount (Open)
JP2 (1-2)	100 k Ω (SA0=1)	Unmount (Open)
JP2 (2-3)	100 k Ω (SA0=0)	100 k Ω
JP1	I ² C	SPI

LC717A30URGEVK

Schematic (LC717A30UR01GEVB)

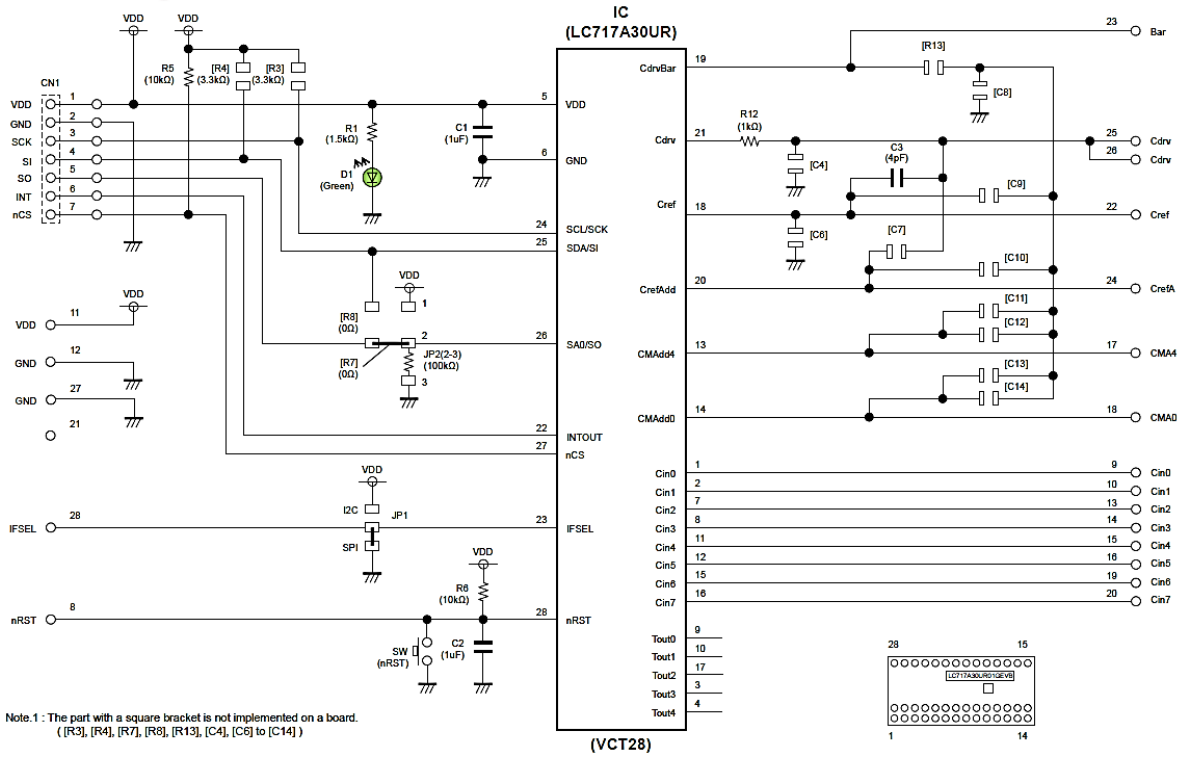

Figure 21. Schematic of the DIP Conversion Board

Bill of Materials (LC717A30UR01GEVB)

Table 5. BILL OF MATERIALS OF LC717A30UR01GEVB EVALUATION BOARD

Designator	Qty.	Description	Part Number	Value	Manufacturer
IC	1	Capacitive touch sensors LSI	LC717A30UR	8ch, VCT28	ON Semiconductor
D1	1	LED	SML-512MW	Green LED	ROHM
R12	1	Resistor	RK73B1JTTD102J	1 kΩ ±5%, 0.125 W	KOA
R1	1	Resistor	RK73B1JTTD152J	1.5 kΩ ±5%, 0.125 W	KOA
R5, R6	2	Resistor	RK73B1JTTD103J	10 kΩ ±5%, 0.125 W	KOA
JP2 (2-3)	1	Resistor	RK73B1JTTD104J	100 kΩ ±5%, 0.125 W	KOA
C3	1	Multilayer ceramic capacitor	GRM1885C1H4R0C	4 pF ±0.25 pF, 50 V	Murata
C1, C2	1	Multilayer ceramic capacitor	TMK107BJ105K	1 μF ±10%, 25 V	TAIYO YUDEN
SW	1	Push button switch	SKRSPACE010		ALPS ELECTRIC

LC717A30URGEVK

Printed Circuit Board Layout (LC717A30UR01GEVB)

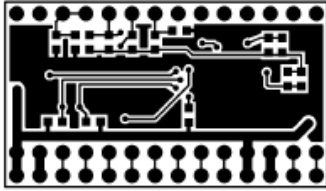

Figure 22. Pattern 1 Layer (Solder Side)

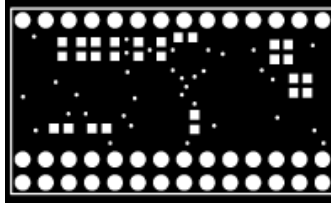

Figure 23. Resist 1 Layer (Solder Side)

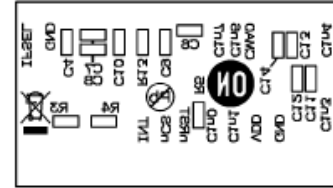

Figure 24. Silk 1 Layer (Solder Side)

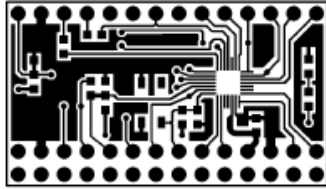

Figure 25. Pattern 2 Layer (Parts Side)

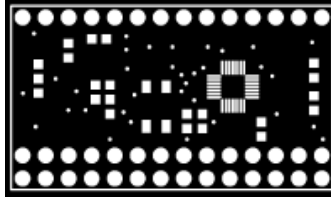

Figure 26. Resist 2 Layer (Parts Side)

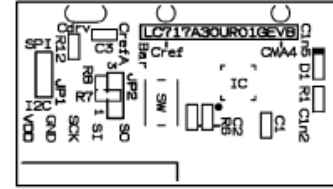

Figure 27. Silk 2 Layer (Parts Side)

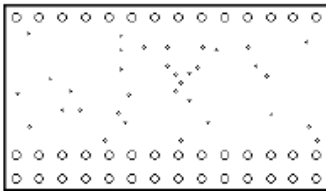

Figure 28. Hole

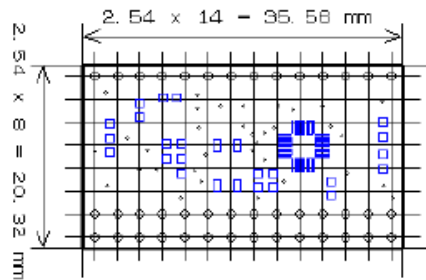

Figure 29. Outline

LC717A30URGEVK

FILM TYPE ELECTRODE SHEET

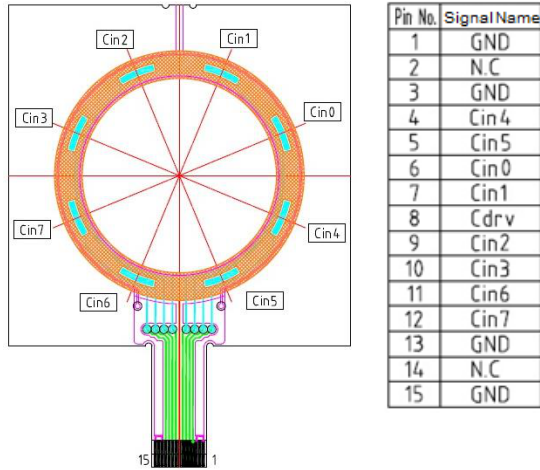

Figure 30. Pin Assignment of Connector

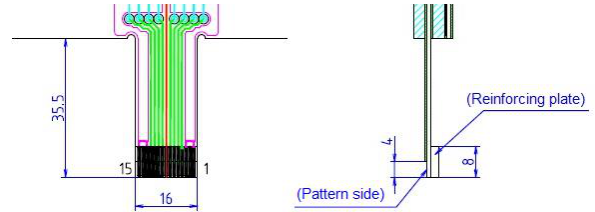

Figure 31. Connector Part Size

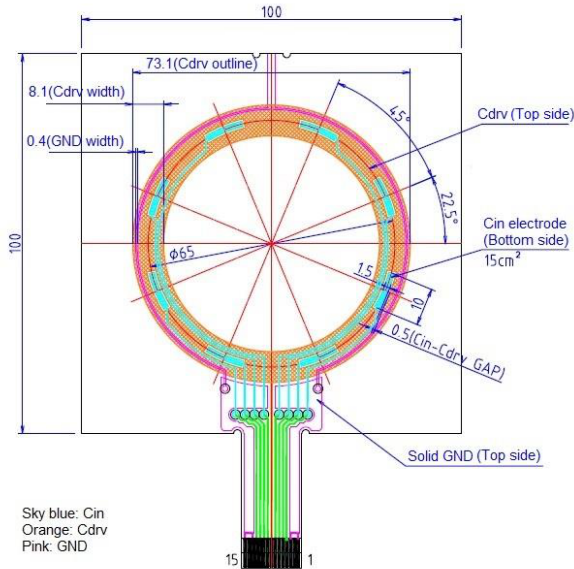

Figure 32. Sensor Electrode Size

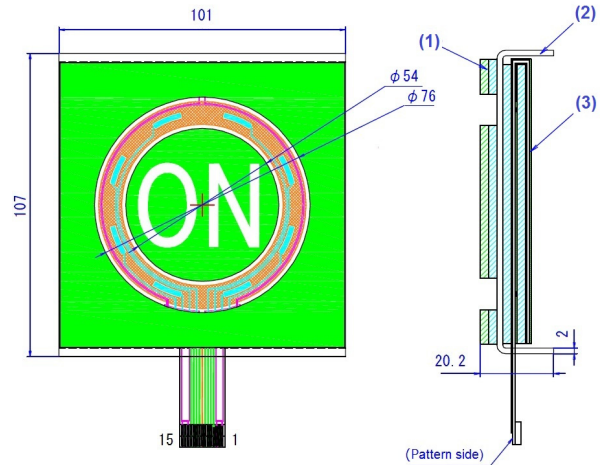

Figure 33. Acrylic Pedestal Part Size

Table 6. BILL OF MATERIALS OF SENSORS SHEET

Designator	Qty.	Description	Part Number	Value	Manufacturer
(1)	1	Top sheet	ANK-0021F1		K&D Co., Ltd.
(2)	1	Acrylic		Clear, t = 2.0 mm	K&D Co., Ltd.
(3)	1	Sensors electrode sheet	ANK-0021S1-3		K&D Co., Ltd.

NOTE: For more information about K&D Co., Ltd., please see the <https://www.kandd.co.jp/> website.

NOTE

Refer to the application-note on ON Semiconductor touch sensor page for sensor patterns of the design rule and usage of LSI. And, refer to the user's manual of the application-software for usage of the software and installing the device driver.

ON Semiconductor and the ON Semiconductor logo are trademarks of Semiconductor Components Industries, LLC dba ON Semiconductor or its subsidiaries in the United States and/or other countries. ON Semiconductor owns the rights to a number of patents, trademarks, copyrights, trade secrets, and other intellectual property. A listing of ON Semiconductor's product/patent coverage may be accessed at www.onsemi.com/site/pdf/Patent-Marking.pdf. ON Semiconductor is an Equal Opportunity/Affirmative Action Employer. This literature is subject to all applicable copyright laws and is not for resale in any manner.

The evaluation board/kit (research and development board/kit) (hereinafter the "board") is not a finished product and is as such not available for sale to consumers. The board is only intended for research, development, demonstration and evaluation purposes and should as such only be used in laboratory/development areas by persons with an engineering/technical training and familiar with the risks associated with handling electrical/mechanical components, systems and subsystems. This person assumes full responsibility/liability for proper and safe handling. Any other use, resale or redistribution for any other purpose is strictly prohibited.

The board is delivered "AS IS" and without warranty of any kind including, but not limited to, that the board is production-worthy, that the functions contained in the board will meet your requirements, or that the operation of the board will be uninterrupted or error free. ON Semiconductor expressly disclaims all warranties, express, implied or otherwise, including without limitation, warranties of fitness for a particular purpose and non-infringement of intellectual property rights.

ON Semiconductor reserves the right to make changes without further notice to any board.

You are responsible for determining whether the board will be suitable for your intended use or application or will achieve your intended results. Prior to using or distributing any systems that have been evaluated, designed or tested using the board, you agree to test and validate your design to confirm the functionality for your application. Any technical, applications or design information or advice, quality characterization, reliability data or other services provided by ON Semiconductor shall not constitute any representation or warranty by ON Semiconductor, and no additional obligations or liabilities shall arise from ON Semiconductor having provided such information or services.

The boards are not designed, intended, or authorized for use in life support systems, or any FDA Class 3 medical devices or medical devices with a similar or equivalent classification in a foreign jurisdiction, or any devices intended for implantation in the human body. Should you purchase or use the board for any such unintended or unauthorized application, you shall indemnify and hold ON Semiconductor and its officers, employees, subsidiaries, affiliates, and distributors harmless against all claims, costs, damages, and expenses, and reasonable attorney fees arising out of, directly or indirectly, any claim of personal injury or death associated with such unintended or unauthorized use, even if such claim alleges that ON Semiconductor was negligent regarding the design or manufacture of the board.

This evaluation board/kit does not fall within the scope of the European Union directives regarding electromagnetic compatibility, restricted substances (RoHS), recycling (WEEE), FCC, CE or UL, and may not meet the technical requirements of these or other related directives.

FCC WARNING – This evaluation board/kit is intended for use for engineering development, demonstration, or evaluation purposes only and is not considered by ON Semiconductor to be a finished end product fit for general consumer use. It may generate, use, or radiate radio frequency energy and has not been tested for compliance with the limits of computing devices pursuant to part 15 of FCC rules, which are designed to provide reasonable protection against radio frequency interference. Operation of this equipment may cause interference with radio communications, in which case the user shall be responsible, at its expense, to take whatever measures may be required to correct this interference.

ON Semiconductor does not convey any license under its patent rights nor the rights of others.

LIMITATIONS OF LIABILITY: ON Semiconductor shall not be liable for any special, consequential, incidental, indirect or punitive damages, including, but not limited to the costs of requalification, delay, loss of profits or goodwill, arising out of or in connection with the board, even if ON Semiconductor is advised of the possibility of such damages. In no event shall ON Semiconductor's aggregate liability from any obligation arising out of or in connection with the board, under any theory of liability, exceed the purchase price paid for the board, if any.

For more information and documentation, please visit www.onsemi.com.

PUBLICATION ORDERING INFORMATION

LITERATURE FULFILLMENT:

Email Requests to: orderlit@onsemi.com

ON Semiconductor Website: www.onsemi.com

TECHNICAL SUPPORT

North American Technical Support:

Voice Mail: 1 800-282-9855 Toll Free USA/Canada

Phone: 011 421 33 790 2910

Europe, Middle East and Africa Technical Support:

Phone: 00421 33 790 2910

For additional information, please contact your local Sales Representative

Данный компонент на территории Российской Федерации

Вы можете приобрести в компании MosChip.

Для оперативного оформления запроса Вам необходимо перейти по данной ссылке:

<http://moschip.ru/get-element>

Вы можете разместить у нас заказ для любого Вашего проекта, будь то серийное производство или разработка единичного прибора.

В нашем ассортименте представлены ведущие мировые производители активных и пассивных электронных компонентов.

Нашей специализацией является поставка электронной компонентной базы двойного назначения, продукции таких производителей как XILINX, Intel (ex.ALTERA), Vicor, Microchip, Texas Instruments, Analog Devices, Mini-Circuits, Amphenol, Glenair.

Сотрудничество с глобальными дистрибьюторами электронных компонентов, предоставляет возможность заказывать и получать с международных складов практически любой перечень компонентов в оптимальные для Вас сроки.

На всех этапах разработки и производства наши партнеры могут получить квалифицированную поддержку опытных инженеров.

Система менеджмента качества компании отвечает требованиям в соответствии с ГОСТ Р ИСО 9001, ГОСТ РВ 0015-002 и ЭС РД 009

Офис по работе с юридическими лицами:

105318, г.Москва, ул.Щербаковская д.3, офис 1107, 1118, ДЦ «Щербаковский»

Телефон: +7 495 668-12-70 (многоканальный)

Факс: +7 495 668-12-70 (доб.304)

E-mail: info@moschip.ru

Skype отдела продаж:

moschip.ru

moschip.ru_4

moschip.ru_6

moschip.ru_9