



SANYO Semiconductors

## DATA SHEET

# LA6585T — Monolithic Linear IC

## BTL Drive Single-Phase Full-Wave Fan Motor Driver

### Overview

The LA6585T is a single-phase bipolar fan motor driver that achieves quiet operation, power savings, silent operation and high efficiency that suppresses reactive current through BTL output linear drive. It provides lock protection and rotation signal circuits on chip, and is optimal for applications that require high reliability and low noise, such as notebook personal computers, power supplies in consumer electronic equipment, car audio, and CPU cooling systems.

### Features

- BTL output single-phase full-wave linear drive (gain resistor : 1 to 360k $\Omega$ , 51dB)
- Supports low-voltage drive and features a wide usable voltage range (2.2 to 14.0V)
- Low saturation output (high side + low side saturation voltage : Vosat (total) = 1.2V (typical), I<sub>O</sub> = 250mA)
- Built-in lock protection and automatic return circuits
- Built-in FG output
- Built-in Hall sensor bias (VHB = 1.5V)
- Thermal protection circuit
- Small-sized, high thermal capacity package

### Specifications

#### Absolute Maximum Ratings at T<sub>a</sub> = 25°C

Parameter	Symbol	Conditions	Ratings	Unit
Supply voltage	V <sub>CC</sub> max		15	V
Output current	I <sub>OUT</sub> max		0.5	A
Output voltage	V <sub>OUT</sub> max		15	V
FG output pin output withstand voltage	V <sub>FG</sub> max		15	V
FG output current	I <sub>FG</sub> max		10	mA

Continued on next page.

■ Any and all SANYO Semiconductor Co.,Ltd. products described or contained herein are, with regard to "standard application", intended for the use as general electronics equipment (home appliances, AV equipment, communication device, office equipment, industrial equipment etc.). The products mentioned herein shall not be intended for use for any "special application" (medical equipment whose purpose is to sustain life, aerospace instrument, nuclear control device, burning appliances, transportation machine, traffic signal system, safety equipment etc.) that shall require extremely high level of reliability and can directly threaten human lives in case of failure or malfunction of the product or may cause harm to human bodies, nor shall they grant any guarantee thereof. If you should intend to use our products for applications outside the standard applications of our customer who is considering such use and/or outside the scope of our intended standard applications, please consult with us prior to the intended use. If there is no consultation or inquiry before the intended use, our customer shall be solely responsible for the use.

■ Specifications of any and all SANYO Semiconductor Co.,Ltd. products described or contained herein stipulate the performance, characteristics, and functions of the described products in the independent state, and are not guarantees of the performance, characteristics, and functions of the described products as mounted in the customer's products or equipment. To verify symptoms and states that cannot be evaluated in an independent device, the customer should always evaluate and test devices mounted in the customer's products or equipment.

**SANYO Semiconductor Co., Ltd.**

TOKYO OFFICE Tokyo Bldg., 1-10, 1 Chome, Ueno, Taito-ku, TOKYO, 110-8534 JAPAN

# LA6585T

Continued from preceding page.

Parameter	Symbol	Conditions	Ratings	Unit
Allowable power dissipation	Pd max	When mounted on a circuit board *1	400	mW
Operating temperature	Topr		-30 to +90	°C
Storage temperature	Tstg		-55 to +150	°C

\*1 Specified circuit board : 114.3 × 76.1 × 1.6mm<sup>3</sup>, glass epoxy.

## Recommended Operating Conditions at Ta = 25°C

Parameter	Symbol	Conditions	Ratings	Unit
Supply voltage	V <sub>CC</sub>		2.2 to 14.0	V
Common-phase input voltage range of hall input	V <sub>ICM</sub>		0 to V <sub>CC</sub> - 1.5	V

## Electrical Characteristics at Ta = 25°C, V<sub>CC</sub> = 12V, Unless otherwise specified.

Parameter	Symbol	Conditions	Ratings			Unit
			min	typ	max	
Circuit current	I <sub>CC1</sub>	Drive mode (CT = low)	3	6	9	mA
	I <sub>CC2</sub>	Lock protection mode (CT = high)	2.5	5	7.5	mA
Lock detection capacitor charge current	I <sub>CT1</sub>		0.9	1.2	1.5	μA
Capacitor discharge current	I <sub>CT2</sub>		0.10	0.18	0.25	μA
Capacitor charge/discharge current ratio	RCT	RCD = I <sub>CT1</sub> /I <sub>CT2</sub>	5	6.5	8	
CT charge voltage	V <sub>CT1</sub>		1.3	1.5	1.7	V
CT discharge voltage	V <sub>CT2</sub>		0.3	0.5	0.7	V
OUT output low saturation voltage	V <sub>OL</sub>	I <sub>O</sub> = 200mA		0.25	0.45	V
OUT output high saturation voltage	V <sub>OH</sub>	I <sub>O</sub> = 200mA		0.95	1.2	V
Hall input sensitivity	V <sub>HN</sub>	Zero peak value (including offset and hysteresis)		7	15	mV
FG output pin low-level voltage	V <sub>FG</sub>	I <sub>FG</sub> = 5mA		0.15	0.3	V
FG output pin leakage current	I <sub>FG</sub>	V <sub>FG</sub> = 15V		1	30	μA

## Package Dimensions

unit : mm (typ)

3245B

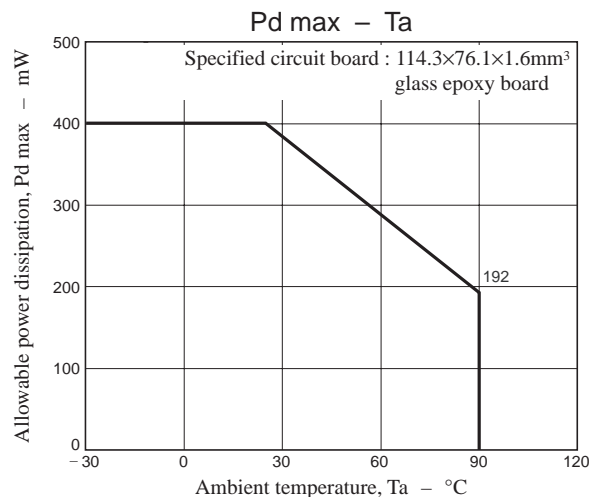
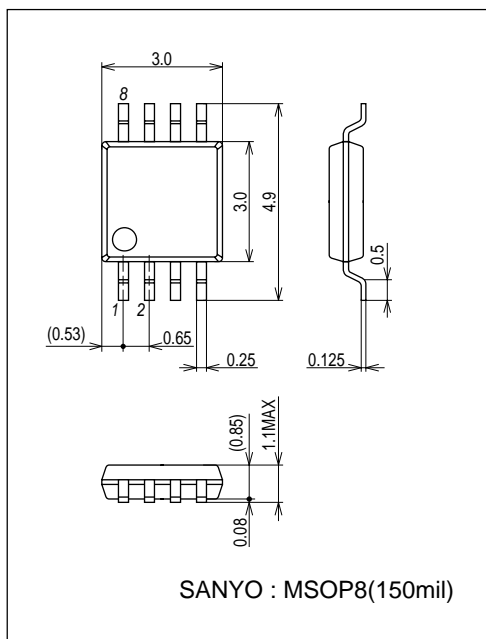

# LA6585T

## Truth Table

IN-	IN+	CT	OUT1	OUT2	FG	Mode
High	Low	Low	High	Low	Low	During rotation
Low	High		Low	High	High	
-	-	High	Off	Off	-	Lock protection

## Pin Assignment

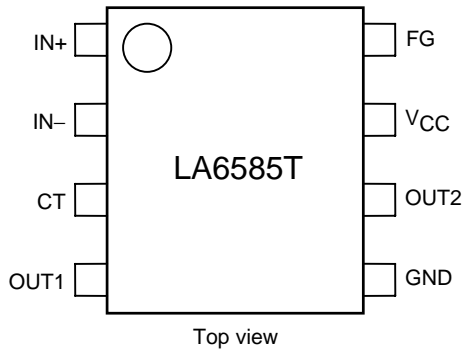

## Application Circuit Example

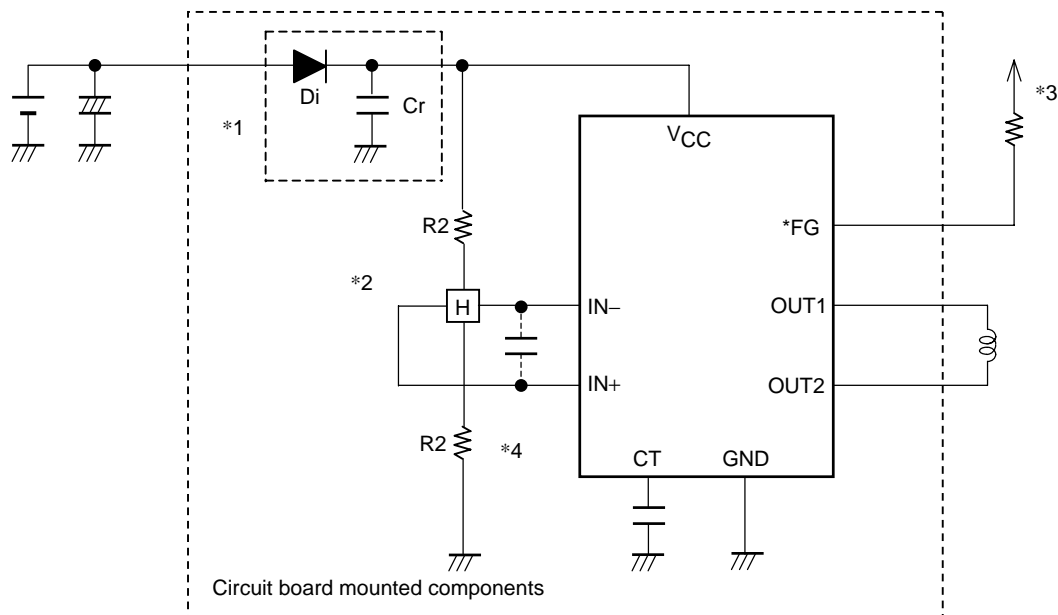

- \*1. If the diode Di (which protects the IC destruction by reverse connection) is used, it is necessary to insert the capacitor Cr and provide a regenerative current route. Similarly, if there is no nearby capacitor on the fan power supply line, Cr will also be necessary to improve reliability.
- \*2. If the Hall sensor bias is taken from VCC, a  $1/2 V_{CC}$  bias, as shown in the figure, must be used. Linear drive is implemented by amplifying the Hall sensor output and applying voltage control to the coil. If the Hall effect sensor provides a strong output, the startup characteristics and efficiency will be good, then even quieter operation will be achieved by adjusting the Hall effect sensor.
- \*3. This pin must be left open if unused.
- \*4. If the line from the Hall sensor output to the Hall sensor input of IC are long, noise may enter the system from that line. If that becomes a problem, insert a capacitor as shown in the figure.

Internal Equivalent Circuits

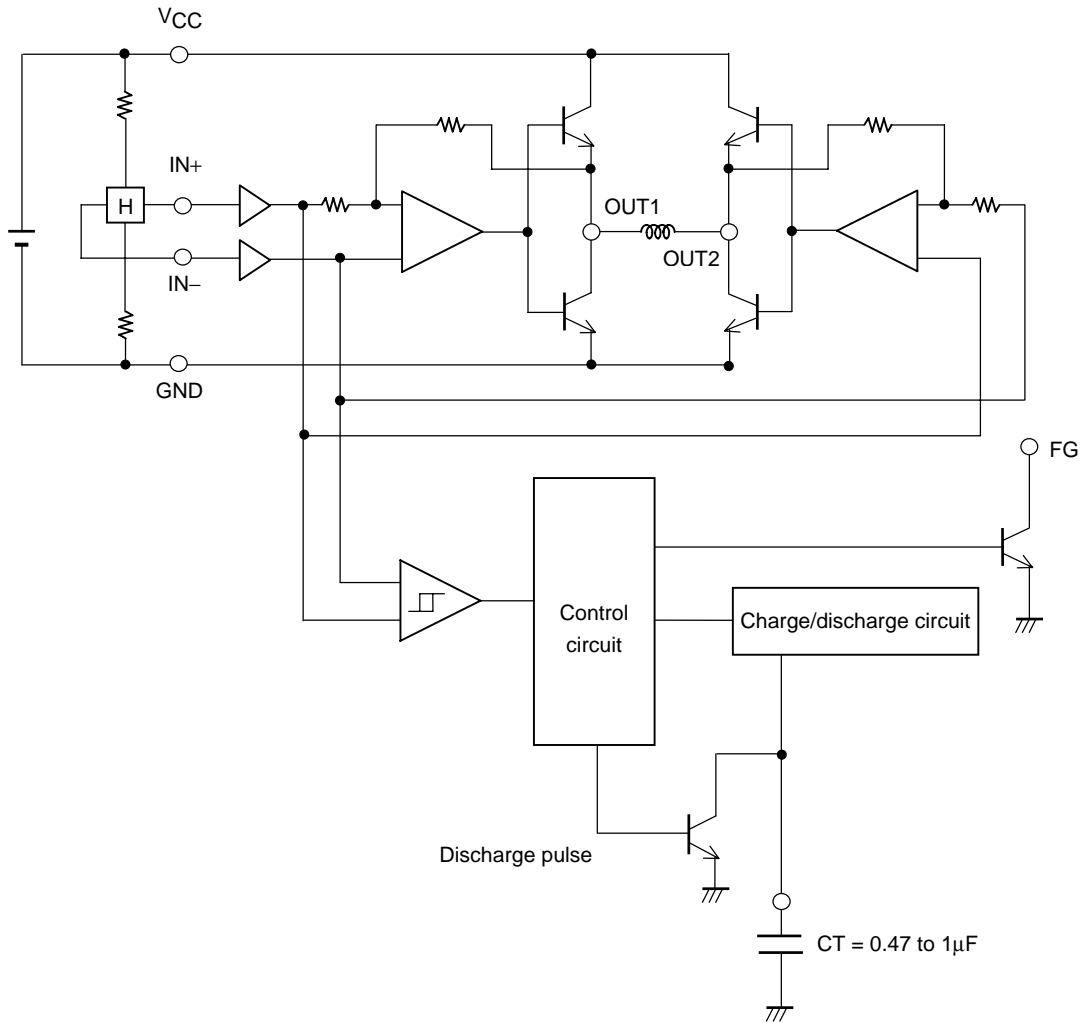

- SANYO Semiconductor Co.,Ltd. assumes no responsibility for equipment failures that result from using products at values that exceed, even momentarily, rated values (such as maximum ratings, operating condition ranges, or other parameters) listed in products specifications of any and all SANYO Semiconductor Co.,Ltd. products described or contained herein.
- SANYO Semiconductor Co.,Ltd. strives to supply high-quality high-reliability products, however, any and all semiconductor products fail or malfunction with some probability. It is possible that these probabilistic failures or malfunction could give rise to accidents or events that could endanger human lives, trouble that could give rise to smoke or fire, or accidents that could cause damage to other property. When designing equipment, adopt safety measures so that these kinds of accidents or events cannot occur. Such measures include but are not limited to protective circuits and error prevention circuits for safe design, redundant design, and structural design.
- In the event that any or all SANYO Semiconductor Co.,Ltd. products described or contained herein are controlled under any of applicable local export control laws and regulations, such products may require the export license from the authorities concerned in accordance with the above law.
- No part of this publication may be reproduced or transmitted in any form or by any means, electronic or mechanical, including photocopying and recording, or any information storage or retrieval system, or otherwise, without the prior written consent of SANYO Semiconductor Co.,Ltd.
- Any and all information described or contained herein are subject to change without notice due to product/technology improvement, etc. When designing equipment, refer to the "Delivery Specification" for the SANYO Semiconductor Co.,Ltd. product that you intend to use.
- Information (including circuit diagrams and circuit parameters) herein is for example only; it is not guaranteed for volume production.
- Upon using the technical information or products described herein, neither warranty nor license shall be granted with regard to intellectual property rights or any other rights of SANYO Semiconductor Co.,Ltd. or any third party. SANYO Semiconductor Co.,Ltd. shall not be liable for any claim or suits with regard to a third party's intellectual property rights which has resulted from the use of the technical information and products mentioned above.

This catalog provides information as of May, 2007. Specifications and information herein are subject to change without notice.

## Данный компонент на территории Российской Федерации

### Вы можете приобрести в компании MosChip.

Для оперативного оформления запроса Вам необходимо перейти по данной ссылке:

<http://moschip.ru/get-element>

Вы можете разместить у нас заказ для любого Вашего проекта, будь то серийное производство или разработка единичного прибора.

В нашем ассортименте представлены ведущие мировые производители активных и пассивных электронных компонентов.

Нашей специализацией является поставка электронной компонентной базы двойного назначения, продукции таких производителей как XILINX, Intel (ex.ALTERA), Vicor, Microchip, Texas Instruments, Analog Devices, Mini-Circuits, Amphenol, Glenair.

Сотрудничество с глобальными дистрибьюторами электронных компонентов, предоставляет возможность заказывать и получать с международных складов практически любой перечень компонентов в оптимальные для Вас сроки.

На всех этапах разработки и производства наши партнеры могут получить квалифицированную поддержку опытных инженеров.

Система менеджмента качества компании отвечает требованиям в соответствии с ГОСТ Р ИСО 9001, ГОСТ РВ 0015-002 и ЭС РД 009

### Офис по работе с юридическими лицами:

105318, г.Москва, ул.Щербаковская д.3, офис 1107, 1118, ДЦ «Щербаковский»

Телефон: +7 495 668-12-70 (многоканальный)

Факс: +7 495 668-12-70 (доб.304)

E-mail: [info@moschip.ru](mailto:info@moschip.ru)

Skype отдела продаж:

moschip.ru

moschip.ru\_4

moschip.ru\_6

moschip.ru\_9