

## LT1994 Low Noise, Low Distortion, Fully Differential Amplifier/Driver

### DESCRIPTION

Demonstration circuit 961 features an LT<sup>®</sup>1994, low noise, low distortion, fully differential amplifier. The LT1994 is a high precision, very low noise, low distortion, fully differential input/output amplifier (see Table 1). The LT1994's output common mode voltage is independent of the input common mode voltage, and is adjustable by applying a voltage on the V<sub>OCM</sub> pin. The DC961 board contains an LT1994 amplifier configured as a unity gain differential amplifier with 499Ω feedback and input resistors. Gains greater than one require changing the input resistors to a value lower than 499Ω (refer to Figure 2). In addition, DC961 has surface mount pads and traces for resistors and capacitors for building first and second order fully differential filter circuits. The differential outputs of DC961 can be configured with a first order RC network for driving the differential inputs of an analog-to-digital converter (ADC).

Connection to the differential input and output of a DC961 is through SMA connectors. Onboard jumpers configure the DC961 for dual or single power supply operation. The differential input of a DC961 is AC coupled with 1μF capacitors for ease of use as a dual or a single supply circuit. DC coupling to the DC961 input is provided through the shorting of the input capacitors with 0Ω surface-mount resistor jumpers.

**Table 1. LT1994 Noise and Distortion**

Differential Input Referred Voltage Noise Density	3nV/√RTHz
Distortion, 2V <sub>P-P</sub> Differential Input, V <sub>S</sub> = 3V, f <sub>IN</sub> = 1MHz, R <sub>LOAD</sub> = 800Ω	
2nd Harmonic	99dBc
3rd Harmonic	96dBc

**Design files for this circuit board are available at <http://www.linear.com/demo/DC961B>**

LT, LTC, LTM, Linear Technology and the Linear logo are registered trademarks of Analog Devices, Inc. All other trademarks are the property of their respective owners.

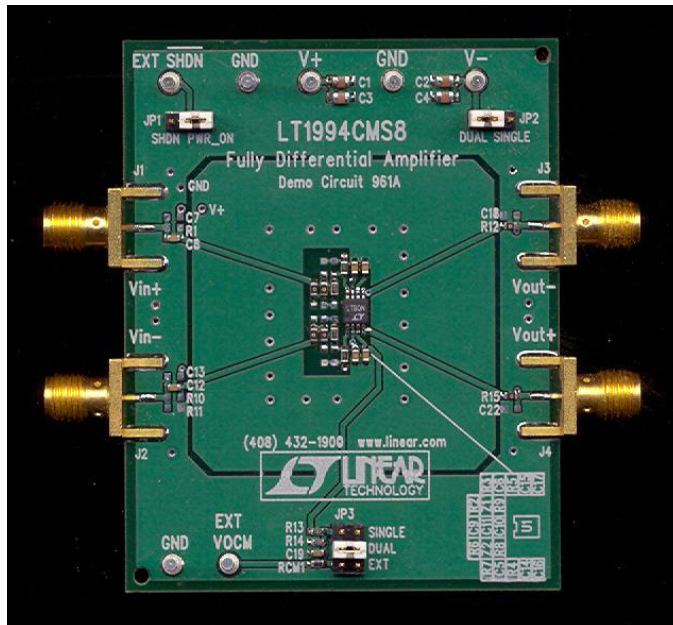

**Figure 1. DC961B**

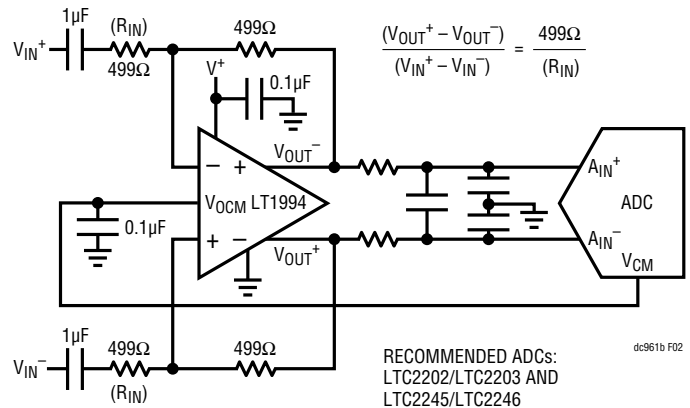

**Figure 2. Typical Application for an LT1994**

## QUICK TEST PROCEDURE

### A. Single-Ended Input to Differential Output

1. Connect to a DC961 a dual power supply, a function generator and an oscilloscope as shown in Figure 3 (the 50Ω termination on J2 input is used to balance the 50Ω generator impedance on J1 input).
2. Set the function generator for a 1V<sub>P-P</sub>, 100kHz sine wave and turn on the power supply.
3. The channel 2 input of the oscilloscope is in phase with the DC961 input and the channel 1 input is 180 degrees out of phase with the DC961 input. The single-ended output shown on channel 1 or 2 is a 0.5V<sub>P-P</sub> sinewave (a 1V<sub>P-P</sub> differential output).

Note 1: The LT1994 can directly drive at least a 25pF capacitive load at each output. However the LT1994 can drive directly a low frequency sinewave (100kHz or less) into a capacitive load of up to 100pF. In this Quick Test Procedure, the output signal is a sinewave and each LT1994 output drives the capacitance of a 24 inch or less cable plus the input capacitance of the oscilloscope input, a capacitive load of 70pF (30pF per foot for the coax cable and 10pF for the oscilloscope input). For testing the transient response of the LT1994 to a squarewave or a pulse, use a 10x low capacitance oscilloscope probe to monitor the DC961 output at J3 or J4.

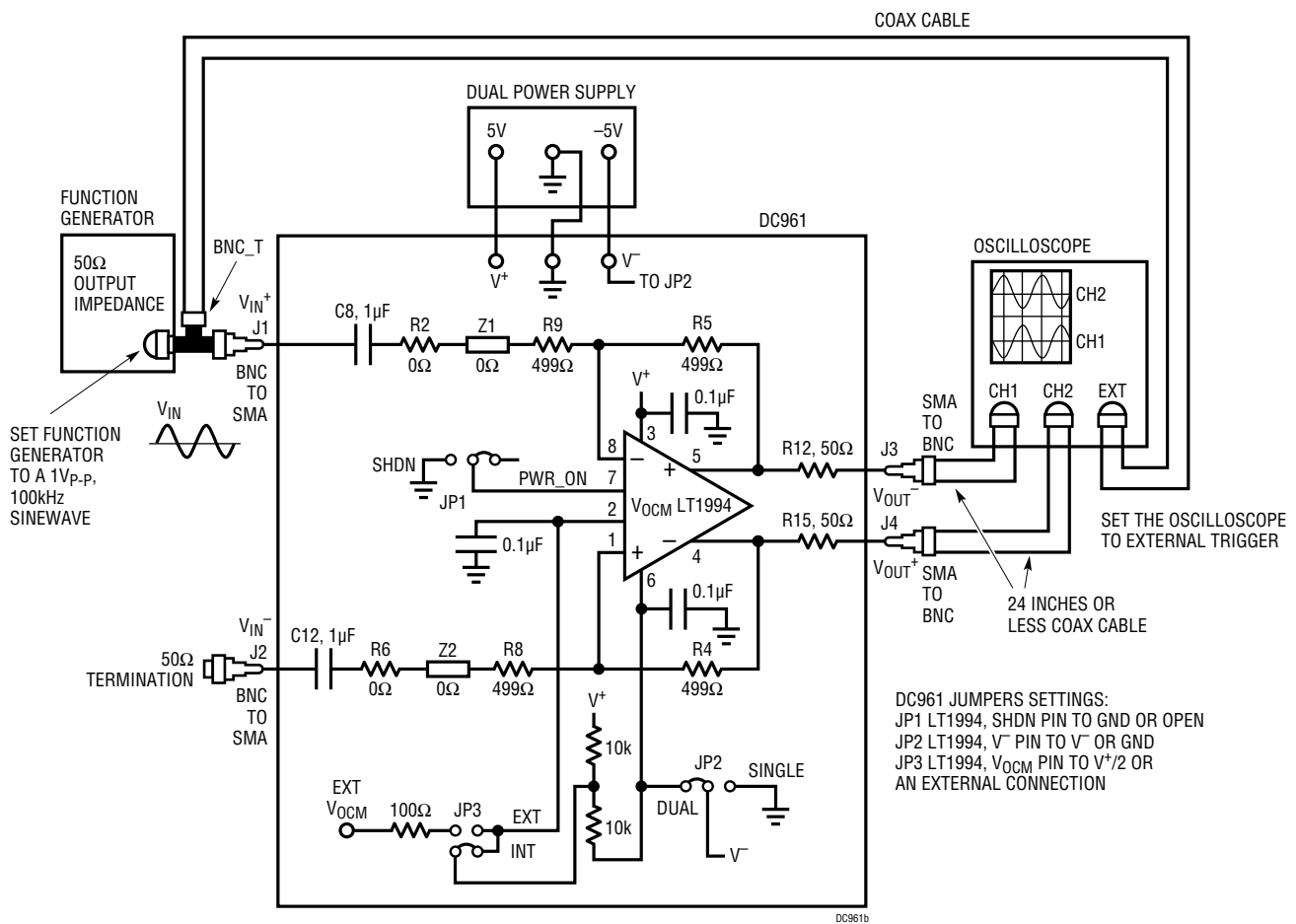
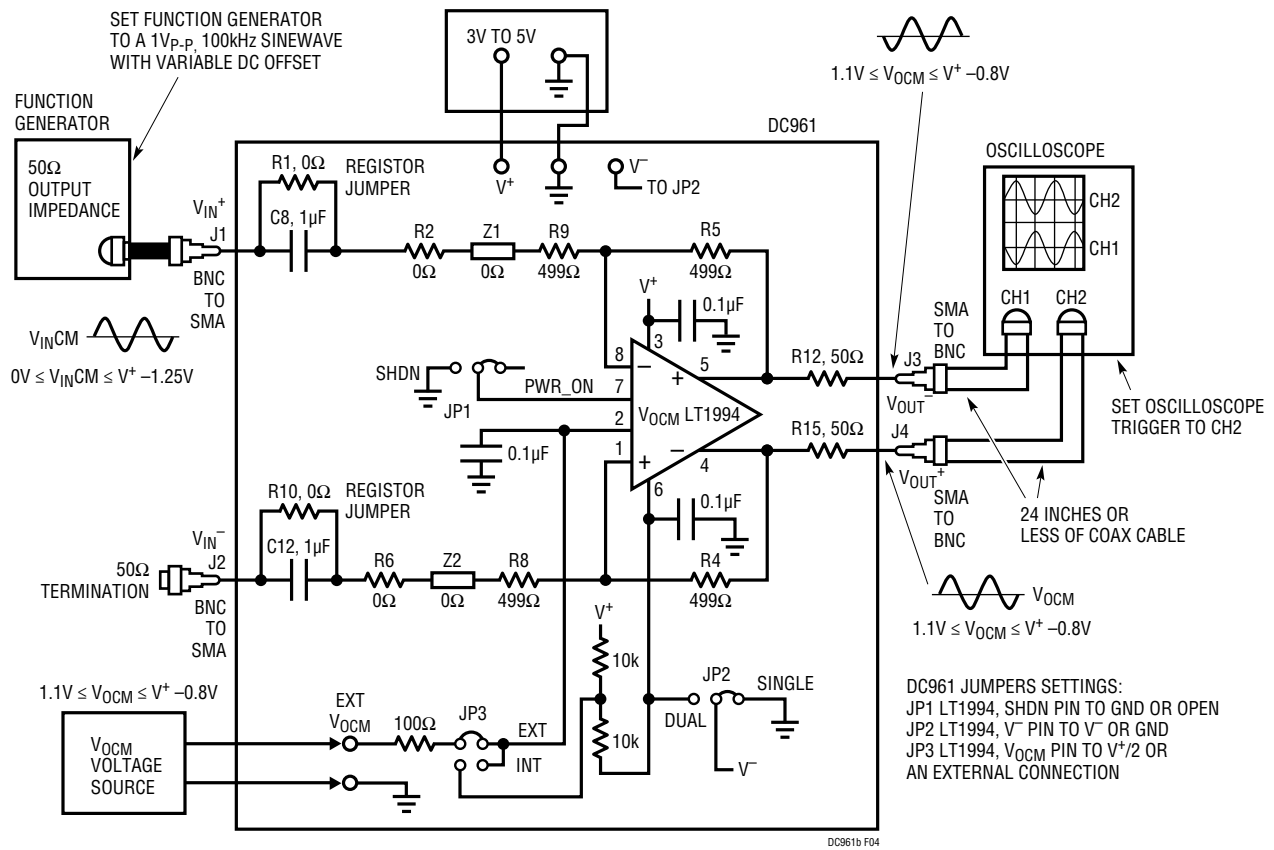

Figure 3. Single-Ended Input to Differential Output Quick Test Setup

**QUICK TEST PROCEDURE**



**Figure 4. Input and Output Common Mode Quick Test Setup**

**B. DC Coupled Inputs and Output Common Mode Voltage Adjustment**

1. On the DC961, install 0603 0Ω resistors at R1 and R10 to short input capacitors C8 and C12 respectively (see DC961 schematic).
2. Connect DC961 as shown in Figure 4 (JP1 to PWR\_ON, JP2 to SINGLE, and JP3 to EXT V<sub>OCM</sub>).

3. Apply an input signal with a DC offset (V<sub>INCM</sub>) 0V to V<sup>+</sup> -1.25V. The output common mode (V<sub>OCM</sub>) can be set independently of the V<sub>INCM</sub> from 1.1V to V<sup>+</sup> -0.8V. This adjustment is made by applying a DC voltage at EXT V<sub>OCM</sub>.

## QUICK TEST PROCEDURE

### C. Driving the Analog Inputs of an ADC

Figure 5 shows the DC961 output components when driving an ADC. Optimum values for the DC961 output components when driving an LTC2202/LTC2203 or LTC2245/LTC2246 ADC.

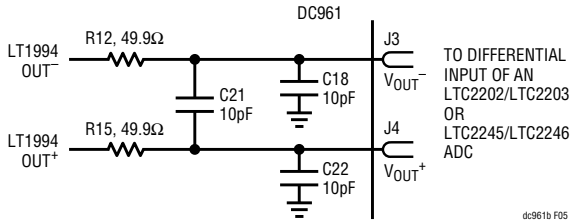

Figure 5. DC961 Output Component Values

### D. Using a DC961 to Implement a Fully Differential, Second Order Lowpass Filter.

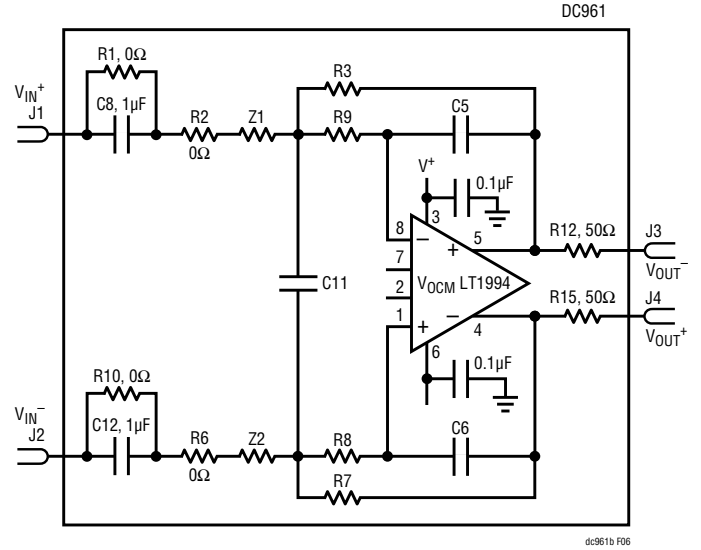

Figure 6. A DC961 Configured as a Second Order Lowpass Filter

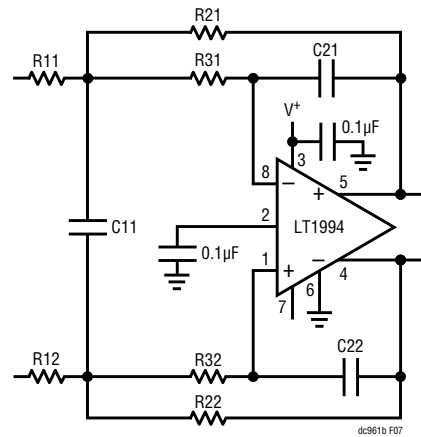

Figure 7. Fully Differential, 2nd Order, Lowpass Filter Design Schematic

## QUICK TEST PROCEDURE

### Design Procedure

The following procedure is from the LT1994 data sheet. The design schematic resistor and capacitor designators have the following correspondence with the DC961 resistor and capacitor designators:

Design Schematic	DC961
R11	Z1
R21	R3
R31	R9
C11	C11
C21	C5
C22	C6
R12	Z2
R22	R7
R32	R8

### Differential 2nd Order Butterworth Lowpass Filter

$$f_{3dB} \leq 2.5\text{MHz and Gain} \leq 8.8 \text{ or Gain} \leq \frac{2.5\text{MHz}}{f_{3dB}}$$

Component Calculation:

R11 = R12, R21 = R22, R31 = R32, C21 = C22, C11 = 10 • C21, R1 = R11, R2 = R21, R3 = R31, C2 = C21 and C1 = C11

1. Calculate an absolute value for C2 (C2<sub>abs</sub>) using a specified -3dB frequency

$$C2_{abs} = \frac{4 \cdot 10^5}{f_{3dB}} \text{ (C2}_{abs} \text{ IN pF AND } f_{3dB} \text{ IN kHz)}$$

2. Select a standard 5% capacitor value nearest the absolute value for C2 (C1 = 10 • C2)
3. Calculate R3, R2 and R1 using the standard 5% C2 value, the specified f<sub>3dB</sub> and the specified passband gain (G<sub>N</sub>):

R1, R2 and R3 equations (C2 in pF and f<sub>3dB</sub> in kHz)

$$R3 = \frac{(1.121 - \sqrt{(1.131 - 0.127 \cdot G_N)}) \cdot 10^8}{(G_N + 1) \cdot C2 \cdot f_{3dB}}$$

$$R2 = \frac{1.266 \cdot 10^{15}}{R3 \cdot C2^2 \cdot f_{3dB}^2} \quad R1 = \frac{R2}{G_N}$$

# DEMO MANUAL DC961B

---

## DEMONSTRATION BOARD IMPORTANT NOTICE

Linear Technology Corporation (LTC) provides the enclosed product(s) under the following **AS IS** conditions:

This demonstration board (DEMO BOARD) kit being sold or provided by Linear Technology is intended for use for **ENGINEERING DEVELOPMENT OR EVALUATION PURPOSES ONLY** and is not provided by LTC for commercial use. As such, the DEMO BOARD herein may not be complete in terms of required design-, marketing-, and/or manufacturing-related protective considerations, including but not limited to product safety measures typically found in finished commercial goods. As a prototype, this product does not fall within the scope of the European Union directive on electromagnetic compatibility and therefore may or may not meet the technical requirements of the directive, or other regulations.

If this evaluation kit does not meet the specifications recited in the DEMO BOARD manual the kit may be returned within 30 days from the date of delivery for a full refund. **THE FOREGOING WARRANTY IS THE EXCLUSIVE WARRANTY MADE BY THE SELLER TO BUYER AND IS IN LIEU OF ALL OTHER WARRANTIES, EXPRESSED, IMPLIED, OR STATUTORY, INCLUDING ANY WARRANTY OF MERCHANTABILITY OR FITNESS FOR ANY PARTICULAR PURPOSE. EXCEPT TO THE EXTENT OF THIS INDEMNITY, NEITHER PARTY SHALL BE LIABLE TO THE OTHER FOR ANY INDIRECT, SPECIAL, INCIDENTAL, OR CONSEQUENTIAL DAMAGES.**

The user assumes all responsibility and liability for proper and safe handling of the goods. Further, the user releases LTC from all claims arising from the handling or use of the goods. Due to the open construction of the product, it is the user's responsibility to take any and all appropriate precautions with regard to electrostatic discharge. Also be aware that the products herein may not be regulatory compliant or agency certified (FCC, UL, CE, etc.).

No License is granted under any patent right or other intellectual property whatsoever. **LTC assumes no liability for applications assistance, customer product design, software performance, or infringement of patents or any other intellectual property rights of any kind.**

LTC currently services a variety of customers for products around the world, and therefore this transaction **is not exclusive**.

**Please read the DEMO BOARD manual prior to handling the product.** Persons handling this product must have electronics training and observe good laboratory practice standards. **Common sense is encouraged.**

This notice contains important safety information about temperatures and voltages. For further safety concerns, please contact a LTC application engineer.

Mailing Address:

Linear Technology  
1630 McCarthy Blvd.  
Milpitas, CA 95035

Copyright © 2004, Linear Technology Corporation

## Данный компонент на территории Российской Федерации

### Вы можете приобрести в компании MosChip.

Для оперативного оформления запроса Вам необходимо перейти по данной ссылке:

<http://moschip.ru/get-element>

Вы можете разместить у нас заказ для любого Вашего проекта, будь то серийное производство или разработка единичного прибора.

В нашем ассортименте представлены ведущие мировые производители активных и пассивных электронных компонентов.

Нашей специализацией является поставка электронной компонентной базы двойного назначения, продукции таких производителей как XILINX, Intel (ex.ALTERA), Vicor, Microchip, Texas Instruments, Analog Devices, Mini-Circuits, Amphenol, Glenair.

Сотрудничество с глобальными дистрибьюторами электронных компонентов, предоставляет возможность заказывать и получать с международных складов практически любой перечень компонентов в оптимальные для Вас сроки.

На всех этапах разработки и производства наши партнеры могут получить квалифицированную поддержку опытных инженеров.

Система менеджмента качества компании отвечает требованиям в соответствии с ГОСТ Р ИСО 9001, ГОСТ РВ 0015-002 и ЭС РД 009

### Офис по работе с юридическими лицами:

105318, г.Москва, ул.Щербаковская д.3, офис 1107, 1118, ДЦ «Щербаковский»

Телефон: +7 495 668-12-70 (многоканальный)

Факс: +7 495 668-12-70 (доб.304)

E-mail: [info@moschip.ru](mailto:info@moschip.ru)

Skype отдела продаж:

moschip.ru

moschip.ru\_4

moschip.ru\_6

moschip.ru\_9