

## DESCRIPTION

The MP4690 is a MOSFET based smart bypass for LED open protection, which provides a current bypass in the case of a single LED fails and becomes an open circuit. When the LED heals itself or is replaced, the MP4690 automatically resets. This device features very low voltage drop so that the conduction loss is very small during the protection. It achieves excellent thermal performance and energy efficiency.

LED lighting requires high reliability, especially in applications, such as automobiles, aircrafts, and streetlights. The MP4690 is used in parallel with each LED so that when one LED fails, other LEDs in the same string can still function normally.

The usage of the MP4690 is not limited to just LED loads. It can also be used with other loads where open protection is required.

The MP4690 is typically used with 1W-2W LEDs. The device is available in a SOD123 package.

## FEATURES

- Simple Two Terminal Device
- Automatic Reset if the LED Heals itself or is Replaced
- 0.22Ω Typical On-state Resistance
- Less than 1μA Off-state Current
- Available in SOD123 Package

## APPLICATIONS

- LEDs where Preventive Maintenance is not Practical
- LED Headlights
- LEDs with high Reliability Requirements
- Crowbar Protection for Open Circuit Conditions
- Over-voltage Protection for Sensitive Circuits

For MPS green status, please visit MPS website under Quality Assurance. "MPS" and "The Future of Analog IC Technology" are Registered Trademarks of Monolithic Power Systems, Inc.

## TYPICAL APPLICATION

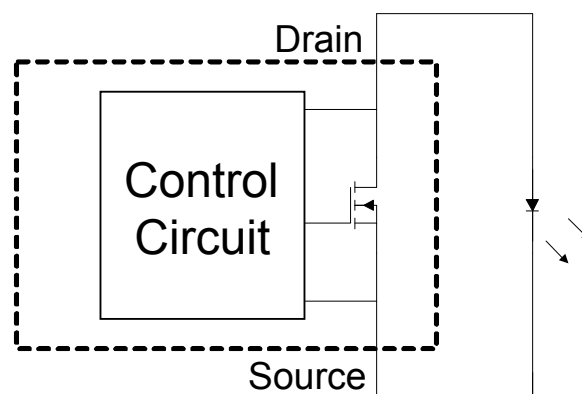

### ORDERING INFORMATION

Part Number*	Package	Top Marking	Free Air Temperature (T <sub>A</sub> )
MP4690GSD	SOD123	AAY	-40°C to +105°C

\* For Tape & Reel, add suffix -Z (e.g. MP4690GSD-Z)  
 For RoHS Compliant Packaging, add suffix -LF (e.g. MP4690GSD-LF-Z)

### PACKAGE REFERENCE

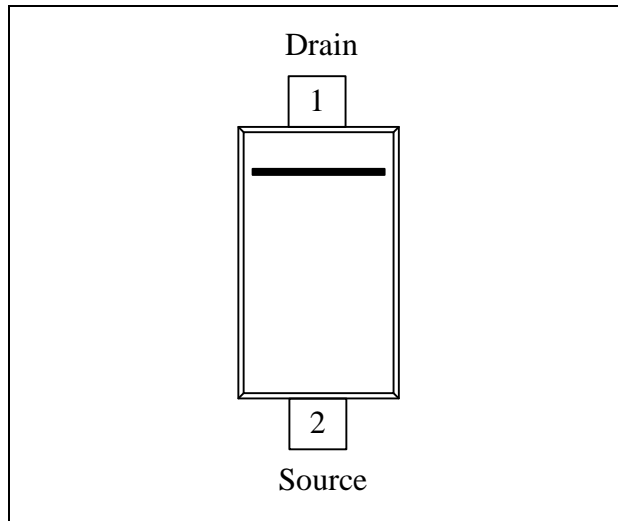

#### ABSOLUTE MAXIMUM RATINGS <sup>(1)</sup>

Drain to Source Voltage.....	-0.3V to +7.5V
Continuous Power Dissipation (T <sub>A</sub> =+25°C) <sup>(2)</sup>	0.37W
Junction Temperature .....	150°C
Lead Temperature .....	260°C
Storage Temperature.....	-65°C to +150°C

#### Recommended Operating Conditions <sup>(3)</sup>

Maximum On-state Current.....	0.7A
Maximum Junction Temp. (T <sub>J</sub> ) .....	+125°C

Thermal Resistance <sup>(4)</sup>	$\theta_{JA}$	$\theta_{JC}$
SOD123 .....	340	150 .. °C/W

#### Notes:

- 1) Exceeding these ratings may damage the device.
- 2) The maximum allowable power dissipation is a function of the maximum junction temperature T<sub>J</sub>(MAX), the junction-to-ambient thermal resistance  $\theta_{JA}$ , and the ambient temperature T<sub>A</sub>. The maximum allowable continuous power dissipation at any ambient temperature is calculated by P<sub>D</sub>(MAX)=(T<sub>J</sub>(MAX)-T<sub>A</sub>)/  $\theta_{JA}$ . Exceeding the maximum allowable power dissipation will cause excessive die temperature, and the regulator will go into thermal shutdown. Internal thermal shutdown circuitry protects the device from permanent damage.
- 3) The device is not guaranteed to function outside of its operating conditions.
- 4) Measured on JESD51-7, 4-layer PCB.

## ELECTRICAL CHARACTERISTICS

$T_A = +25^\circ\text{C}$ , unless otherwise noted.

Specifications over temperature are guaranteed by design and characterization.

Parameter	Symbol	Condition	Min	Typ	Max	Units
Off-state Current	$I_{LEAK}$	$V_{DS} = 3.5\text{V}$		1		$\mu\text{A}$
Protection Clamp Voltage	$V_{CL}$	$I_{CL} = 350\text{mA}$		7		V
Protection Threshold	$V_{THP}$			6		V
On Resistance <sup>(5)</sup>	$R_{DS(ON)}$	$I_{DS} = 350\text{mA}$		0.22		$\Omega$
Protection Delay	$T_D$	$I_{DS} = 350\text{mA}$		120		ns
Hiccup frequency	$F_H$	$I_{DS} = 350\text{mA}$		25		kHz
ESD Withstand Voltage <sup>(5)</sup>	$V_{ESD}$	HBM		$\pm 8$		kV

Note:

5) Guaranteed by design.

## PIN FUNCTIONS

Pin #	Name	Description
1	Drain	Drain of the MOSFET. Connect it to anode of LED.
2	Source	Source of the MOSFET, Connect it to cathode of LED.

## TYPICAL PERFORMANCE CHARACTERISTICS

$I_{LED}=700mA$ ,  $T_A=+25^{\circ}C$ , unless otherwise noted.

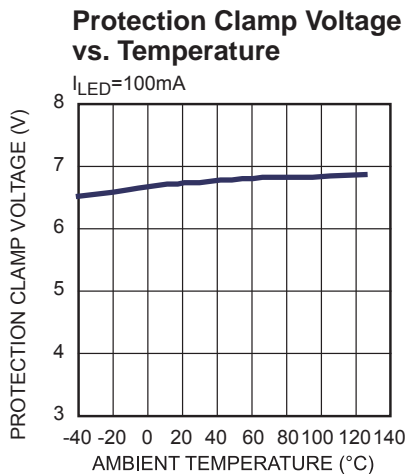
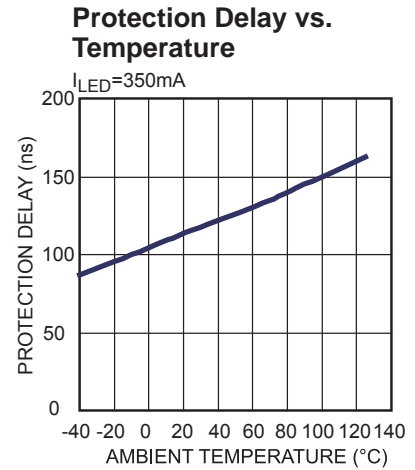
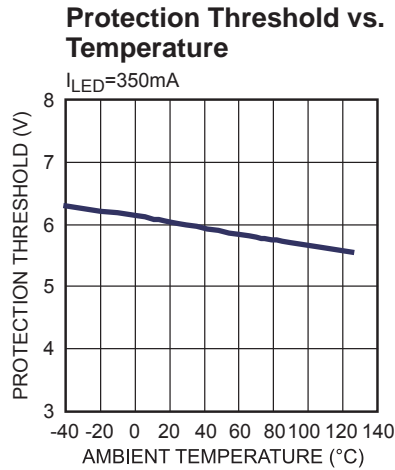
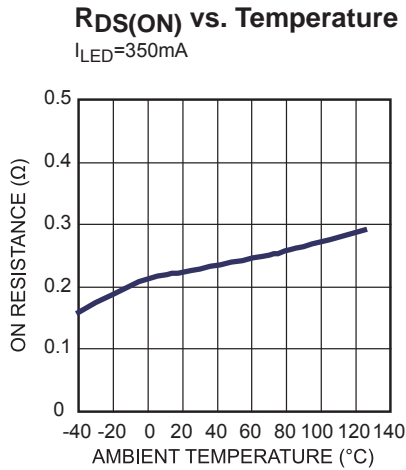
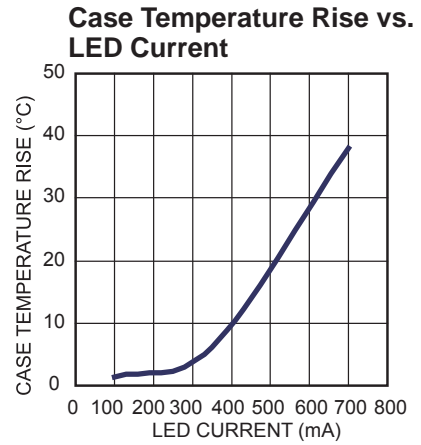
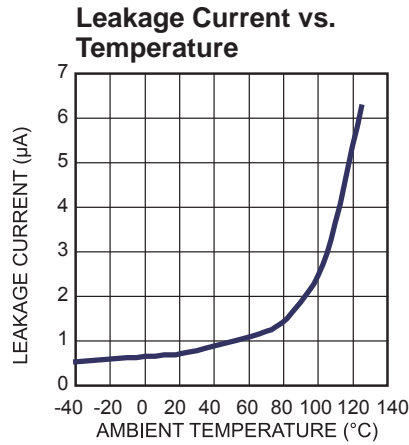
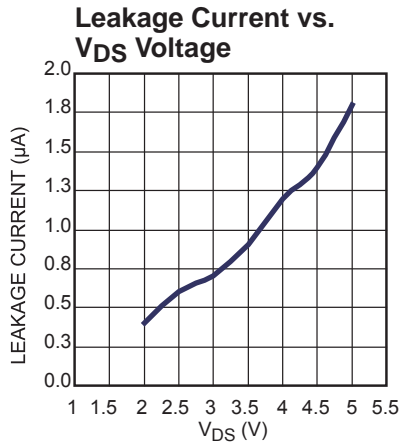

## TYPICAL PERFORMANCE CHARACTERISTICS *(continued)*

$I_{LED}=700mA$ ,  $T_A=+25^{\circ}C$ , unless otherwise noted.

Steady State of No LED Open

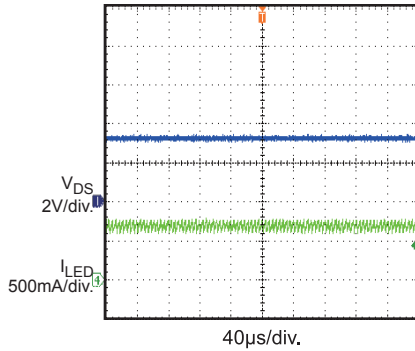

Steady State of LED Open Circuit

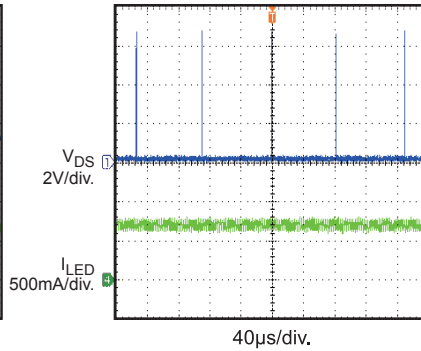

Zoom In Steady State Waveform

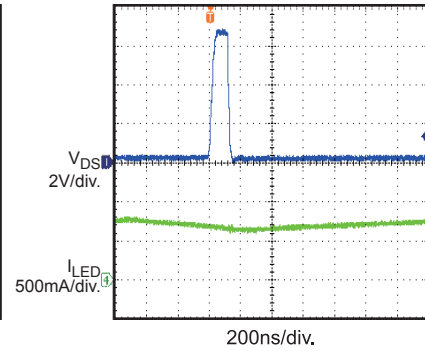

Open Protection Entry

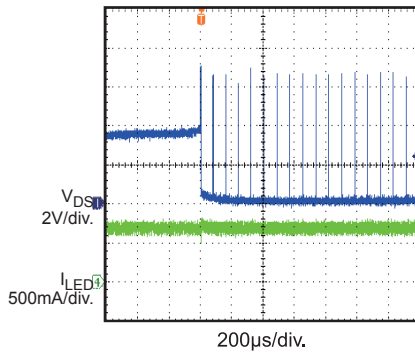

Protection Exit when LED Heals

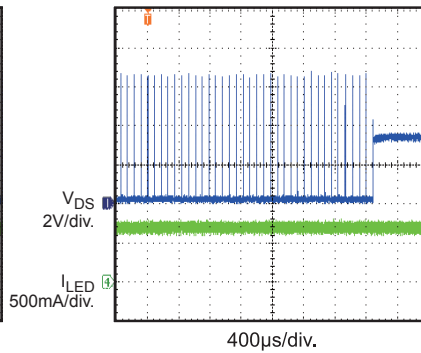

PWM Dimming at Small Duty Cycle with one LED Open  
 $F_s=1kHz$ ,  $D=10\%$

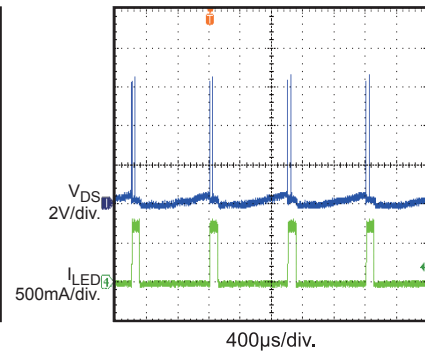

PWM Dimming at Large Duty Cycle with one LED Open  
 $F_s=1kHz$ ,  $D=90\%$

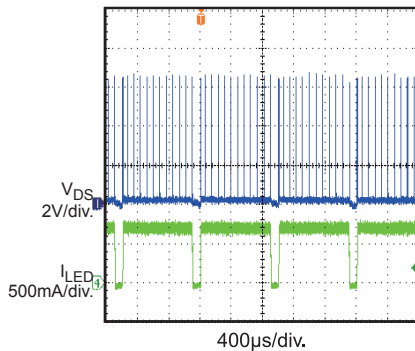

## BLOCK DIAGRAM

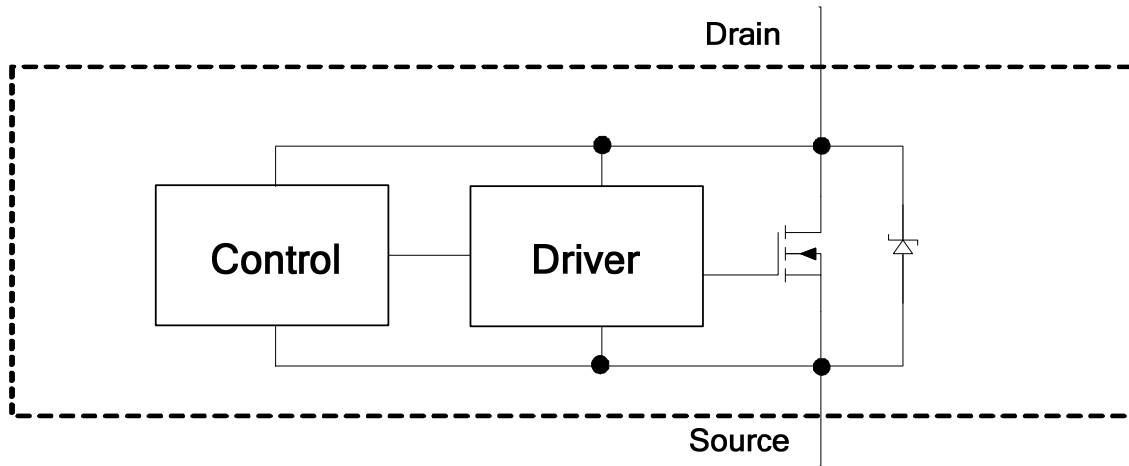

Functional Block Diagram

## OPERATION

The MP4690 monitors the drain to source voltage of its internal MOSFET. When the  $V_{DS}$  is higher than the threshold voltage of 6V, the MOSFET is turned on to provide a current path to replace the opened LED.

After the MOSFET is turned on, the MP4690 checks the LED status every 40us~100us. If the LED is healed, the MP4690 exits the protection and gives the current path back to the LED. If the

LED is still open, the MP4690 continues its protection. The current goes through the internal MOSFET of the MP4690.

The status-check duration can be as short as 120ns. During the 120ns, the LED current of string is maintained through the zener diode inside the MP4690. The voltage across the MP4690 is clamped to 7V.

### APPLICATION INFORMATION

Open LED protection serves as an electronic shunt to provide a current bypass for a single LED that fails due to an open circuit. A typical forward voltage drop of a normally on-state LED is approximately 3V, which is below the MP4690 turn-on threshold. When an LED is open, the voltage across the opened LED is boosted up by LED controller, causing the protection device to turn on.

The MP4690 integrates a low 220mΩ on-resistance N-channel MOSFET to reduce the turn-on power loss. This feature makes the MP4690 suitable for one-, two-, or three-watt LEDs that have a nominal 3V forward voltage drop.

The MP4690 is a two terminal device, which automatically resets if the LED heals itself or is replaced.

#### Applying the Open LED Protection

The protection applies to any designs and it is easy to implement. By connecting one MP4690 in parallel with each LED in a string, the string is protected from an open-circuit failure.

Figure 1 shows a typical LED driver circuit with open LED protection device, MP4690.

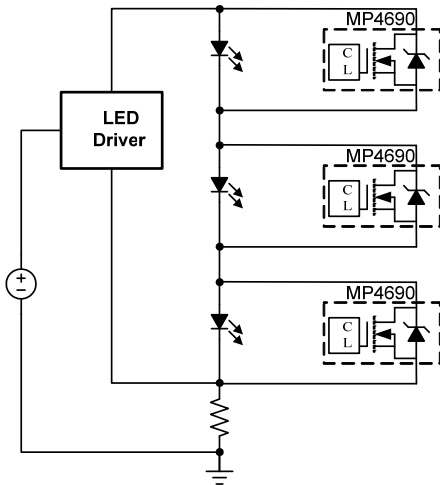

Figure 1. LED Open Protection Circuit

The LED driver can be any kind of topology that can provide constant current output, such as Buck, Boost or Buck-Boost converter.

#### Adding an Inductor to Smooth LED Current

There are many kinds of LED driver circuits. Some require output capacitors while others do not. When the MP4688 LED driver is used, there is no need to add an external inductor.

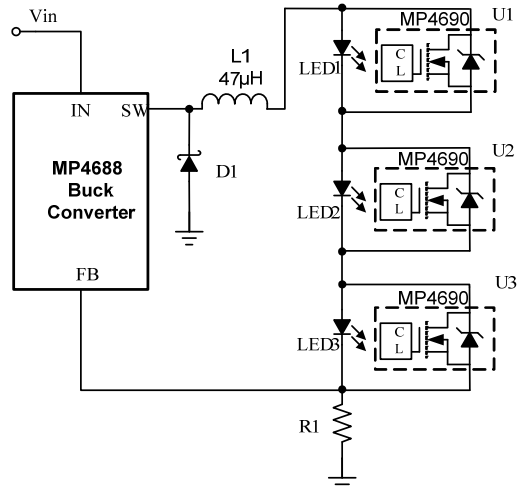
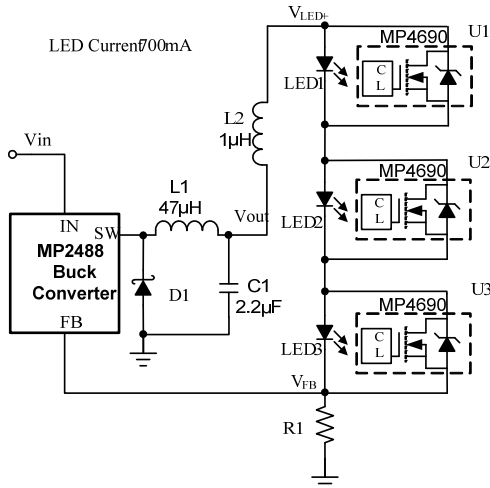

Figure 2 No Output Capacitor LED Driver

As shown in Figure 2, since there is no output capacitor, the LED string is connected to the buck output inductor L1 directly. In case an open circuit happens at LED1, for example, the inductor L1 still maintains the LED current. At the same time, the voltage across the open circuit LED1 is boosted up immediately. U1 clamps the voltage at 7V. After about 120ns delay, the internal MOSFET of U1 turns on, thus the bypass circuit is established. During the 120ns period, the current flow in LED2, LED3 is nearly unchanged. That's a benefit of the output inductor L1, which acts like a current source.

For LED drivers that require output capacitors, maybe an additional inductor with small value is needed for short LED strings (<5 LEDs). Otherwise, the LED current will drop to zero rapidly when any LED open circuit happens and the MP4690 doesn't have enough time to turn on the switch. Figure 3 is an example of an LED driver circuit with an output capacitor.



**Figure 3 LED Driver with Output Capacitor**

For most current mode PWM control Buck converters like MP2488, the output capacitor C1 is necessary to reduce the output voltage ripple and stabilize the control loop. Without the external inductor L2, two things happen when LED1 enters open circuit. Firstly, the voltage of C1 can't change rapidly so U1 can't turn on until  $V_{OUT}$  is 6V higher than before. There is no current path to maintain the LED2, LED3 current constant so the LED current collapses to zero rapidly and it's discontinuous. Secondly, the  $V_{out}$  voltage has large voltage ripple. As a result, the primary LED driver controller can't work at stable state unless remove the  $V_{out}$  ripple voltage.

The added inductor L2 can avoid above two issues without influencing the original LED driver circuit's normal operation. The L2 acts like a current source to boost up the U1 drain voltage for hiccup operation. When the U1 switch is off, LED current drops but the inductor will try to push the current into the LED string, hence charge up the MP4690 drain voltage and initiates next hiccup cycle within 120ns. The inductor L2 also eliminates the voltage ripple of  $V_{OUT}$ .

A larger value inductor results in less LED current drop during which the MP4690 switch is off, keeping the LED current more constant. However, a larger value inductor has a larger physical size, higher series resistance, and lower saturation current.

A 1µH inductor is recommended for 2W LED applications and a 2.2µH inductor is recommended for most 1W LED applications. However, a more exact inductance value can be calculated. A good rule of thumb is to allow the LED current drop to zero at the moment the MP4690 switch turns on.

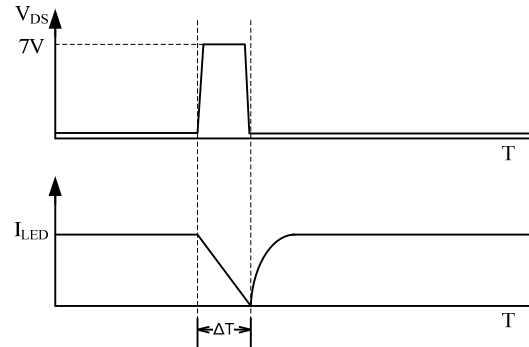

**Figure 4 External Inductor Calculation**

As figure 4 shows, the external inductor value can be calculated by following equation:

$$L = \frac{7V \times \Delta T}{I_{LED}}$$

Where  $V_{DS}$  is the voltage of MP4690,  $I_{LED}$  is the LED output current and  $\Delta T$  is the MP4690 protection delay time, typical value is about 100~150ns.

If the LED string is long enough, the inductor can probably be saved even there exists output capacitor. The LED forward voltage change will make up the voltage change to initiate MP4690 hiccup mode. Generally speaking, for 1W LED application when the series LED quantity is more than 5, the external inductor can be saved.

**Optional Decoupling Capacitor and PCB Layout**

An optional ceramic decoupling capacitor across MP4690 is recommended for large size LED application. The decoupling capacitor can reduce the voltage spike which is produced by the parasitic inductance and high di/dt from the open circuit LED. A 3.3nF ceramic capacitor is recommended for most applications where the PCB trace from MP4690 to protected LED is too long. In order to remove the decoupling capacitor, we recommended improved the PCB layout as following figure shows.



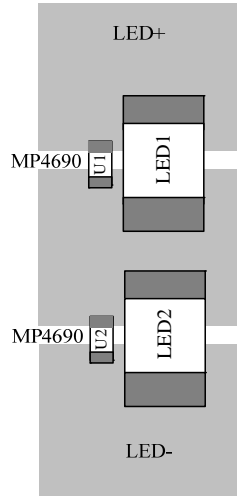
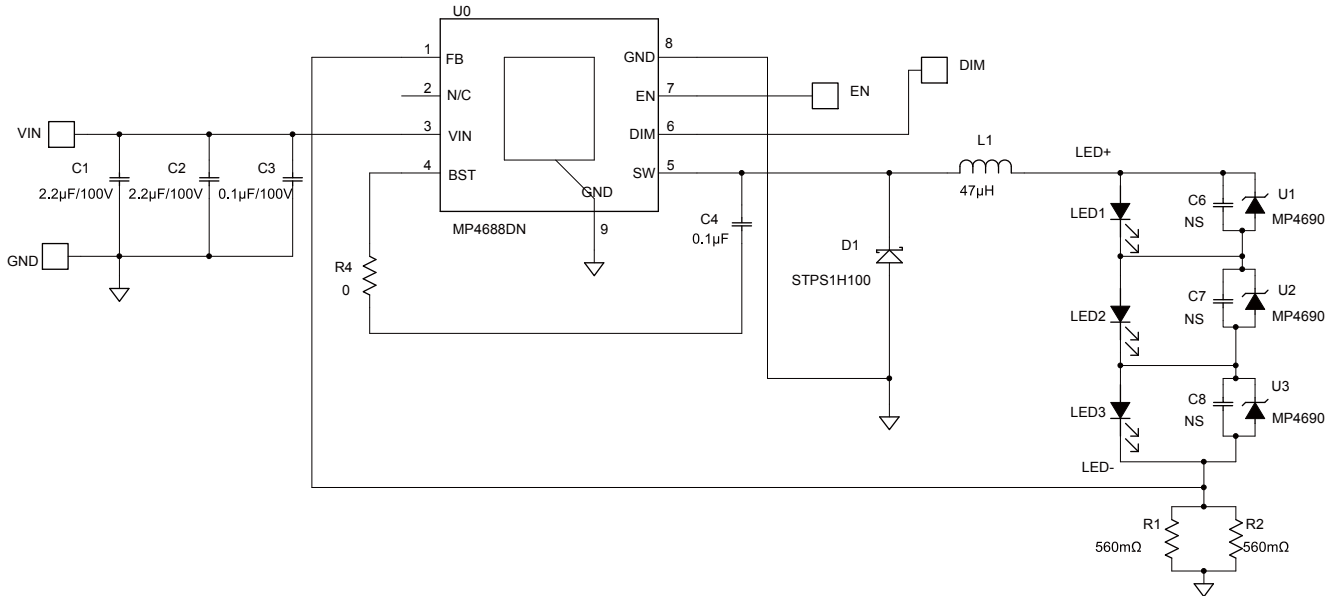
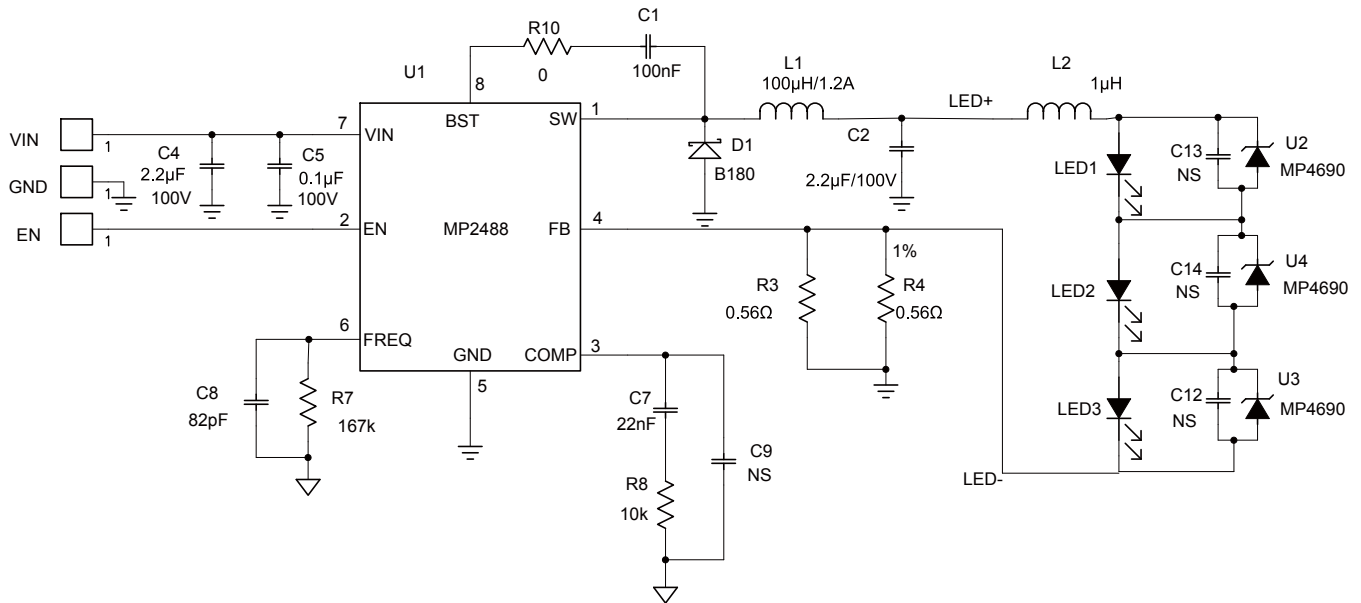

**Figure 5 PCB Layout**

The high current path (LED1 Anode, U1 Drain, U1 Source, LED1 Cathode) should be placed very close to the device with short, direct and wide trace. U1 should be placed as close as possible to the protected LED.

### LED Dimming

MP4690 also work well with various brightness control methods for LEDs. The brightness of LEDs is best controlled by pulse width modulation (PWM) with the switching frequency typically between 100Hz and 1kHz. Dimming via DC current can cause unwanted color shifts. Either way, MP4690 will not interfere with the dimming strategy employed.

**TYPICAL APPLICATION CIRCUITS**

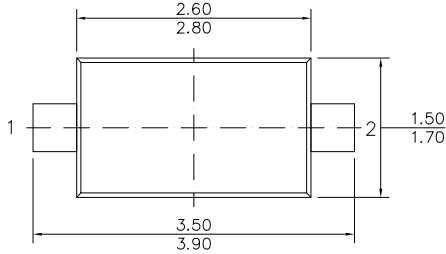
**Figure 6 MP4688 Based Application – Without Output Capacitor**

**Figure 7 MP2488 Based Application – With Output Capacitor**

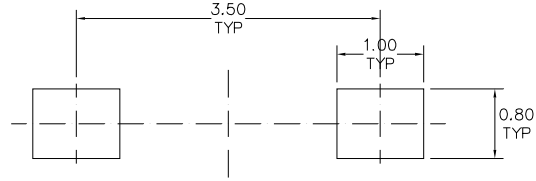
**PACKAGE INFORMATION**
**SOD123**

*TOP VIEW*

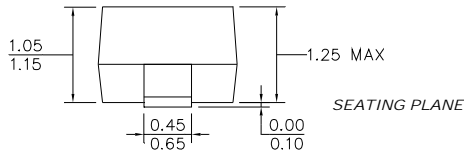

*RECOMMENDED LAND PATTERN*



*FRONT VIEW*

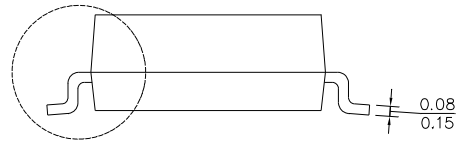

*SIDE VIEW*

***NOTE:***

- 1) ALL DIMENSIONS ARE IN MILLIMETERS.
- 2) PACKAGE LENGTH DOES NOT INCLUDE MOLD FLASH, PROTRUSION OR GATE BURR.
- 3) PACKAGE WIDTH DOES NOT INCLUDE INTERLEAD FLASH OR PROTRUSION.
- 4) LEAD COPLANARITY (BOTTOM OF LEADS AFTER FORMING) SHALL BE 0.10 MILLIMETERS MAX.
- 5) DRAWING CONFORMS TO JEDEC DO-219.
- 6) DRAWING IS NOT TO SCALE.

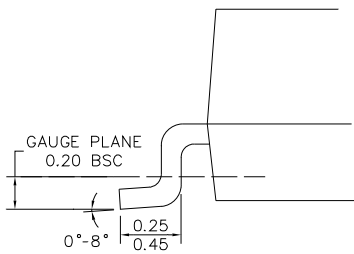

*DETAIL "A"*

**NOTICE:** The information in this document is subject to change without notice. Users should warrant and guarantee that third party Intellectual Property rights are not infringed upon when integrating MPS products into any application. MPS will not assume any legal responsibility for any said applications.

## Данный компонент на территории Российской Федерации

### Вы можете приобрести в компании MosChip.

Для оперативного оформления запроса Вам необходимо перейти по данной ссылке:

<http://moschip.ru/get-element>

Вы можете разместить у нас заказ для любого Вашего проекта, будь то серийное производство или разработка единичного прибора.

В нашем ассортименте представлены ведущие мировые производители активных и пассивных электронных компонентов.

Нашей специализацией является поставка электронной компонентной базы двойного назначения, продукции таких производителей как XILINX, Intel (ex.ALTERA), Vicor, Microchip, Texas Instruments, Analog Devices, Mini-Circuits, Amphenol, Glenair.

Сотрудничество с глобальными дистрибьюторами электронных компонентов, предоставляет возможность заказывать и получать с международных складов практически любой перечень компонентов в оптимальные для Вас сроки.

На всех этапах разработки и производства наши партнеры могут получить квалифицированную поддержку опытных инженеров.

Система менеджмента качества компании отвечает требованиям в соответствии с ГОСТ Р ИСО 9001, ГОСТ РВ 0015-002 и ЭС РД 009

### Офис по работе с юридическими лицами:

105318, г.Москва, ул.Щербаковская д.3, офис 1107, 1118, ДЦ «Щербаковский»

Телефон: +7 495 668-12-70 (многоканальный)

Факс: +7 495 668-12-70 (доб.304)

E-mail: [info@moschip.ru](mailto:info@moschip.ru)

Skype отдела продаж:

moschip.ru

moschip.ru\_4

moschip.ru\_6

moschip.ru\_9