

**General Description**

The MAX3736 evaluation kit (EV kit) is an assembled demonstration board that provides complete optical evaluation of the MAX3736 3.3V multirate laser driver.

The EV kit is composed of an optical test circuit. The output of the optical evaluation section is configured for attachment to a laser/monitor diode that is configured in the standard four-lead laser connection on BOSA packages.

**Features**

- Single +3.3V Power-Supply Operation
- AC-Coupling Provided On-Board
- Allows Optical Evaluation
- Proven PCB Layout
- Fully Assembled and Tested

Ordering Information appears at end of data sheet.

**Optical Evaluation Component List**

| DESIGNATION            | QTY | DESCRIPTION                               |
|------------------------|-----|---|
| C1, C11, C15, C16, C20 | 5   | 0.1µF ±10% ceramic capacitors (0402)      |
| C2–C4                  | 0   | Not installed, ceramic capacitors (0402)  |
| C5, C6                 | 2   | 220pF ±10% ceramic capacitors (0402)*     |
| C7                     | 1   | 1µF ±10% ceramic capacitor (0805)         |
| C17, C23               | 2   | 0.01µF ±5% ceramic capacitors (0402)      |
| D1                     | 0   | Not installed, user-supplied laser        |
| J1, J2                 | 2   | SMA connectors, tab contact               |
| J8, J10, TP1–TP10      | 12  | Test points                               |
| JU1, JU2, JU13         | 3   | 2-pin headers, 0.1in centers              |
| L1, L3                 | 2   | Ferrite beads (0402)<br>Murata BLM15HG102 |

| DESIGNATION | QTY | DESCRIPTION  |
|-------------|-----|--|
| R1, R2      | 2   | 1.5kΩ ±5% resistors (0402)                                     |
| R3          | 1   | 75Ω ±5% resistor (0402)*                                       |
| R4, R18     | 2   | 1.0kΩ ±1% resistors (0402)                                     |
| R15, R17    | 2   | 20kΩ variable resistors  |
| R21         | 1   | 10Ω ±5% resistor (0402)  |
| R22         | 1   | 24Ω ±5% resistor (0402)*                                       |
| R23         | 1   | 15Ω ±5% resistor (0402)  |
| U2          | 1   | 3.3V multirate laser driver (16 TQFN-EP*)<br>Maxim MAX3736ETE+ |
| —           | 3   | Shunts   |
| —           | 1   | PCB: MAX3736 EVALUATION KIT REV C                              |

\*EP = Exposed pad.

*\*These components are part of the compensation network, which can reduce overshoot and ringing. Ringing due to parasitic series inductance of the laser can be eliminated with R22/R3 and C6/C5. Starting values for most coaxial lasers is R3 = 75Ω in series with C5 = 220pF and R22 = 24Ω in series with C6 = 220pF. These values should be experimentally adjusted until the optical eye diagram is optimized.*

**Component Supplier**

| SUPPLIER                               | PHONE        | WEBSITE                     |
|--|--------------|-----------------------------|
| Murata Electronics North America, Inc. | 770-436-1300 | www.murata-northamerica.com |

**Note:** Indicate that you are using the MAX3736 when contacting this component supplier.



**QuickStart**

**Procedure**

For optical evaluation of the device, configure the EV kit as follows:

- 1) To enable the outputs, connect DIS to GND by placing a shunt across jumper JU13.
- 2) The EV kit is designed to allow connection to a typical BOSA-packaged laser. Connect the laser with monitor diode (Figure 1) as follows:  
 Keeping its leads as short as possible, connect the laser diode to the appropriate pads in the cut-out portion on the top (component) side of the PCB.  
**Note:** When performing the following resistance checks, manually set the ohmmeter to a high range to avoid forward biasing the on-chip ESD protection diodes.
- 3) Adjust R17, the R<sub>MODSET</sub> potentiometer, for maximum resistance (≈20kΩ) between TP7 and ground. This sets the modulation current to a low value (< 10mA). Refer to the *Design Procedure* section in the MAX3736 IC data sheet.
- 4) Apply a differential input signal (200mV<sub>P-P</sub> to 2400mV<sub>P-P</sub>) between SMA connectors J1 and J2 (IN+ and IN-).
- 5) Attach the laser diode fiber connector to an optical-to-electrical converter.

- 6) Connect a 3.3V supply between J8 (V<sub>CC</sub>) and J10 (GND). Set the current limit to 200mA and power on the device.
- 7) Adjust R15 (R<sub>BIASSET</sub>) until the desired average optical power is achieved.
- 8) The BIAS current can be monitored at TP8 (V<sub>BC\_MON</sub>) using the following equation:

$$I_{BIAS} = \frac{V_{BC\_MON}}{1000\Omega} \times 85$$

**Note:** If the voltage at TP8 exceeds 1.39V, the BC\_MON pin goes out of regulation.

- 9) Adjust R17 (R<sub>MODSET</sub>) until the desired optical amplitude is achieved. Optical amplitude can be observed on an oscilloscope connected to an optical-to-electrical converter. Laser overshoot and ringing can be improved by appropriate selection of R3, R21–R23, C5, and C6, as described in the *Design Procedure* section in the MAX3736 IC data sheet.  
**Note:** External DACs can be used to control the bias and modulation current. To do this, remove shunts from jumpers JU1 and JU2 to disconnect potentiometers R15 (R<sub>BIASSET</sub>) and R17 (R<sub>MODSET</sub>). Connect the DAC outputs to TP6 (BIASSET) and TP7 (MODSET).

**Table 1. Adjustment and Control Descriptions (see the Quick Start section first)**

| DESIGNATION | NAME                 | DESCRIPTION   |
|-------------|----------------------|---|
| JU13        | DIS                  | Enables/disables the output currents. Active low (shunt across JU13 to enable output currents).   |
| R15         | R <sub>BIASSET</sub> | Adjusts the bias current.   |
| R17         | R <sub>MODSET</sub>  | Adjusts the laser modulation current.   |
| TP8         | BC_MON               | TP8 offers a connection to probe the BC_MON current through a 1kΩ resistor to ground. This allows the bias current to be determined as I <sub>BIAS</sub> = V <sub>BC_MON</sub> /1000Ω x 85. |
| TP9         | BIAS                 | TP9 allows the voltage at the BIAS pin to be monitored.   |
| TP10        | MD                   | TP10 offers a connection to probe the monitor diode current through a 1kΩ resistor to ground. The current can be determined as I <sub>MD</sub> = V <sub>MD</sub> /1000Ω.                    |

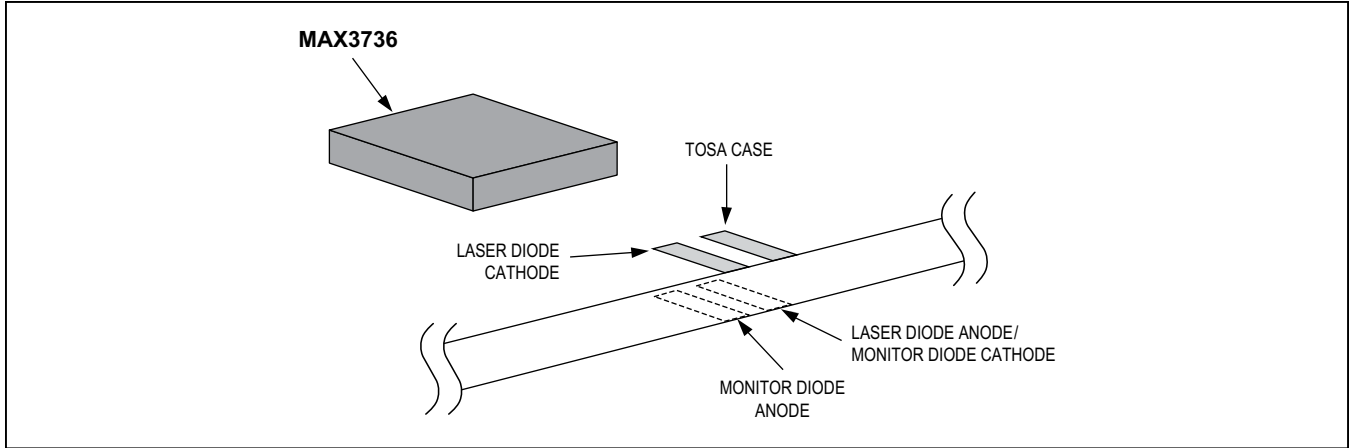

Figure 1. Attachment of Packaged Laser to the MAX3736 EV Kit

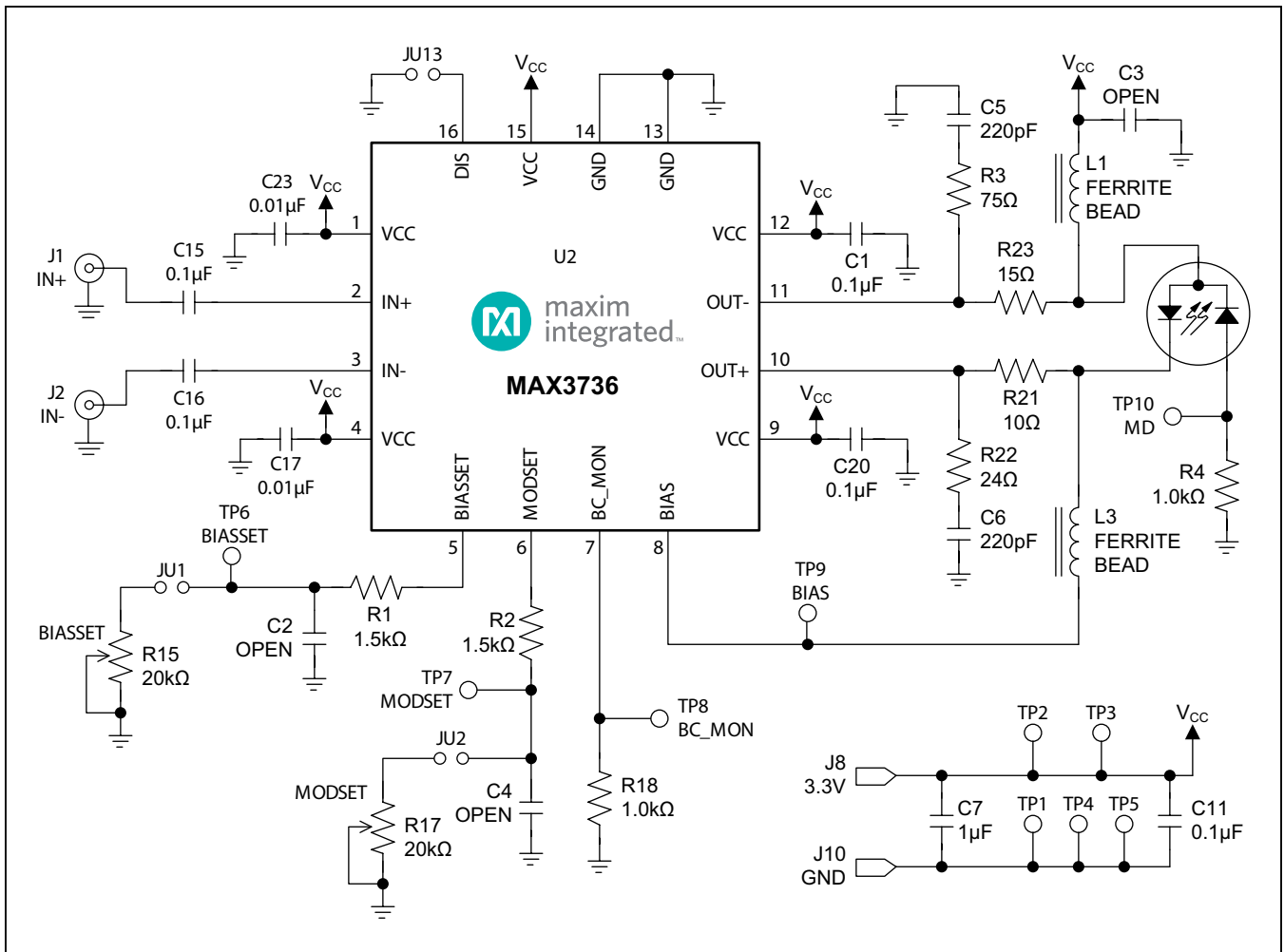

Figure 2. MAX3736 EV Kit Schematic

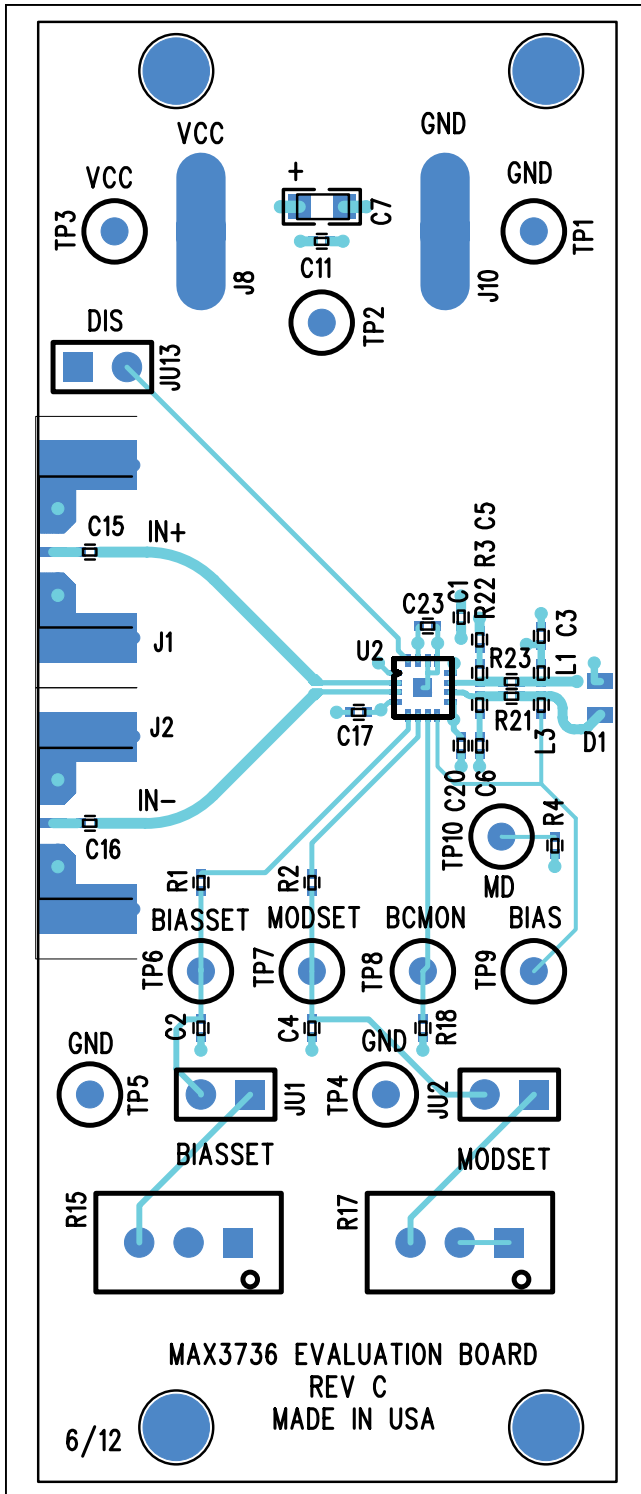

Figure 3. MAX3736 EV Kit Component Placement Guide—Component Side

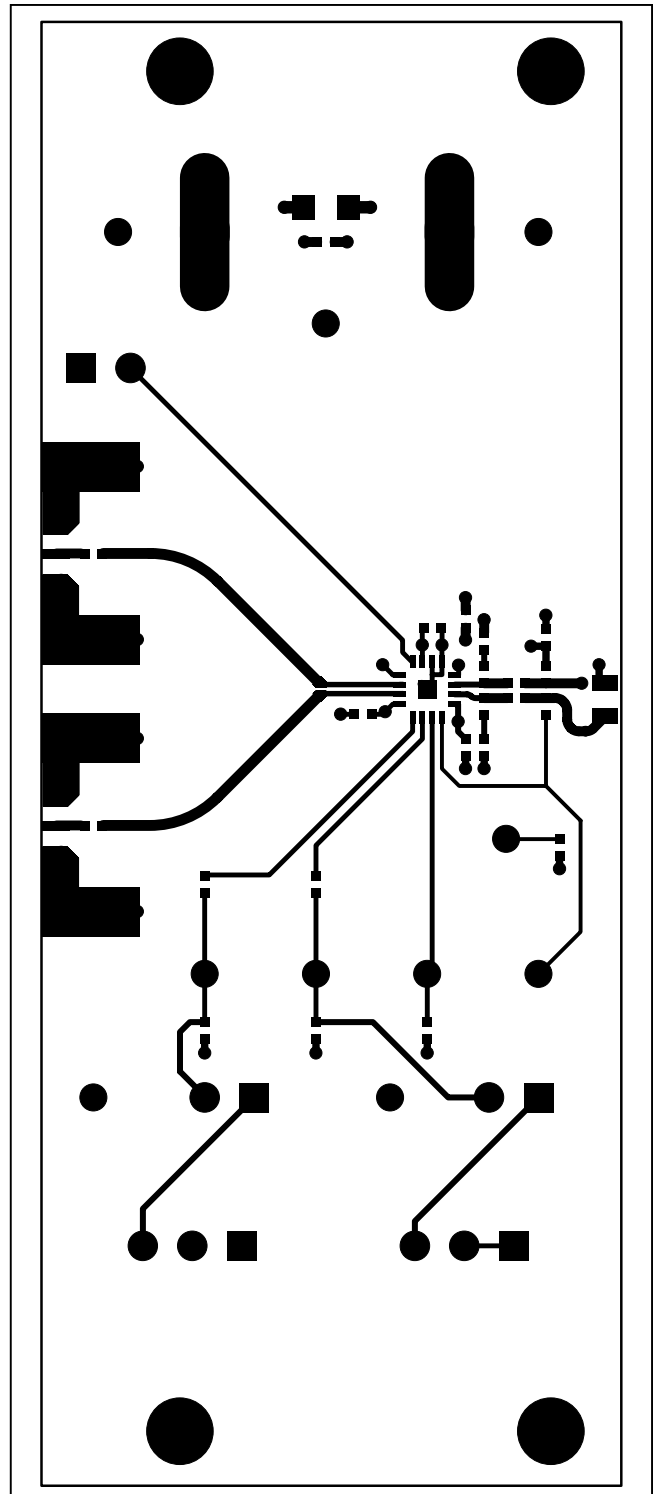

Figure 4. MAX3736 EV Kit PCB Layout—Component Side

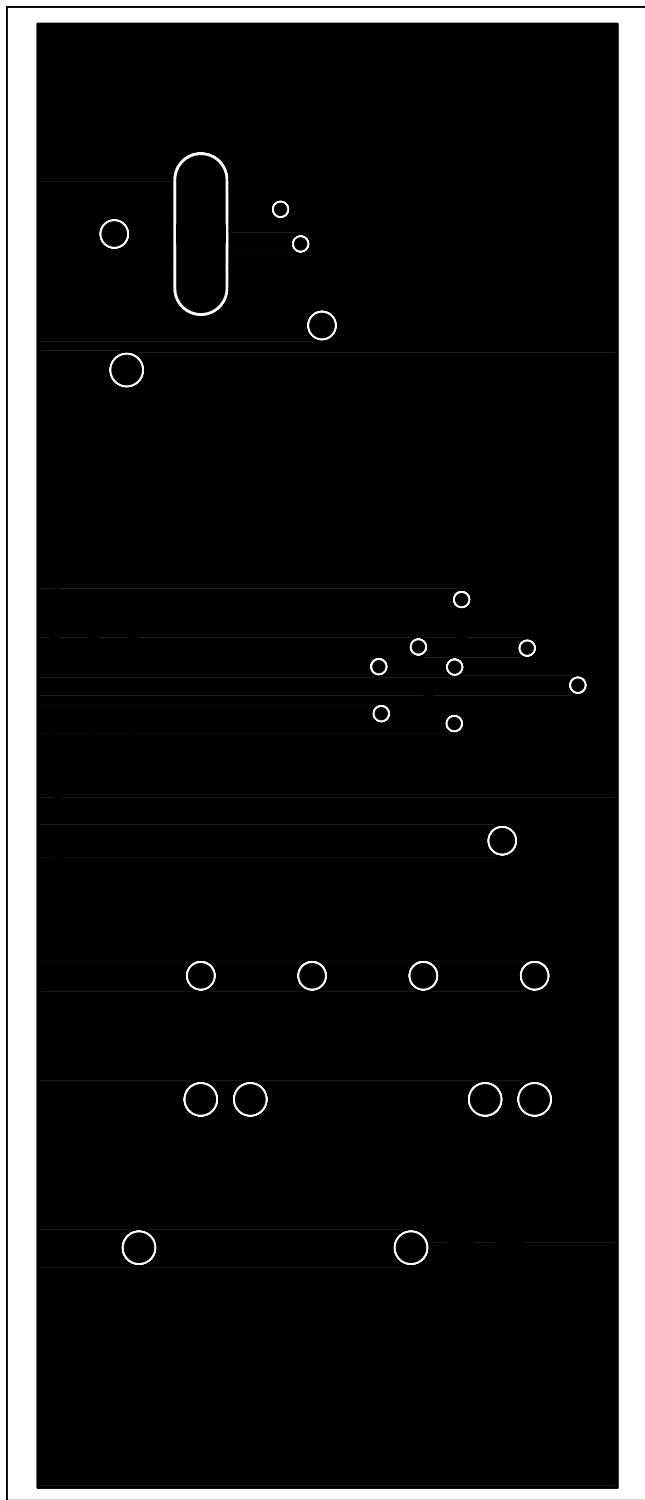

Figure 5. MAX3736 EV Kit PCB Layout—Ground Plane

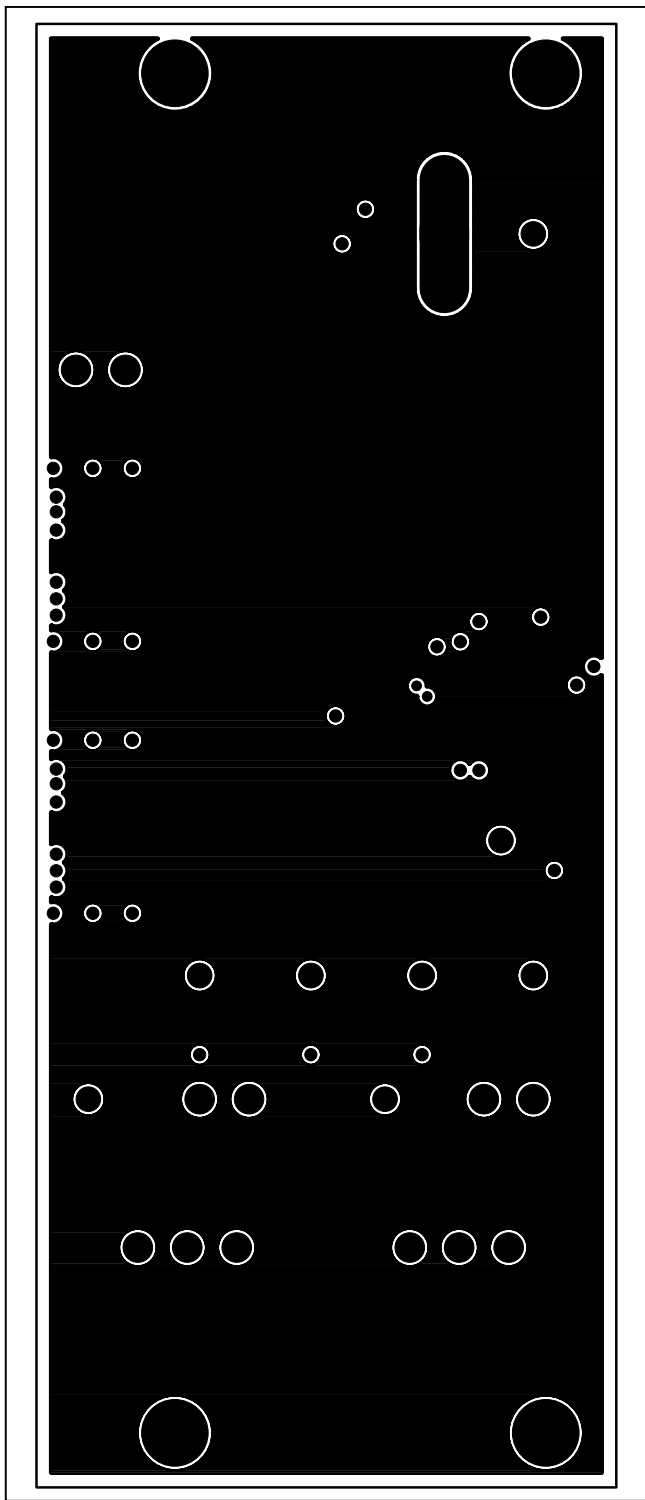

Figure 6. MAX3736 EV Kit PCB Layout—Power Plane

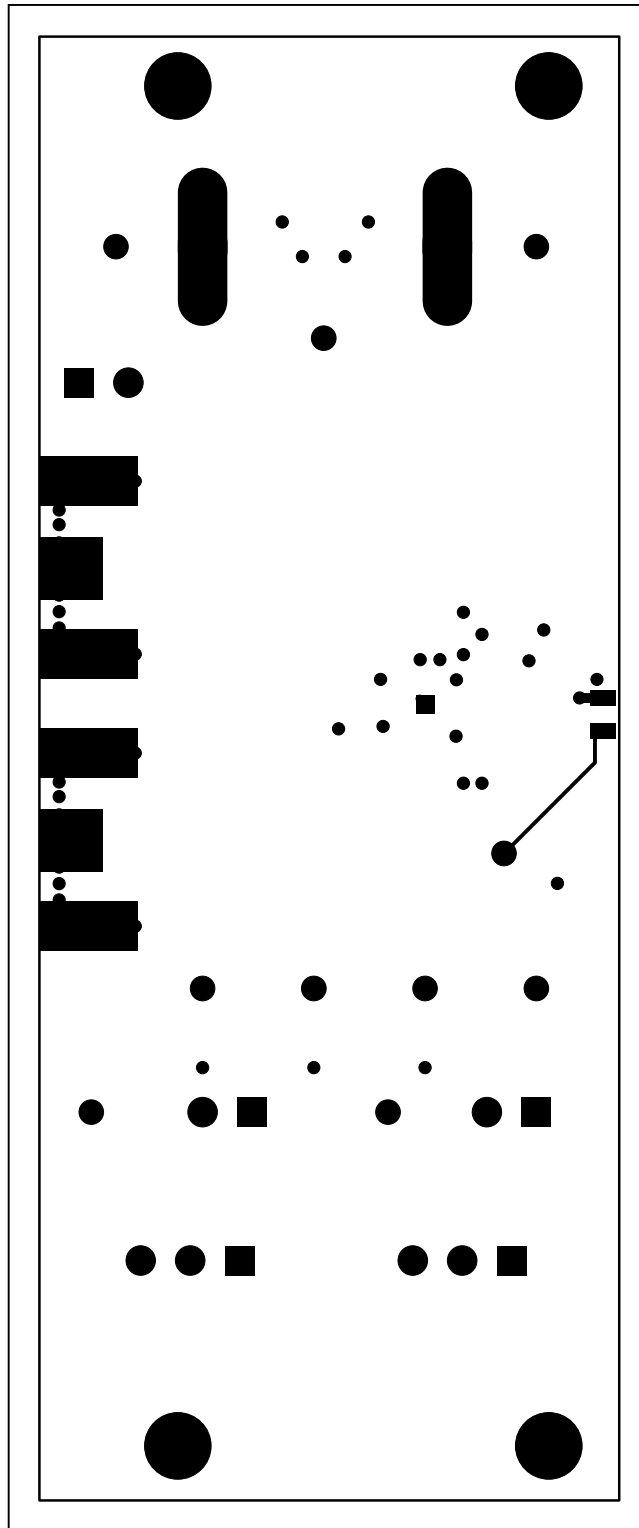

Figure 7. MAX3736 EV Kit PCB Layout—Solder Side

### Ordering Information

| PART         | TYPE   |
|--------------|--------|
| MAX3736EVKIT | EV Kit |

## Revision History

| REVISION NUMBER | REVISION DATE | DESCRIPTION     | PAGES CHANGED |
|-----------------|---------------|-----------------|---------------|
| 0               | 11/12         | Initial release | —             |

For pricing, delivery, and ordering information, please contact Maxim Direct at 1-888-629-4642, or visit Maxim Integrated's website at [www.maximintegrated.com](http://www.maximintegrated.com).

*Maxim Integrated cannot assume responsibility for use of any circuitry other than circuitry entirely embodied in a Maxim Integrated product. No circuit patent licenses are implied. Maxim Integrated reserves the right to change the circuitry and specifications without notice at any time.*



## Данный компонент на территории Российской Федерации

### Вы можете приобрести в компании MosChip.

Для оперативного оформления запроса Вам необходимо перейти по данной ссылке:

<http://moschip.ru/get-element>

Вы можете разместить у нас заказ для любого Вашего проекта, будь то серийное производство или разработка единичного прибора.

В нашем ассортименте представлены ведущие мировые производители активных и пассивных электронных компонентов.

Нашей специализацией является поставка электронной компонентной базы двойного назначения, продукции таких производителей как XILINX, Intel (ex.ALTERA), Vicor, Microchip, Texas Instruments, Analog Devices, Mini-Circuits, Amphenol, Glenair.

Сотрудничество с глобальными дистрибьюторами электронных компонентов, предоставляет возможность заказывать и получать с международных складов практически любой перечень компонентов в оптимальные для Вас сроки.

На всех этапах разработки и производства наши партнеры могут получить квалифицированную поддержку опытных инженеров.

Система менеджмента качества компании отвечает требованиям в соответствии с ГОСТ Р ИСО 9001, ГОСТ РВ 0015-002 и ЭС РД 009

### Офис по работе с юридическими лицами:

105318, г.Москва, ул.Щербаковская д.3, офис 1107, 1118, ДЦ «Щербаковский»

Телефон: +7 495 668-12-70 (многоканальный)

Факс: +7 495 668-12-70 (доб.304)

E-mail: [info@moschip.ru](mailto:info@moschip.ru)

Skype отдела продаж:

moschip.ru

moschip.ru\_4

moschip.ru\_6

moschip.ru\_9