

Ordering a market-ready enclosure® is made fast and affordable with our complete in-house capabilities. New Age provides machined openings to fit your PCB, pad printing for your graphics, custom enclosures, custom colors, final assembly, testing and fulfillment services to save you additional time and money. Ask your representative for a free quote today 805-595-1310.

## ***Fast and Affordable Customization***

**CNC Modifications  
Pad Printing  
Colored Resins  
EMI/RF Shielding  
Custom Enclosure  
Assembly & Testing**



ISO quality  
off-the-shelf  
to market-ready®

# **NEW AGE ENCLOSURES**

[www.NewAgeEnclosures.com](http://www.NewAgeEnclosures.com)

4330 Santa Fe Road • San Luis Obispo, CA 93401 • T 805.595.1310 • F 805.595.1024

**NOTES: UNLESS OTHERWISE SPECIFIED**

- CORNERS DRAWN SHARP TO BE R.005 MAXIMUM.
- EXTERIOR SURFACE TEXTURE TO BE LIGHT EDM FINISH. EQUIVELANT TO MT-11010.
- INTERIOR SURFACE TEXTURE: NONE.
- ALL INSIDE RADII .010R. ALL OUTSIDE RADII .020R MAX, UNLESS OTHERWISE SPECIFIED.
- ALL EXTERNAL DIMENSIONS AFFECTED BY THE DRAFT APPLY AT THE LARGE END OF THE FEATURE, AND ALL INTERNAL FEATURES AFFECTED BY THE DRAFT APPLY AT THE SMALL END OF THE FEATURE UNLESS OTHERWISE SPECIFIED.
- 1 DEGREE DRAFT IN THE DIRECTION OF PULL IS PERMISSIBLE UNLESS OTHERWISE SPECIFIED.
- MATERIAL / COLOR: ABS PLASTIC IS STANDARD IN BLACK OR WHITE. CUSTOM MATERIALS AND COLORS MAY BE AVAILABLE UPON REQUEST FOR QUOTE.
- PCB SIZES ARE RECOMMENDATIONS ONLY. FINAL SIZES AND VERIFICATION OF IT'S FIT ARE THE SOLE RESPONSIBILITY OF EACH OEM.
- CUSTOM LABEL RECESSES MAY BE AVAILABLE UPON REQUEST FOR QUOTE.
- ASSEMBLY SCREWS PROVIDED. PCB SCREWS AND BATTERY CONTACTS SOLD SEPERATELY.
- ANY SPECIFIC DIMENSIONS NOT PROVIDED HERE CAN BE OBTAINED FROM OUR SOLID MODELS (.STEP), AVAILABLE AT OUR WEBSITE. MODIFIED CUSTOMER MODELS ARE AVAILABLE UPON REQUEST.

R E V I S I O N					
REV.	DRAWN BY	ECO No	DESCRIPTION	DATE	APPROVED
1	M BOYER	---	RELEASE	27-Jun-09	D.C.
3	M BOYER	3109	CONSOLIDATE ALL 442710 CONFIG INTO ONE DOCUMENT	05-Sep-09	D.C.
4	M BOYER	3809	INCREASE HATCH RELIEF TOLERANCE	27-Oct-09	D.C.
4.1	M BOYER	0710	UPDATE FORMAT	26-Mar-10	

S442710(x) CONFIGURATIONS				
	-Blank	-WE	-WP	-LCD
S442710 COVER	1	1		
S442710 COVER W/ LCD CUTOUT				1
S442710 BATTERY BASE	1	1		1
S442710 WALL BASE		1	1	
S442710 HATCH	1	1		1
#4 HiLo SCREW 1.00"		1	1	
#4 HiLo SCREW .750"	2	1		2
#4 HiLo SCREW .500"	2	2		2
SINGLE AA CLIP	2*	2*		2*
DOUBLE AA CLIP	1*	1*		1*

\* = SOLD SEPERATELY

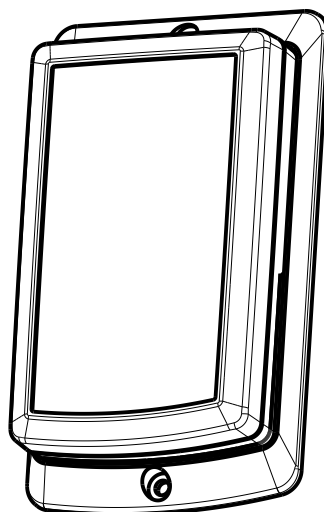

SCALE 0.500

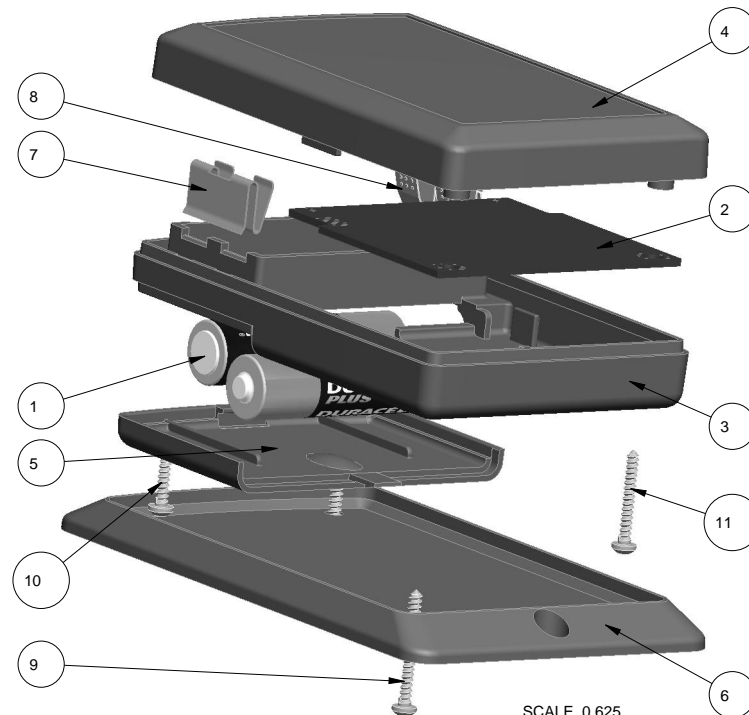

SCALE 0.625

ITEM	FILE NAME	DESCRIPTION	MATERIAL	COLOR	QTY.
11	NO_4_750_SCREW	HiLo4 x 3/4"	S-HiLo x 3/4"	ZINC PLATED	1
10	NO_4_500_SCREW	HiLo4 x 1/2"	S-HiLo x 1/2"	ZINC PLATED	1
9	NO_4_1000_SCREW	HiLo4 x 1"	S-HiLo x 1.0"	ZINC PLATED	2
8	SM_CLIP	PartNo: 209	SINGLE AA	NICKEL PLATED	2
7	LG_CLIP	PartNo:210	DOUBLE AA	NICKEL PLATED	1
6	442710-WALL	S442710 WALL - STANDARD	ABS	BLACK or WHITE	1
5	442710-HATCH	S442710E HATCH - STANDARD	ABS	BLACK or WHITE	1
4	442710-COVER	S442710 COVER - STANDARD	ABS	BLACK or WHITE	1
3	442710-BASE	S442710 BASE - STANDARD	ABS	BLACK or WHITE	1
2	442710-PCB	REFERENCE ONLY	CUSTOMER SUPPLIED	.062" THICK	1
1	AA_BATTERY	REFERENCE ONLY	CUSTOMER SUPPLIED	-	2

**BILL OF MATERIALS**

<p>THIRD ANGLE PROJECTION</p> <p>DO NOT SCALE DRAWING</p>	<p>TOLERANCES: UNLESS OTHERWISE SPECIFIED DIMENSIONS ARE IN U.S. INCHES:</p> <p>X.XX = .015 X.XXXX = .001                  X.XXX = .010 X.X" = 1°</p>		<p><b>NEW AGE ENCLOSURES</b></p> <p>4330 Santa Fe Road San Luis Obispo, CA. 93401                  ph. (805) 595-1310 fax (805) 595-1024  <a href="http://www.newageenclosures.com">www.newageenclosures.com</a></p>	
	<p>Customer's Part No: 442710</p>			
<p>NOTICE: THE INFORMATION AND DATA CONTAINED HEREIN IS CONSIDERED PROPRIETARY TO ALLTEC INTEGRATED MFG INC &amp; SHALL REMAIN THE EXCLUSIVE PROPERTY OF ALLTEC INTEGRATED MFG INC THE HOLDER WILL ASSUME CUSTODY AND CONTROL THAT THIS DOCUMENT WILL NOT BE COPIED, REPRODUCED, OR DISCLOSED WITHOUT THE EXPRESS WRITTEN CONSENT OF ALLTEC INTEGRATED MFG INC POSSESSION OF THIS DOCUMENT DOES NOT CONSTITUTE A GRANT TO MANUFACTURE ANY ITEMS.</p> <p>©2010</p>		<p>APPROVAL</p> <p>CHECK</p> <p>ENG.</p> <p>SCALE</p> <p>DRAWN BY</p>	<p>BY</p> <p>DATE</p>	<p>SIZE</p> <p>DRAWING NAME</p> <p>SHEET</p> <p>REV.DOC</p>
<p>M BOYER</p> <p>27-Jun-09</p>		<p>A</p> <p>442710X_R4_1</p>	<p>1 OF 11</p>	<p>4.1</p>

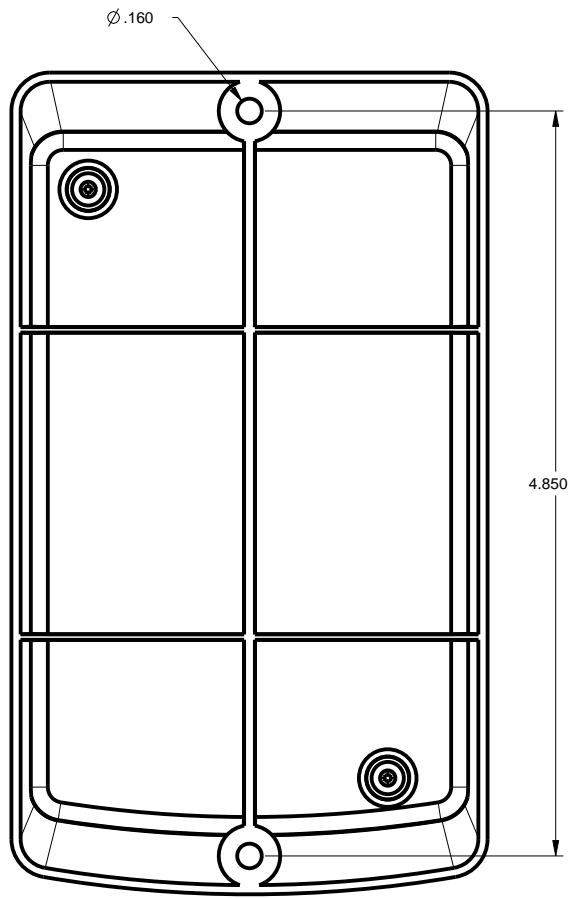
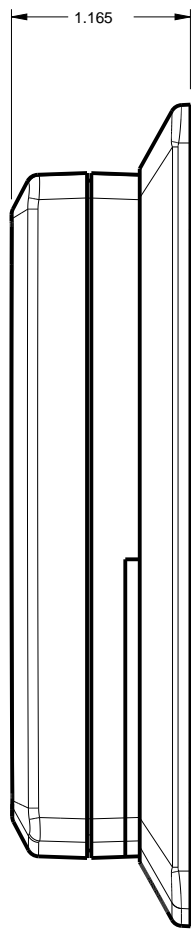
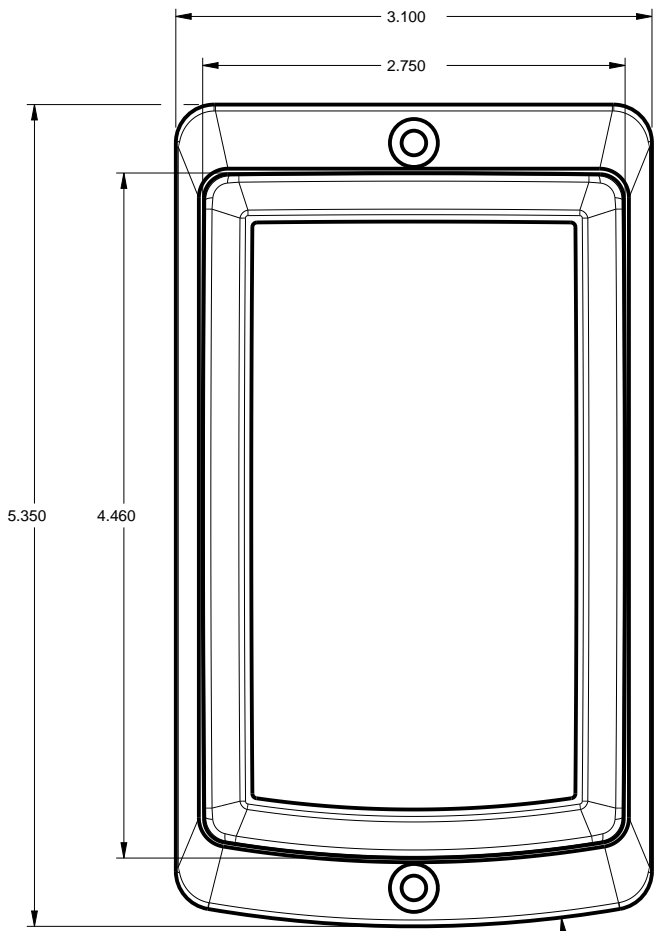

SCALE 0.800

R8.000

TOLERANCES: UNLESS OTHERWISE SPECIFIED DIMENSIONS ARE IN U.S. INCHES: X.XX = .015 X.XXXX = .001 X.XXX = .010 X.X° = 1°		<b>NEW AGE ENCLOSURES</b> 4330 Santa Fe Road San Luis Obispo, CA. 93401 ph. (805) 595-1310 fax (805) 595-1024 <a href="http://www.newageenclosures.com">www.newageenclosures.com</a>		
Customer's Part No: 442710		<b>MED. HANDHELD/WALL UTIL.          SXX-442710X ASSEMBLY</b>		
APPROVAL	BY			DATE
CHECK				
ENG.				
SCALE				
DRAWN BY	27-Jun-09	SIZE	DRAWING NAME A 442710X_R4_1	
		SHEET	REV.DOC	
		2 OF 11	4.1	

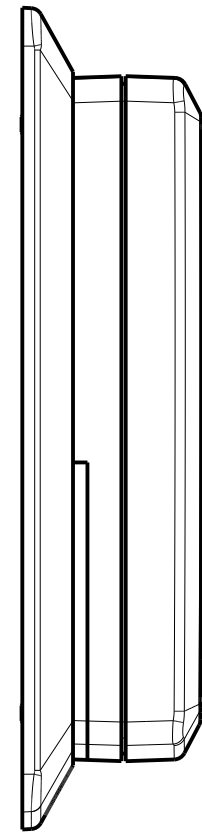
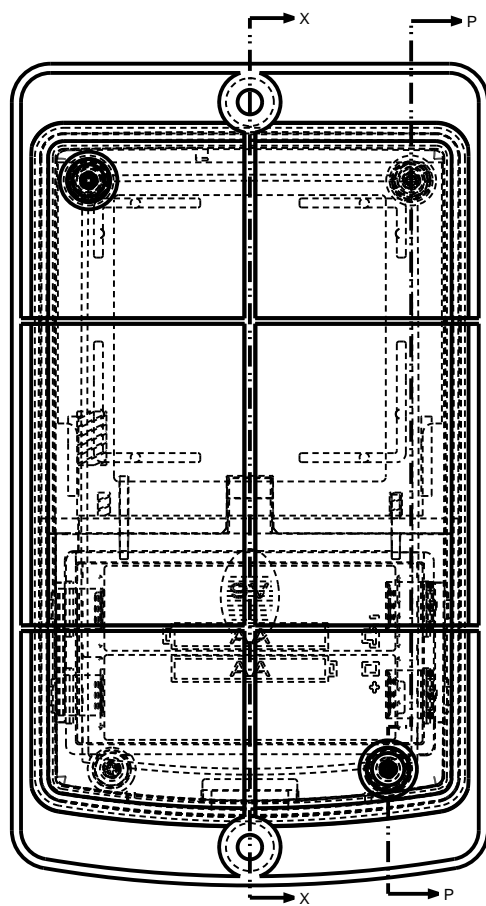
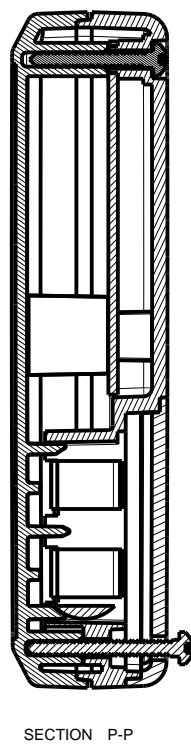
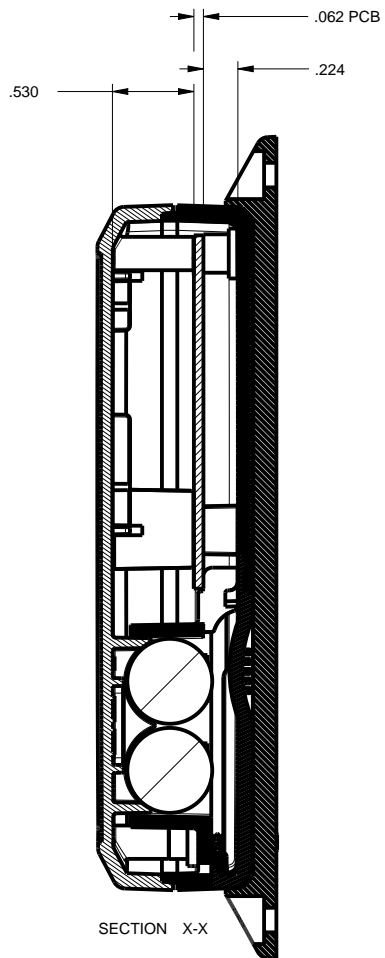

SCALE 0.800

TOLERANCES: UNLESS OTHERWISE SPECIFIED DIMENSIONS ARE IN U.S. INCHES: X.XX = .015 X.XXXX = .001 X.XXX = .010 X.X° = 1°		<b>NEW AGE ENCLOSURES</b> 4330 Santa Fe Road San Luis Obispo, CA. 93401 ph. (805) 595-1310 fax (805) 595-1024 <a href="http://www.newageenclosures.com">www.newageenclosures.com</a>	
Customer's Part No: 442710		<b>MED. HANDHELD/WALL UTIL.</b> <b>SXX-442710X ASSEMBLY</b>	
APPROVAL	BY	DATE	SIZE
CHECK			A
ENG.			DRAWING NAME
SCALE			442710X_R4_1
DRAWN BY			SHEET
M BOYER		27-Jun-09	3 OF 11
			REV.DOC
			4.1

# 442710 COVER

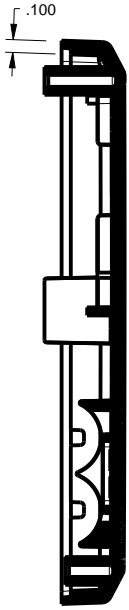

SECTION C-C

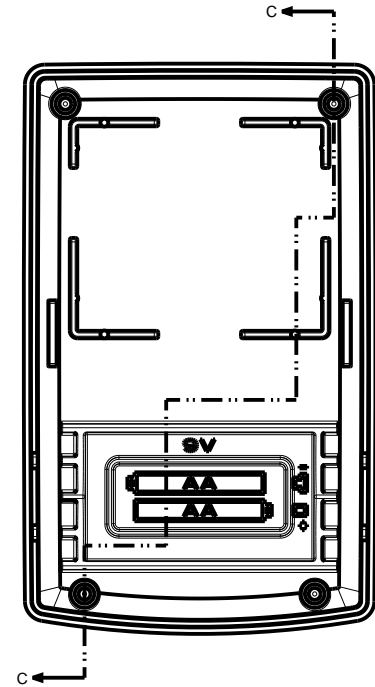
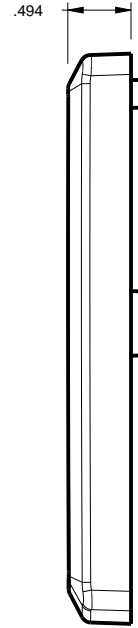
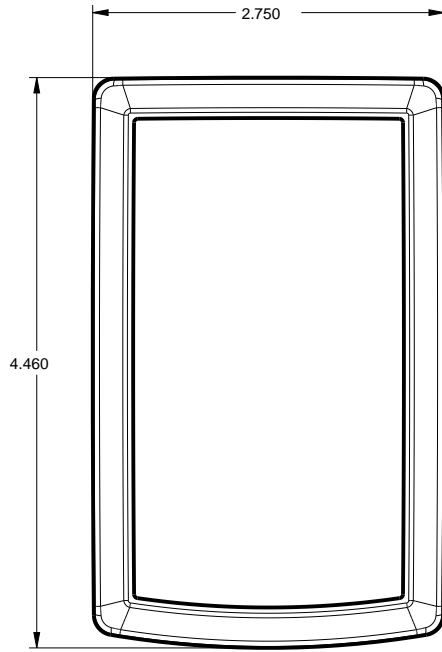
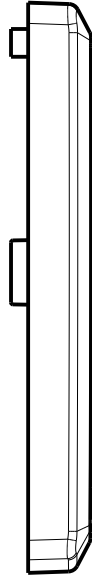

SCALE 0.666

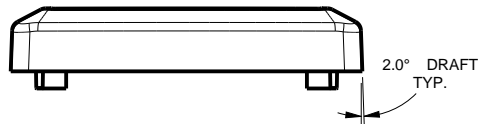

SPECIFIC GEOMETRIC DATA CAN BE OBTAINED FROM THE CAD MODEL AND DOWNLOADED VIA OUR WEBSITE. ALTERNATE FORMS OF CAD INFORMATION ARE AVAILABLE UPON REQUEST.

TOLERANCES: UNLESS OTHERWISE SPECIFIED DIMENSIONS ARE IN U.S. INCHES: X.XX = .015 X.XXXX = .001 X.XXX = .010 XX° = 1°		<b>NEW AGE ENCLOSURES</b> 4330 Santa Fe Road San Luis Obispo, CA. 93401 ph. (805) 595-1310 fax (805) 595-1024 <a href="http://www.newageenclosures.com">www.newageenclosures.com</a>	
Customer's Part No: 442710		<b>MED. HANDHELD/WALL UTIL.          SXX-442710X ASSEMBLY</b>	
APPROVAL	BY	DATE	SIZE
CHECK			A
ENG.			DRAWING NAME
SCALE			442710X_R4_1
DRAWN BY			SHEET
M BOYER		27-Jun-09	4 OF 11
			REV.DOC
			4.1

# 442710 COVER w/ LCD

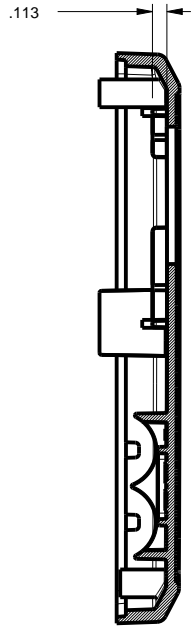

SECTION A-A

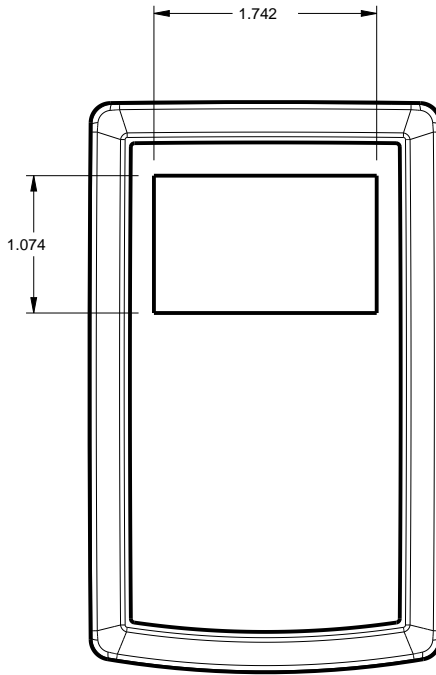
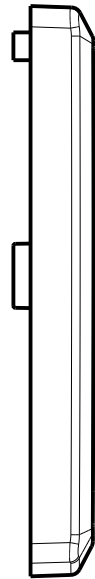

SCALE 0.666

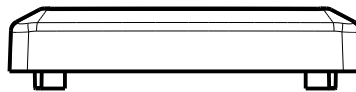
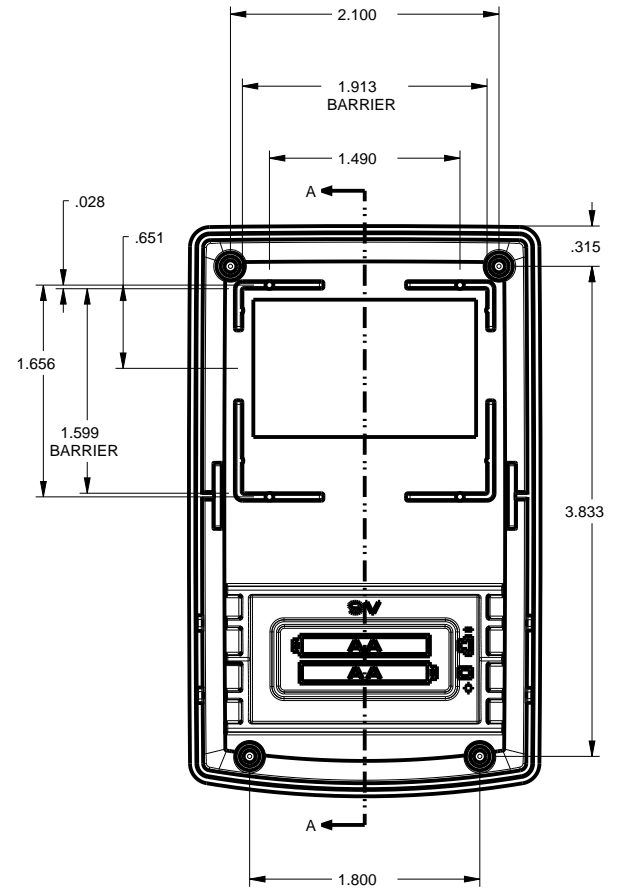
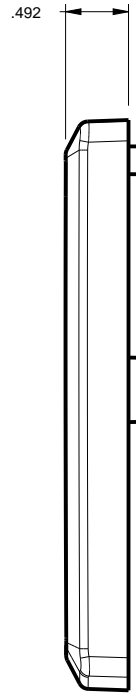

TOLERANCES: UNLESS OTHERWISE SPECIFIED DIMENSIONS ARE IN U.S. INCHES: X.XX = .015 X.XXXX = .001 X.XXX = .010 X.X° = 1°		<b>NEW AGE ENCLOSURES</b>	
Customer's Part No: 442710		4330 Santa Fe Road San Luis Obispo, CA. 93401 ph. (805) 595-1310 fax (805) 595-1024 <a href="http://www.newageenclosures.com">www.newageenclosures.com</a>	
APPROVAL	BY	DATE	<b>MED. HANDHELD/WALL UTIL. SXX-442710X ASSEMBLY</b>
CHECK			
ENG.			
SCALE			
DRAWN BY	M BOYER	27-Jun-09	SIZE A
			DRAWING NAME 442710X_R4_1
			SHEET 5 OF 11
			REV.DOC 4.1

# 442710 BASE

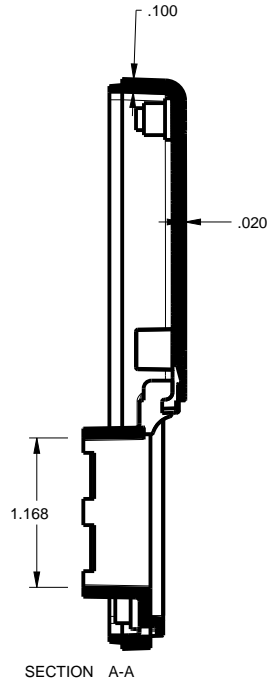
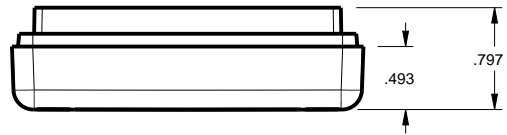

SECTION C-C

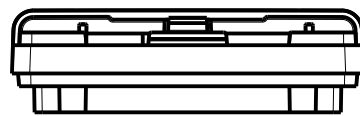
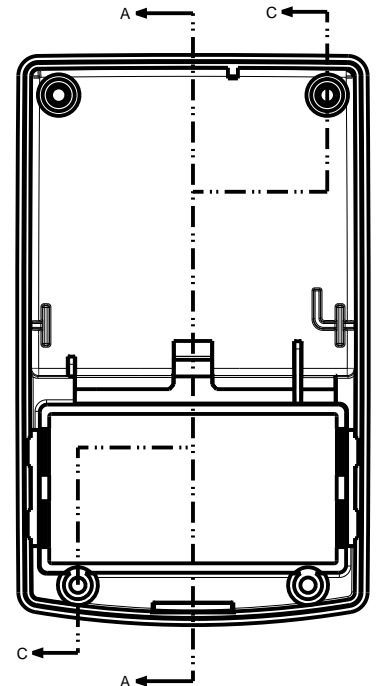
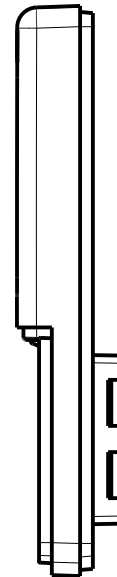
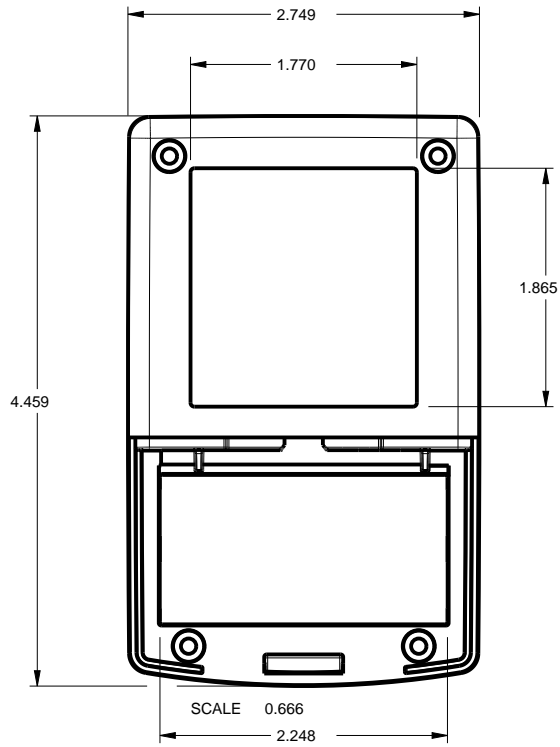
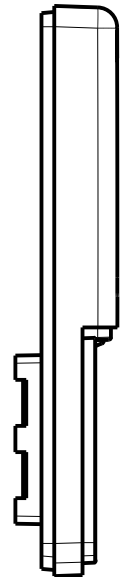
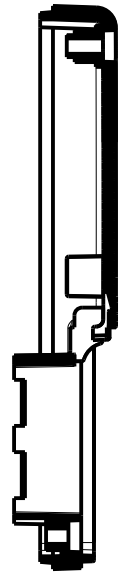

TOLERANCES: UNLESS OTHERWISE SPECIFIED DIMENSIONS ARE IN U.S. INCHES: X.XX = .015 X.XXXX = .001 X.XXX = .010 X.X° = 1°		<b>NEW AGE ENCLOSURES</b> 4330 Santa Fe Road San Luis Obispo, CA. 93401 ph. (805) 595-1310 fax (805) 595-1024 <a href="http://www.newageenclosures.com">www.newageenclosures.com</a>	
Customer's Part No: 442710			
APPROVAL	BY	DATE	<b>MED. HANDHELD/WALL UTIL.          SXX-442710X ASSEMBLY</b>
CHECK			
ENG.			
SCALE			
DRAWN BY	M BOYER	27-Jun-09	SIZE A DRAWING NAME 442710X_R4_1 SHEET 6 OF 11 REV.DOC 4.1



# 442710 HATCH

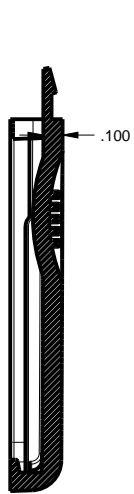
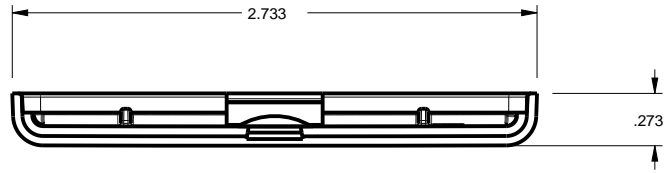

SECTION A-A

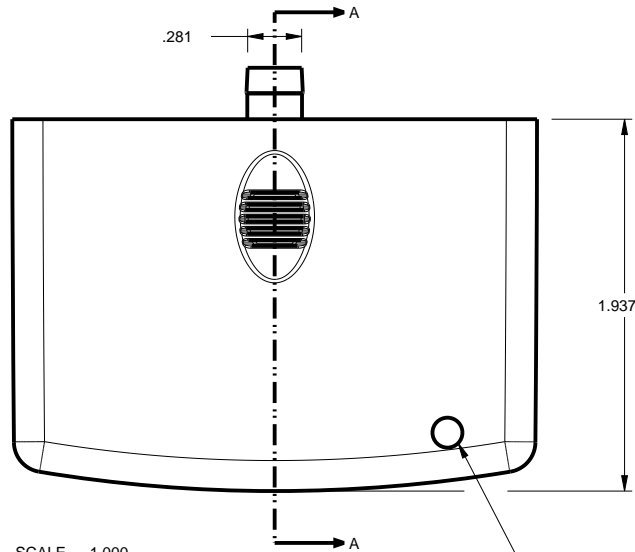

SCALE 1.000

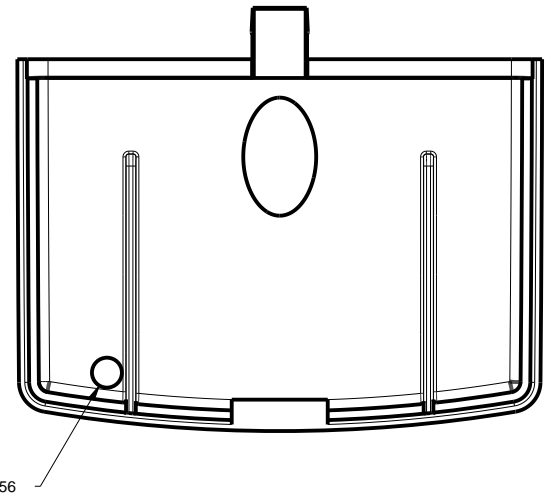
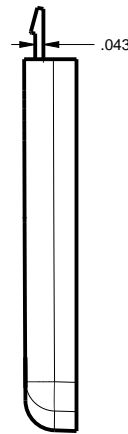

2nd OPERATION:  
CLEARANCE FOR ATTACHMENT  
OF WALL PLATE (S442710WE)

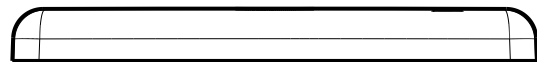

TOLERANCES: UNLESS OTHERWISE SPECIFIED DIMENSIONS ARE IN U.S. INCHES: X.XX = .015 X.XXXX = .001 X.XXX = .010 X.X° = 1°		<b>NEW AGE ENCLOSURES</b>	
Customer's Part No: 442710		4330 Santa Fe Road San Luis Obispo, CA. 93401 ph. (805) 595-1310 fax (805) 595-1024 <a href="http://www.newageenclosures.com">www.newageenclosures.com</a>	
APPROVAL	BY	DATE	MED. HANDHELD/WALL UTIL. SXX-442710X ASSEMBLY
CHECK			
ENG.			
SCALE			
DRAWN BY	M BOYER	27-Jun-09	SIZE A
			DRAWING NAME 442710X_R4_1
			SHEET 7 OF 11
			REV.DOC 4.1

# 442710 WALL PLATE

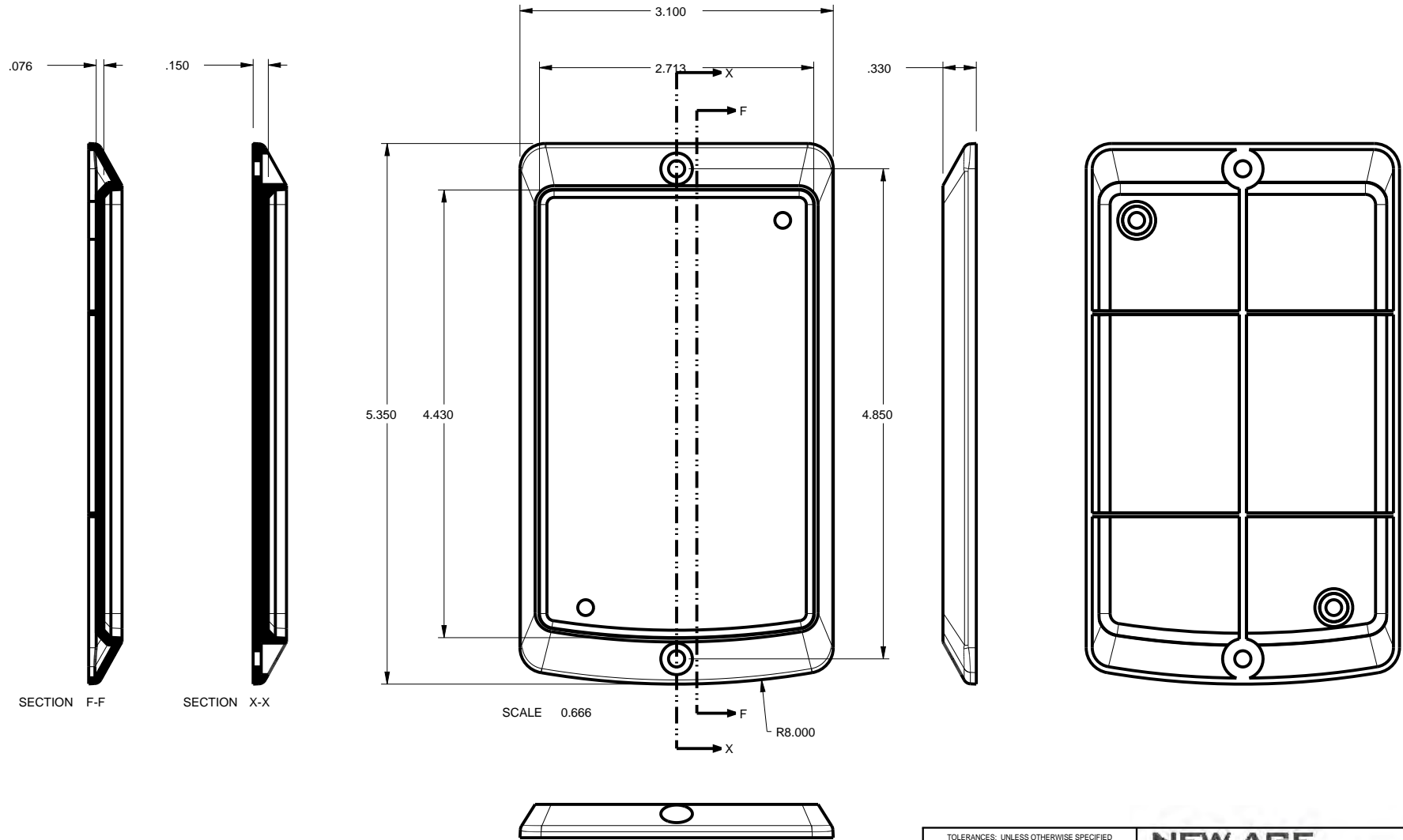

TOLERANCES: UNLESS OTHERWISE SPECIFIED DIMENSIONS ARE IN U.S. INCHES: X.XX = .015 X.XXXX = .001 X.XXX = .010 X.X° = 1°		<b>NEW AGE ENCLOSURES</b> 4330 Santa Fe Road San Luis Obispo, CA. 93401 ph. (805) 595-1310 fax (805) 595-1024 <a href="http://www.newageenclosures.com">www.newageenclosures.com</a>	
Customer's Part No: 442710		<b>MED. HANDHELD/WALL UTIL.          SXX-442710X ASSEMBLY</b>	
APPROVAL	BY	DATE	SCALE
CHECK			
ENG.			
DRAWN BY	M BOYER	27-Jun-09	SCALE
SIZE	A	DRAWING NAME	442710X_R4_1
SHEET	8 OF 11	REV.DOC	4.1

# S442710 PCB - CUSTOMER SUPPLIED

PCB SIZES ARE RECOMMENDATIONS ONLY. FINAL SIZES AND VERIFICATION OF IT'S FIT ARE THE SOLE RESPONSIBILITY OF THE OEM.

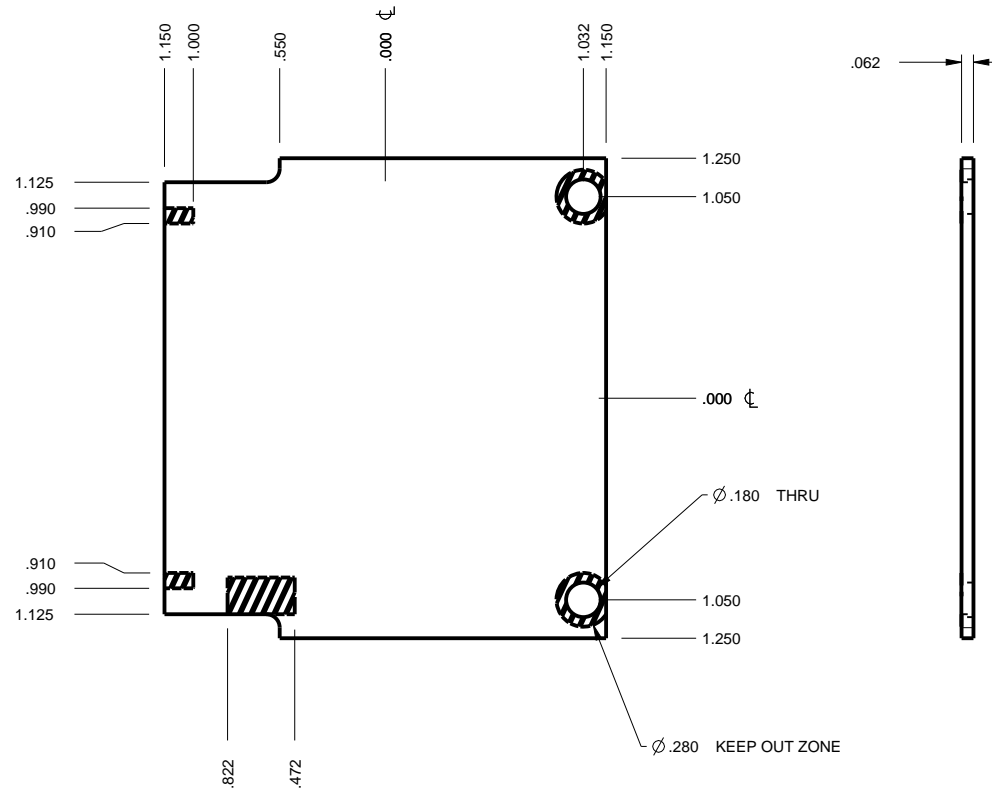

SCALE 1.000

TOLERANCES: UNLESS OTHERWISE SPECIFIED DIMENSIONS ARE IN U.S. INCHES: X.XX = .015 X.XXXX = .001 X.XXX = .010 X.X° = 1°		<b>NEW AGE ENCLOSURES</b> 4330 Santa Fe Road San Luis Obispo, CA. 93401 ph. (805) 595-1310 fax (805) 595-1024 <a href="http://www.newageenclosures.com">www.newageenclosures.com</a>	
Customer's Part No: 442710			
APPROVAL	BY	DATE	<b>MED. HANDHELD/WALL UTIL.                  SXX-442710X ASSEMBLY</b>
CHECK			
ENG.			
SCALE			
DRAWN BY	27-Jun-09		SIZE A DRAWING NAME 442710X_R4_1 SHEET 9 OF 11 REV.DOC 4.1

**SUGGESTED LABEL SIZE**

(w/ .01" minimum gap per side)  
CUSTOMER SUPPLIED

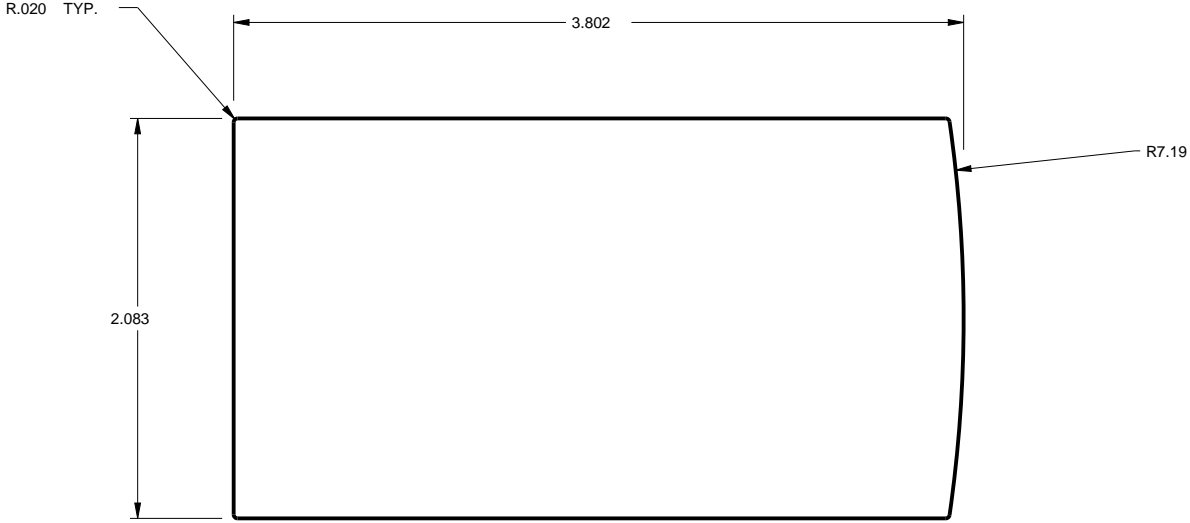

SCALE 1.000

<small>TOLERANCES: UNLESS OTHERWISE SPECIFIED DIMENSIONS ARE IN U.S. INCHES: X.XX = .015 X.XXXX = .001 X.XXX = .010 X.X° = 1°</small>		<b>NEW AGE ENCLOSURES</b> 4330 Santa Fe Road San Luis Obispo, CA. 93401 ph. (805) 595-1310 fax (805) 595-1024 <a href="http://www.newageenclosures.com">www.newageenclosures.com</a>				
Customer's Part No: 442710						
APPROVAL	BY	DATE	<b>MED. HANDHELD/WALL UTIL. SXX-442710X ASSEMBLY</b>			
CHECK						
ENG.						
SCALE						
DRAWN BY			SIZE	DRAWING NAME	SHEET	REV.DOC
M BOYER		27-Jun-09	A	442710X_R4_1	10 OF 11	4.1

## 2nd OPERATION DETAILS

New Age Enclosures DELIVERS YOUR ENCLOSURE MARKET-READY WITH IN-HOUSE  
CNC MACHINING, PAD PRINTING, ASSEMBLY, AND FULFILLMENT.  
ALL SURFACES AND AREAS ARE AVAILABLE FOR CNC ALTERATION BY New Age Enclosures  
CALL (805) 595-1310 FOR PRICING AND SCHEDULE.  
THE INSIDE RADIUS OF ANY MACHINED FEATURES SHOULD BE NO SMALLER THAN .031"

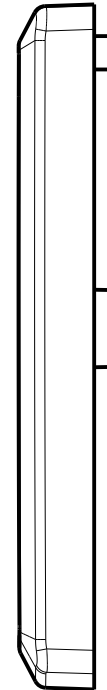
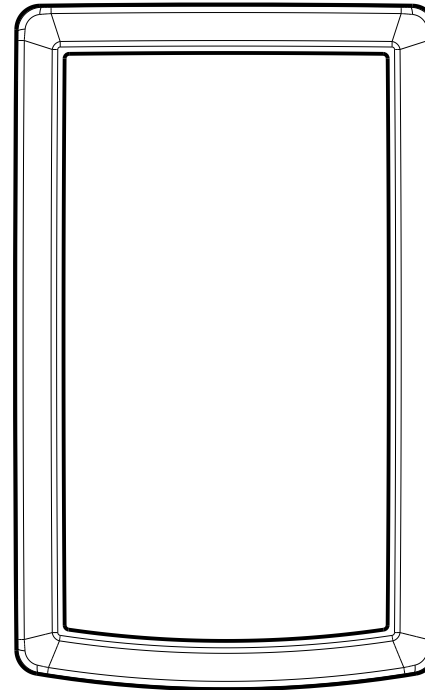
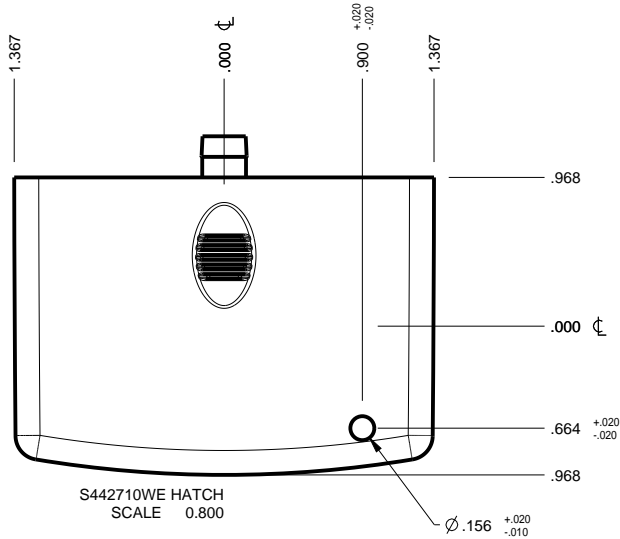

S442710 COVER  
SCALE 0.800

SXX-442710WE-XXX HATCH - ABS, BLACK					
STEP NO	DESCRIPTION	CUTTER	FIXTURE	ORIENTATION	PROGRAM
1	∅.156 ASSEMBLY HOLE	T2 = .062" EM	113	USE ENCLOSURE ASSEMBLY	o4977
SXX-442710-XXX COVER - ABS, BLACK					
STEP NO	DESCRIPTION	CUTTER	FIXTURE	ORIENTATION	PROGRAM
2	-	T2 = .062" EM	113	CENTER BLOCK - RAD. RIGHT	-
SXX-442710-XXX BASE - ABS, BLACK					
STEP NO	DESCRIPTION	CUTTER	FIXTURE	ORIENTATION	PROGRAM
3	-	T2 = .062" EM	113	CENTER BLOCK - RAD. RIGHT	-

TOLERANCES: UNLESS OTHERWISE SPECIFIED  
DIMENSIONS ARE IN U.S. INCHES:  
X.XX = .015 X.XXXX = .001  
X.XXX = .010 X.X° = 1°

NEW AGE ENCLOSURES  
Customer's Part No: 442710

APPROVAL BY DATE

CHECK

ENG.

SCALE

DRAWN BY  
M BOYER 27-Jun-09

**NEW AGE  
ENCLOSURES**

4330 Santa Fe Road San Luis Obispo, CA. 93401  
ph. (805) 595-1310 fax (805) 595-1024  
[www.newageenclosures.com](http://www.newageenclosures.com)

**MED. HANDHELD/WALL UTIL.  
SXX-442710X ASSEMBLY**

SIZE A	DRAWING NAME 442710X_R4_1	SHEET 11 OF 11	REV.DOC 4.1
-----------	------------------------------	-------------------	----------------

# Mouser Electronics

Authorized Distributor

Click to View Pricing, Inventory, Delivery & Lifecycle Information:

## New Age Enclosures:

[S1A-442710-WE](#) [S1A-442710](#) [S3A-442710-WP](#) [S3A-442710-WE](#) [S3A-442710](#) [S1A-442710-WP](#) [S1A-442710LCD](#)

## Данный компонент на территории Российской Федерации

### Вы можете приобрести в компании MosChip.

Для оперативного оформления запроса Вам необходимо перейти по данной ссылке:

<http://moschip.ru/get-element>

Вы можете разместить у нас заказ для любого Вашего проекта, будь то серийное производство или разработка единичного прибора.

В нашем ассортименте представлены ведущие мировые производители активных и пассивных электронных компонентов.

Нашей специализацией является поставка электронной компонентной базы двойного назначения, продукции таких производителей как XILINX, Intel (ex.ALTERA), Vicor, Microchip, Texas Instruments, Analog Devices, Mini-Circuits, Amphenol, Glenair.

Сотрудничество с глобальными дистрибьюторами электронных компонентов, предоставляет возможность заказывать и получать с международных складов практически любой перечень компонентов в оптимальные для Вас сроки.

На всех этапах разработки и производства наши партнеры могут получить квалифицированную поддержку опытных инженеров.

Система менеджмента качества компании отвечает требованиям в соответствии с ГОСТ Р ИСО 9001, ГОСТ РВ 0015-002 и ЭС РД 009

### Офис по работе с юридическими лицами:

105318, г.Москва, ул.Щербаковская д.3, офис 1107, 1118, ДЦ «Щербаковский»

Телефон: +7 495 668-12-70 (многоканальный)

Факс: +7 495 668-12-70 (доб.304)

E-mail: [info@moschip.ru](mailto:info@moschip.ru)

Skype отдела продаж:

moschip.ru

moschip.ru\_4

moschip.ru\_6

moschip.ru\_9