

777 SERIES

3-Phase Current & Voltage Monitor



Wiring Diagram

TYPICAL WIRING DIAGRAM FOR MODEL 777 (2 to 90 A)

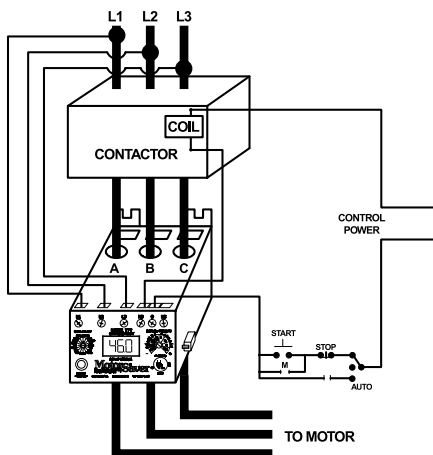

CURRENT TRANSFORMER WIRING DIAGRAM FOR MODEL 777 (80 to 800 A)

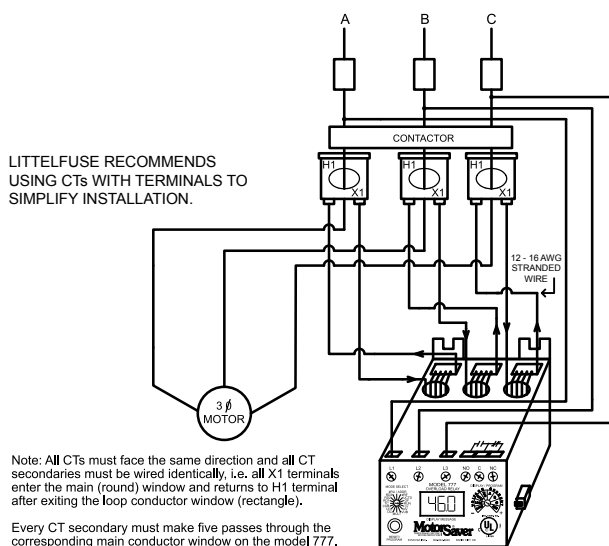

Note: All CTs must face the same direction and all CT secondaries must be wired identically, i.e. all X1 terminals enter the main (round) window and returns to H1 terminal after exiting the loop conductor window (rectangle).

Every CT secondary must make five passes through the corresponding main conductor window on the model 777.

Every CT secondary must make a single pass through the corresponding main conductor window on the LR versions of the 777 Plus Series.

Description

The 777 is a fully programmable electronic overload relay designed to protect any motor drawing 2-800 full load amps (external CTs are required above 90 amps). The 777 (family of products) is for 3-phase 200-480 V ac applications, with several specialized units for other voltage ranges and unique applications. Common applications include conveyor systems, HVAC equipment, saws and grinders, fan motors, and almost any pumping application. Some unique applications include use with a Subtrol* equipped Franklin submersible motor to detect high motor temperatures and applications where a fast linear trip is required.

All of the overload relays provide unsurpassed protection by combining overload, voltage, phase loss and reversal, voltage and current unbalance, power monitoring, and underload based on current in one package. For standalone applications, the units incorporate a 3-digit LED display that is used for programming, providing real-time operational information and displaying diagnostic codes to aid in troubleshooting a fault condition. The units also feature a communications port that can be used with communication modules listed in the 777 accessories section to form a Modbus, DeviceNet*, Profibus, or Ethernet network. Up to 99 units can be remotely monitored and controlled from a PC, PLC, or SCADA system, and data logging through a PC with the optional Solutions software. This capability allows for a simple, cost-effective way to meet new requirements for arc-flash safety.

Features & Benefits

FEATURES	BENEFITS
Built-in display	Visual indication for programming, viewing real-time voltage or current, and last fault code
Programmable voltage and current settings	Allows usage on wide range of systems
3 selectable restart options	Choose from automatic, semi-automatic, or manual to best meet individual application needs
3 programmable restart delay timers	Program separate restart delay time for rapid cycle protection, motor cool down, and dry-well recovery
Remote display compatibility	Increases safety through remote display of real-time data and fault history, without the need to open the cabinet. Aids with arc flash safety regulations
Flexible reset	Reset can be done through pushbutton on relay or remotely with optional 777-MRSW or OL-Reset remote reset kit
Network communications capability	Compatible with Modbus, DeviceNet*, Profibus, or Ethernet using optional communications module

Ordering Information

See next page.

*Subtrol and DeviceNet are trademarks of their respective owners.

777 SERIES

Ordering Information

MODEL	LINE VOLTAGE	MOTOR FULL AMP RANGE	DESCRIPTION
777-P2	200-480 V ac	2-800 A (external CTs required above 90 A)	Provides low and high power trip*, linear overcurrent trip, and 480 VA @ 240 V ac output SPDT relay contacts
777-LR-P2	200-480 V ac	1-800 A (external CTs required above 9 A)	Protects low range motors when wired directly or with 10-800 FLA with use of external CTs
777-HVR-P2	340-480 V ac	2-800 A (external CTs required above 90 A)	Provides low and high power trip*, linear overcurrent trip, and 470 VA @ 600 V ac output SPDT relay contacts. Required when a control power transformer (CPT) is not used with a 480 V system
777-HVR-LR-P2	340-480 V ac	1-800 A (external CTs required above 9 A)	Provides low and high power trip*, linear overcurrent trip, and 470 VA @ 600 V ac output SPDT relay contacts. Required when a control power transformer (CPT) is not used with a 480 V system
777-575-P2	500-600 V ac	2-800 A (external CTs required above 90 A)	Provides low and high power trip*, linear overcurrent trip, and 480 VA @ 240 V ac output SPDT relay contacts. Used in Canada and NE USA where 575 V utility power services are common
777-575-LR-P2	500-600 V ac	1-800 A (external CTs required above 9 A)	Provides low and high power trip*, linear overcurrent trip, and 480 VA @ 240 V ac output SPDT relay contacts. Used in Canada and NE USA where 575 V utility power services are common
777-MV-P2	100-240 V ac	10-800 A with external CTs	Provides low and high power trip*, linear overcurrent trip, and 480 VA @ 240 V ac output SPDT relay contacts. Designed for Medium Voltage applications where both PTs and CTs are used. Has built in multipliers for 25.5, 50.5, 100.5 CTs. The voltage unbalance, single-phase and reverse phase protection can be disabled for applications where only the PTs are used
777-HRG-P2	200-480 V ac	2-90 A only	Provides low and high power trip*, linear overcurrent trip, and 480 VA @ 240 V ac output SPDT relay contacts. Designed for high resistance grounding systems that incorporate an external zero-sequence CT that correspond with the built in multipliers to detect ground faults
777-LR-HRG-P2	200-480 V ac	10-800 A (external CTs required, external)	Overload relays designed for high resistance grounding systems that incorporate an external zero-sequence CTs that correspond with the built in multipliers to detect ground faults
777-575-HRG-P2	500-600 V ac	2-90 A only	Provides low and high power trip*, linear overcurrent trip, and 480 VA @ 240 V ac output SPDT relay contacts. Used in Canada and NE USA where 575 V utility power services are common. Designed for high resistance grounding systems that incorporate an external zero-sequence CT that correspond with the built in multipliers to detect ground faults
777-575-LR-HRG-P2	500-600 V ac	10-800 A with external CTs	Provides low and high power trip*, linear overcurrent trip, and 480 VA @ 240 V ac output SPDT relay contacts. Used in Canada and NE USA where 575 V utility power services are common. Designed for high resistance grounding systems that incorporate an external zero-sequence CT that correspond with the built in multipliers to detect ground faults
777-FT	200-480 V ac	2-800 A (external CTs required above 90 A)	Provides linear overcurrent trip and 480 VA @ 240 V ac output SPDT relay contacts. Also known as shock relay, it is designed for fast linear trip applications. Overcurrent trip delay can be set ranging from less than 500 ms - 70 seconds. Low trip delay is ideal in chain drive and drive linkage applications to prevent breaking in overload or jam situations. Other applications include sewage clarifiers, mixers, augers, and conveyors. Longer trip delay is ideal for motor test panels in rewind shops. Also includes adjustable motor acceleration time and overcurrent trip delay time when the faster linear trip mode is used
777-TS	200-480 V ac	2-800 A (external CTs required above 90 A)	Provides 480 VA @ 240 V ac output SPDT relay contacts. For use with Subtrol equipped Franklin submersible motors to detect high motor temperatures
777-LR-TS	200-480 V ac	1-9 A only	Provides 480 VA @ 240 V ac output SPDT relay contacts. For use with Subtrol equipped Franklin submersible motors to detect high motor temperatures
777-575-TS	500-600 V ac	2-800 A (external CTs required above 90 A)	Provides 480VA @ 240 V ac output SPDT relay contacts. For use with Subtrol equipped Franklin submersible motors with nominal 500-600 V ac range to detect high motor temperatures
777VA-02	200-480 V ac	2-800 A (external CTs required above 90 A)	Provides low and high power trip*, linear overcurrent trip, and 480 VA @ 240 V ac output SPDT relay contacts. Has restart delay 1 setpoints of 2-500 minutes and undercurrent trip delay setpoints of 2-60 minutes.
777VA-03	200-480 V ac	2-800 A (external CTs required above 90 A)	Provides low and high power trip*, linear overcurrent trip, and 480 VA @ 240 V ac output SPDT relay contacts. For use with static and rotary single to 3-phase converters. High and low voltage trip feature only applies to the utility supplied power. Works well with unloaded phase converters because the relay ignores severely unbalanced voltages

* Network programmable only

777 SERIES

Accessories



RS485MS-2W Communication Module
(for limited Modbus capabilities) Required to enable the Modbus communications function on Model 77X-type products.



CIO-MB/CIO-120-MB Communication Module
Modbus-RTU interfaces capable of providing discrete control and monitoring of an overload relay over a Modbus network.



CIO-DN-P/CIO-120-DN-P Communication Module
DeviceNet™ interfaces capable of providing discrete control and monitoring of motor starters, drives and other devices over a DeviceNet™ network.



CIO-777-PR Communication Module
Profibus interface capable of providing discrete control and monitoring of motor starters, drives and other devices over a Profibus network.



CIO-EN (non-POE) Communication Module
Modbus-TCP and Modbus-RTU interface capable of providing discrete control and monitoring of an overload relay over a Modbus network.



Communication Adapters

- RS485-RS232-Converter with cable & plug
- RS485-USB-Converter with cable & plug
- RS232-USB-Converter

 Specifications match industry standard.



RM1000 Remote Monitor
The RM1000/777 motor management system combines unsurpassed electronic motor protection and critical, user-friendly, motor monitoring for up to 16 devices.



RM2000 Remote Monitor
The RM2000/777 motor management system combines unsurpassed electronic motor protection and critical, user-friendly, motor monitoring with event storage and real-time clock for date and time stamp.



Solutions Software: Solutions-M
Software features include data logging, real-time data monitoring and fault and event monitoring.



777-MRSW Manual Remote Reset Kit
Allows the 777 line of MotorSaver® and PumpSaver® products to be manually reset without opening the panel door.



OL-RESET Manual Remote Reset Kit
Allows the 777 line of MotorSaver® and PumpSaver® products to be manually reset without opening the panel door.

Specifications

Functional Characteristics

Frequency 50/60 Hz
TC- Overcurrent Trip Class (777 Plus Series units) 02-60, J02-J60, L00-L60 or Off
TC- Overcurrent Trip Class (77C, 777 non-Plus Series units) 5, 10, 15, 20, 30
 (J prefix enables jam protection feature)

Output Characteristics

Output Contact Rating (SPDT - Form C) 480 VA @ 240 V ac, B300
Pilot duty rating 10 A @ 240 V ac
General purpose 470 VA @ 600 V ac, B600

General Characteristics

Ambient Temperature Range
Operating -20 °C to 70 °C (-4 °F to 158 °F)
Storage -40 °C to 80 °C (-40 °F to 176 °F)
Accuracy
Voltage ±1 %
Current ±3 % (<100 amps direct)
GF Current ±15 %
Timing (777 Plus Series units) ±0.5 second
Timing (77C, 777 non-Plus Series units) 5 % +1 second
Repeatability
Voltage ±0.5 % of nominal voltage
Current ±1 % (<100 amps direct)
Maximum Input Power 10 W
Pollution Degree 3
Class of Protection IP20
Relative Humidity 10-95 %, non-condensing per IEC 68-2-3
Terminal Torque 7 in.-lbs.
Standards Passed
Electrostatic Discharge (ESD) IEC 61000-4-2, Level 3, 6 kV contact, 8 kV air
Radio Frequency Immunity (RFI), Conducted IEC 61000-4-6, Level 3 10 V/m
Radio Frequency Immunity (RFI), Radiated IEC 61000-4-3, Level 3 10 V/m
Fast Transient Burst IEC 61000-4-4, Level 3, 3.5 kV input power
Short Circuit 100 kA
Surge
IEC 61000-4-5, Level 3, 2 kV line-to-line; Level 4, 4 kV line-to-ground
ANSI/IEEE C62.41 Surge and Ring Wave Compliance to a level of 6 kV line-to-line
Hi-potential Test Meets UL 508 (2 x rated V +1000 V for 1 minute)
Vibration IEC 68-2-6, 10-55 Hz, 1 mm peak-to-peak, 2 hours, 3 axis
Shock IEC 68-2-27, 30 g, 3 axis, 11 ms duration, half-sine pulse
Safety Marks
UL UL 508, UL 1053 (File #E68520)
CE IEC 60947-1, IEC 60947-5-1
CSA C22.2
Maximum Conductor Size (with insulation) through 777/77C 0.65"
Dimensions **H** 77.47 mm (3.05"); **W** 97.79 mm (3.85"); **D** 128.27 mm (5.05")
Weight 1.56 lbs. (24.96 oz., 707.6 g)
Mounting Method Surface mount (4 - #8 screws) or DIN-rail mount

Данный компонент на территории Российской Федерации

Вы можете приобрести в компании MosChip.

Для оперативного оформления запроса Вам необходимо перейти по данной ссылке:

<http://moschip.ru/get-element>

Вы можете разместить у нас заказ для любого Вашего проекта, будь то серийное производство или разработка единичного прибора.

В нашем ассортименте представлены ведущие мировые производители активных и пассивных электронных компонентов.

Нашей специализацией является поставка электронной компонентной базы двойного назначения, продукции таких производителей как XILINX, Intel (ex.ALTERA), Vicor, Microchip, Texas Instruments, Analog Devices, Mini-Circuits, Amphenol, Glenair.

Сотрудничество с глобальными дистрибьюторами электронных компонентов, предоставляет возможность заказывать и получать с международных складов практически любой перечень компонентов в оптимальные для Вас сроки.

На всех этапах разработки и производства наши партнеры могут получить квалифицированную поддержку опытных инженеров.

Система менеджмента качества компании отвечает требованиям в соответствии с ГОСТ Р ИСО 9001, ГОСТ РВ 0015-002 и ЭС РД 009

Офис по работе с юридическими лицами:

105318, г.Москва, ул.Щербаковская д.3, офис 1107, 1118, ДЦ «Щербаковский»

Телефон: +7 495 668-12-70 (многоканальный)

Факс: +7 495 668-12-70 (доб.304)

E-mail: info@moschip.ru

Skype отдела продаж:

moschip.ru

moschip.ru_4

moschip.ru_6

moschip.ru_9