

# BGA735N16

High Linearity Tri-Band LTE/UMTS LNA  
(2600/2300/2100, 1900/1800, 900/800/700 MHz)

## Data Sheet

Revision 3.8, 2010-12-23

**Edition 2010-12-23**

**Published by  
Infineon Technologies AG  
81726 Munich, Germany**

**© 2010 Infineon Technologies AG  
All Rights Reserved.**

### **Legal Disclaimer**

The information given in this document shall in no event be regarded as a guarantee of conditions or characteristics. With respect to any examples or hints given herein, any typical values stated herein and/or any information regarding the application of the device, Infineon Technologies hereby disclaims any and all warranties and liabilities of any kind, including without limitation, warranties of non-infringement of intellectual property rights of any third party.

### **Information**

For further information on technology, delivery terms and conditions and prices, please contact the nearest Infineon Technologies Office ([www.infineon.com](http://www.infineon.com)).

### **Warnings**

Due to technical requirements, components may contain dangerous substances. For information on the types in question, please contact the nearest Infineon Technologies Office.

Infineon Technologies components may be used in life-support devices or systems only with the express written approval of Infineon Technologies, if a failure of such components can reasonably be expected to cause the failure of that life-support device or system or to affect the safety or effectiveness of that device or system. Life support devices or systems are intended to be implanted in the human body or to support and/or maintain and sustain and/or protect human life. If they fail, it is reasonable to assume that the health of the user or other persons may be endangered.

**BGA735N16 High Linearity Tri-Band LTE/UMTS LNA**  
**(2600/2300/2100, 1900/1800, 900/800/700 MHz)**

**Revision History: 2010-12-23, Revision 3.8**

**Previous Revision: 2010-09-06, Revision 3.7**

Page	Subjects (major changes since last revision)
13-14	Added LTE bands 12, 13, 14, 17
21-22	Added LTE bands 38, 40

**Trademarks of Infineon Technologies AG**

AURIX™, BlueMoon™, C166™, CanPAK™, CIPOS™, CIPURSE™, COMNEON™, EconoPACK™, CoolMOS™, CoolSET™, CORECONTROL™, CROSSAVE™, DAVE™, EasyPIM™, EconoBRIDGE™, EconoDUAL™, EconoPIM™, EiceDRIVER™, eupec™, FCOS™, HITFET™, HybridPACK™, I<sup>2</sup>RF™, ISOFACE™, IsoPACK™, MIPAQ™, ModSTACK™, my-d™, NovalithIC™, OmniTune™, OptiMOS™, ORIGA™, PRIMARION™, PrimePACK™, PrimeSTACK™, PRO-SIL™, PROFET™, RASIC™, ReverSave™, SatRIC™, SIEGET™, SINDRION™, SIPMOS™, SMARTi™, SmartLEWIS™, SOLID FLASH™, TEMPFET™, thinQ!™, TRENCHSTOP™, TriCore™, X-GOLD™, X-PMU™, XMM™, XPOSYS™.

**Other Trademarks**

Advance Design System™ (ADS) of Agilent Technologies, AMBA™, ARM™, MULTI-ICE™, KEIL™, PRIMECELL™, REALVIEW™, THUMB™, µVision™ of ARM Limited, UK. AUTOSAR™ is licensed by AUTOSAR development partnership. Bluetooth™ of Bluetooth SIG Inc. CAT-iq™ of DECT Forum. COLOSSUS™, FirstGPS™ of Trimble Navigation Ltd. EMV™ of EMVCo, LLC (Visa Holdings Inc.). EPCOS™ of Epcos AG. FLEXGO™ of Microsoft Corporation. FlexRay™ is licensed by FlexRay Consortium. HYPERTERMINAL™ of Hilgraeve Incorporated. IEC™ of Commission Electrotechnique Internationale. IrDA™ of Infrared Data Association Corporation. ISO™ of INTERNATIONAL ORGANIZATION FOR STANDARDIZATION. MATLAB™ of MathWorks, Inc. MAXIM™ of Maxim Integrated Products, Inc. MICROTEC™, NUCLEUS™ of Mentor Graphics Corporation. Mifare™ of NXP. MIPI™ of MIPI Alliance, Inc. MIPS™ of MIPS Technologies, Inc., USA. muRata™ of MURATA MANUFACTURING CO., MICROWAVE OFFICE™ (MWO) of Applied Wave Research Inc., OmniVision™ of OmniVision Technologies, Inc. Openwave™ Openwave Systems Inc. RED HAT™ Red Hat, Inc. RFMD™ RF Micro Devices, Inc. SIRIUS™ of Sirius Satellite Radio Inc. SOLARIS™ of Sun Microsystems, Inc. SPANSION™ of Spansion LLC Ltd. Symbian™ of Symbian Software Limited. TAIYO YUDEN™ of Taiyo Yuden Co. TEAKLITE™ of CEVA, Inc. TEKTRONIX™ of Tektronix Inc. TOKO™ of TOKO KABUSHIKI KAISHA TA. UNIX™ of X/Open Company Limited. VERILOG™, PALLADIUM™ of Cadence Design Systems, Inc. VLYNQ™ of Texas Instruments Incorporated. VXWORKS™, WIND RIVER™ of WIND RIVER SYSTEMS, INC. ZETEX™ of Diodes Zetex Limited.

Last Trademarks Update 2010-10-26

## Table of Contents

	<b>Table of Contents</b> .....	4
	<b>List of Figures</b> .....	5
	<b>List of Tables</b> .....	6
<b>1</b>	<b>Features</b> .....	7
<b>2</b>	<b>Electrical Characteristics</b> .....	9
2.1	Absolute Maximum Ratings .....	9
2.2	Thermal Resistance .....	9
2.3	ESD Integrity .....	9
2.4	DC Characteristics .....	10
2.5	Band Select / Gain Control Truth Table .....	10
2.6	Supply Current Characteristics; $T_A = 25\text{ }^\circ\text{C}$ .....	11
2.7	Logic Signal Characteristics; $T_A = 25\text{ }^\circ\text{C}$ .....	12
2.8	Switching Times .....	12
2.9	Measured RF Characteristics UMTS Bands 12 / 17 .....	13
2.10	Measured RF Characteristics UMTS Bands 13 / 14 .....	14
2.11	Measured RF Characteristics UMTS Band 20 .....	15
2.12	Measured RF Characteristics UMTS Bands 5 / 6 .....	16
2.13	Measured RF Characteristics UMTS Band 8 .....	17
2.14	Measured RF Characteristics UMTS Bands 3 / 9 .....	18
2.15	Measured RF Characteristics UMTS Band 2 .....	19
2.16	Measured RF Characteristics UMTS Bands 1 / 4 / 10 .....	20
2.17	Measured RF Characteristics UMTS Band 40 .....	21
2.18	Measured RF Characteristics UMTS Band 38 .....	22
2.19	Measured RF Characteristics UMTS Band 7 .....	23
<b>3</b>	<b>Application Circuit and Block Diagram</b> .....	24
3.1	UMTS Bands 1, 2, 4, 5, 6 and 10 Application Circuit Schematic .....	24
3.2	UMTS Bands 3, 7, 8, 9 and 38 Application Circuit Schematic .....	25
3.3	UMTS Bands 2, 12, 13, 14, 17 and 40 Application Circuit Schematic .....	26
3.4	UMTS Bands 1, 2, 4, 10 and 20 Application Circuit Schematic .....	27
3.5	Pin Description .....	28
3.6	Application Board .....	29
<b>4</b>	<b>Physical Characteristics</b> .....	31
4.1	Package Footprint .....	31
4.2	Package Dimensions .....	32

## List of Figures

Figure 1	Block Diagram of Tri-Band LNA . . . . .	8
Figure 2	Application Circuit with Chip Outline (Top View) . . . . .	24
Figure 3	Application Circuit with Chip Outline (Top View) . . . . .	25
Figure 4	Application Circuit with Chip Outline (Top View) . . . . .	26
Figure 5	Application Circuit with Chip Outline (Top View) . . . . .	27
Figure 6	Application Board Layout on 3-layer FR4 . . . . .	29
Figure 7	Cross-Section View of Application Board . . . . .	29
Figure 8	Detail of Application Board Layout . . . . .	30
Figure 9	Recommended Footprint and Stencil Layout for the TSNP-16-1 Package . . . . .	31
Figure 10	Package Outline (Top, Side and Bottom View) . . . . .	32

## List of Tables

Table 1	Absolute Maximum Ratings .....	9
Table 2	Thermal Resistance .....	9
Table 3	ESD Integrity .....	9
Table 4	DC Characteristics, $T_A = -30 \dots 85 \text{ }^\circ\text{C}$ .....	10
Table 5	Band Select Truth Table, $V_{CC} = 2.8 \text{ V}$ .....	10
Table 6	Gain Control Truth Table, $V_{CC} = 2.8 \text{ V}$ .....	10
Table 7	Typical Switching Times; $T_A = -30 \dots 85 \text{ }^\circ\text{C}$ .....	12
Table 8	Typical Characteristics 700 MHz Band, $T_A = 25 \text{ }^\circ\text{C}$ , $V_{CC} = 2.8 \text{ V}$ .....	13
Table 9	Typical Characteristics 700 MHz Band, $T_A = 25 \text{ }^\circ\text{C}$ , $V_{CC} = 2.8 \text{ V}$ .....	14
Table 10	Typical Characteristics 800 MHz Band, $T_A = 25 \text{ }^\circ\text{C}$ , $V_{CC} = 2.8 \text{ V}$ .....	15
Table 11	Typical Characteristics 800 MHz Band, $T_A = 25 \text{ }^\circ\text{C}$ , $V_{CC} = 2.8 \text{ V}$ .....	16
Table 12	Typical Characteristics 900 MHz Band, $T_A = 25 \text{ }^\circ\text{C}$ , $V_{CC} = 2.8 \text{ V}$ .....	17
Table 13	Typical Characteristics 1800 MHz Band, $T_A = 25 \text{ }^\circ\text{C}$ , $V_{CC} = 2.8 \text{ V}$ .....	18
Table 14	Typical Characteristics 1900 MHz Band, $T_A = 25 \text{ }^\circ\text{C}$ , $V_{CC} = 2.8 \text{ V}$ .....	19
Table 15	Typical Characteristics 2100 MHz Band, $T_A = 25 \text{ }^\circ\text{C}$ , $V_{CC} = 2.8 \text{ V}$ .....	20
Table 16	Typical Characteristics 2300 MHz Band, $T_A = 25 \text{ }^\circ\text{C}$ , $V_{CC} = 2.8 \text{ V}$ .....	21
Table 17	Typical Characteristics 2600 MHz Band, $T_A = 25 \text{ }^\circ\text{C}$ , $V_{CC} = 2.8 \text{ V}$ .....	22
Table 18	Typical Characteristics 2600 MHz Band, $T_A = 25 \text{ }^\circ\text{C}$ , $V_{CC} = 2.8 \text{ V}$ .....	23
Table 19	Bill of Materials .....	24
Table 20	Bill of Materials .....	25
Table 21	Bill of Materials .....	26
Table 22	Bill of Materials .....	27
Table 23	Pin Definition and Function .....	28



## 1 Features

Main features:

- Gain: 16 (17) / -7.5 dB in high / low gain mode (all bands)
- Noise figure: 1.1 / 1.1 / 1.1 dB in high gain mode (800 MHz / 1900 MHz / 2100 MHz)
- Supply current: 3.4 (4.0) / 0.65 mA in high / low gain mode (all bands)
- Standby mode (< 2  $\mu$ A typ.)
- Output internally matched to 50  $\Omega$
- Inputs pre-matched to 50  $\Omega$
- 2kV HBM ESD protection
- Low external component count
- Small leadless TSNP-16-1 package (2.3 x 2.3 x 0.39 mm)
- Pb-free (RoHS compliant) package

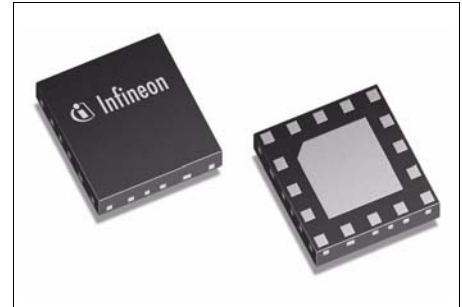

### Description

The BGA735N16 is a highly flexible, high linearity tri-band (2600/2300/2100, 1900/1800, 900/800/700 MHz) low noise amplifier MMIC for worldwide use. Based on Infineon's proprietary and cost-effective SiGe:C technology, the BGA735N16 uses an advanced biasing concept in order to achieve high linearity.

The device features dynamic gain control, temperature stabilization, standby mode, and 2 kV ESD protection on-chip as well as matching off chip. Because the matching is off chip, different LTE/UMTS bands can be easily applied. For example, the 1900 MHz path can be converted into a 2100 MHz path and vice versa by optimizing the input and output matching network.

*Note: LTE/UMTS bands 1/ 2/ 5 is the standard band combination for this product requiring no external output matching network.*

Product Name	Package	Chip	Marking
BGA735N16	TSNP-16-1	T1530	BGA735

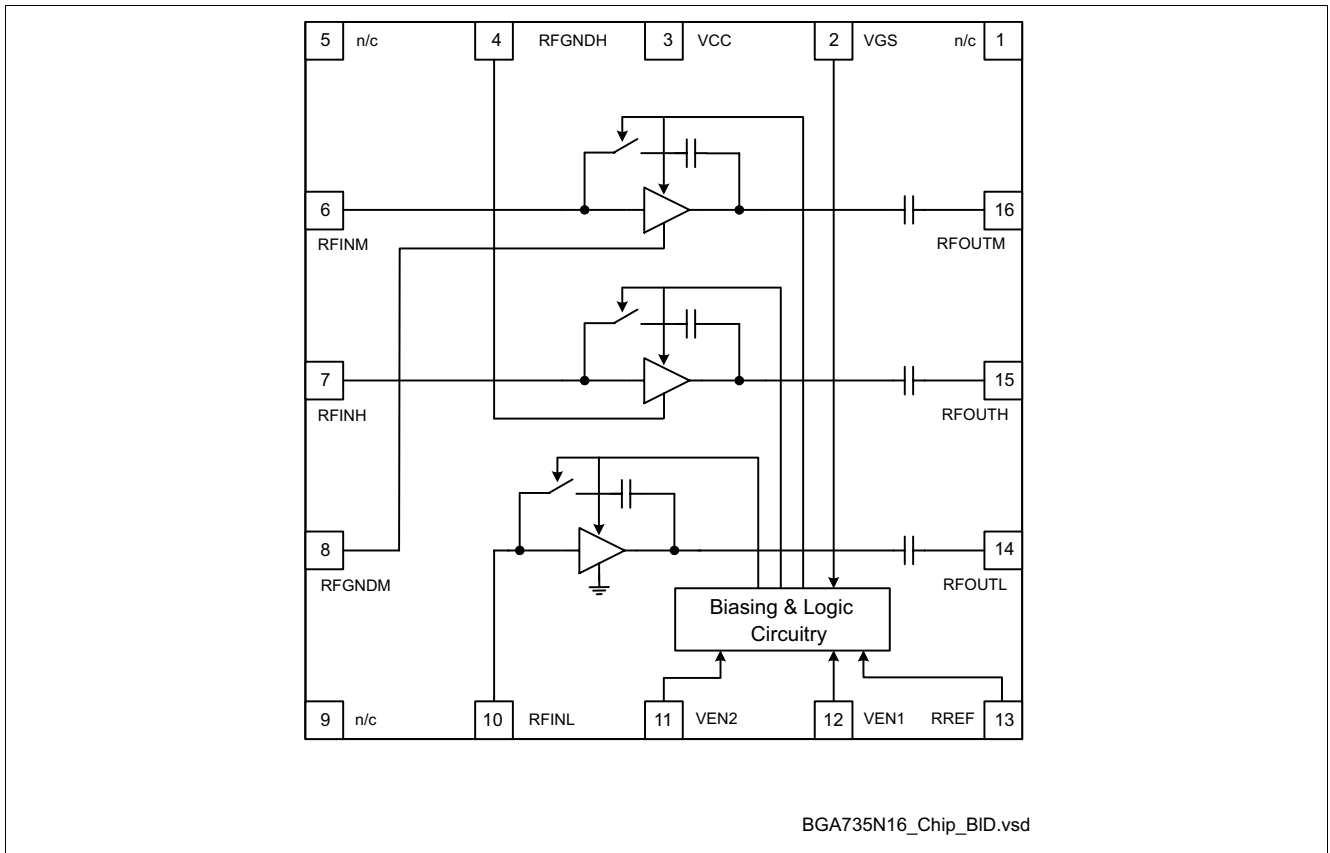

**Figure 1** Block Diagram of Tri-Band LNA



## 2 Electrical Characteristics

### 2.1 Absolute Maximum Ratings

**Table 1 Absolute Maximum Ratings**

Parameter	Symbol	Values			Unit	Note / Test Condition
		Min.	Typ.	Max.		
Supply voltage	$V_{CC}$	-0.3	–	3.6	V	–
Supply current	$I_{CC}$	–	–	10	mA	–
Pin voltage	$V_{PIN}$	-0.3	–	$V_{CC}+0.3$	V	All pins except RF input pins.
Pin voltage RF Input Pins	$V_{RFIN}$	-0.3	–	0.9	V	–
RF input power	$P_{RFIN}$	–	–	4	dBm	–
Junction temperature	$T_j$	–	–	150	°C	–
Ambient temperature range	$T_A$	-30	–	85	°C	–
Storage temperature range	$T_{stg}$	-65	–	150	°C	–

**Attention: Stresses above the max. values listed here may cause permanent damage to the device. Exposure to absolute maximum rating conditions for extended periods may affect device reliability. Maximum ratings are absolute ratings; exceeding only one of these values may cause irreversible damage to the integrated circuit.**

### 2.2 Thermal Resistance

**Table 2 Thermal Resistance**

Parameter	Symbol	Values			Unit	Note / Test Condition
		Min.	Typ.	Max.		
Thermal resistance junction to soldering point	$R_{thJS}$	–	–	≤ 37	K/W	–

### 2.3 ESD Integrity

**Table 3 ESD Integrity**

Parameter	Symbol	Values			Unit	Note / Test Condition
		Min.	Typ.	Max.		
ESD hardness HBM <sup>1)</sup>	$V_{ESD-HBM}$	–	2000	–	V	All pins

1) According to JESD22-A114

## 2.4 DC Characteristics

**Table 4 DC Characteristics,  $T_A = -30 \dots 85 \text{ }^\circ\text{C}$**

Parameter	Symbol	Values			Unit	Note / Test Condition
		Min.	Typ.	Max.		
Supply voltage	$V_{CC}$	2.6	2.8	3.0	V	–
Supply current high gain mode	$I_{CCHG}$	–	4.0 3.4	–	mA	High band Mid and low band
Supply current low gain mode	$I_{CCLG}$	–	650	–	$\mu\text{A}$	All bands
Supply current standby mode	$I_{CCOFF}$	–	0.1	2.0	$\mu\text{A}$	–
Logic level high	$V_{HI}$	1.5	2.8	–	V	VEN1, VEN2 and VGS
Logic level low	$V_{LO}$	–	0.0	0.5	V	
Logic currents VEN	$I_{ENL}$	–	0.1	–	$\mu\text{A}$	VEN1 and VEN2
	$I_{ENH}$	–	10.0	–	$\mu\text{A}$	
Logic currents VGS	$I_{GSL}$	–	0.1	–	$\mu\text{A}$	VGS
	$I_{GSH}$	–	5.0	–	$\mu\text{A}$	

## 2.5 Band Select / Gain Control Truth Table

**Table 5 Band Select Truth Table,  $V_{CC} = 2.8 \text{ V}$**

	High band	Mid band	Low band	Power Down
VEN1	H	H	L	L
VEN2	H	L	H	L

**Table 6 Gain Control Truth Table,  $V_{CC} = 2.8 \text{ V}$**

	High Gain	Low Gain
VGS	H	L

## 2.6 Supply Current Characteristics; $T_A = 25\text{ }^\circ\text{C}$

Supply current high gain mode versus resistance of reference resistor  $R_{REF}$  (see Figure 2 on Page 24; low gain mode supply current is independent of reference resistor).

**Supply Current Highband**  $I_{CC} = f(R_{REF})$   
 $V_{CC} = 2.8\text{ V}$

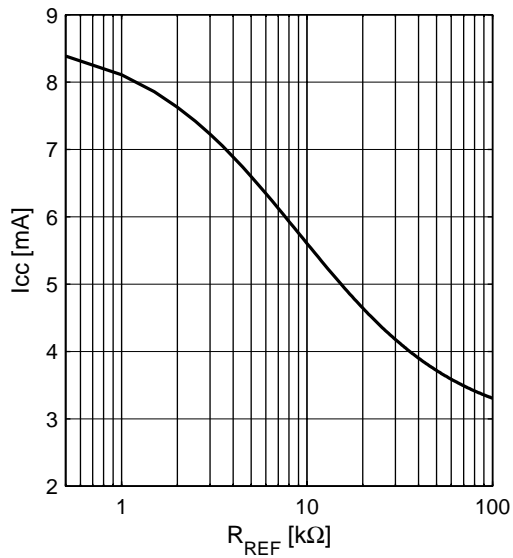

**Supply Current Midband**  $I_{CC} = f(R_{REF})$   
 $V_{CC} = 2.8\text{ V}$

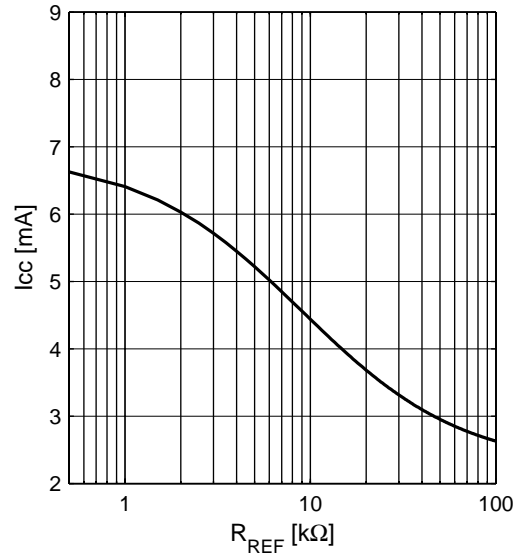

**Supply Current Lowband**  $I_{CC} = f(R_{REF})$   
 $V_{CC} = 2.8\text{ V}$

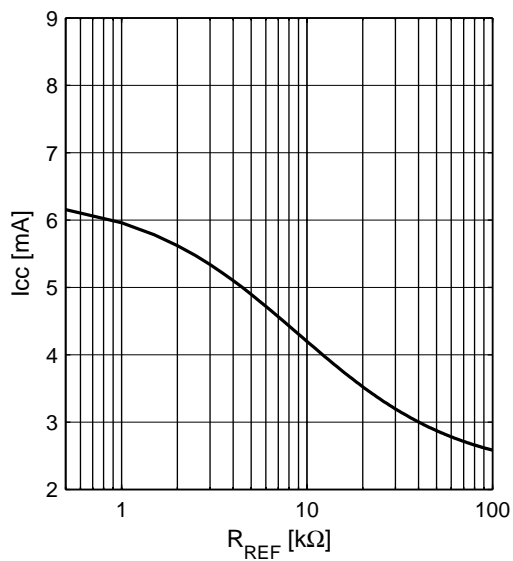

## 2.7 Logic Signal Characteristics; $T_A = 25\text{ °C}$

Current consumption of logic inputs VEN1, VEN2, VGS

**Logic currents**  $I_{EN1,2} = f(V_{EN1,2})$   
 $V_{CC} = 2.8\text{ V}$

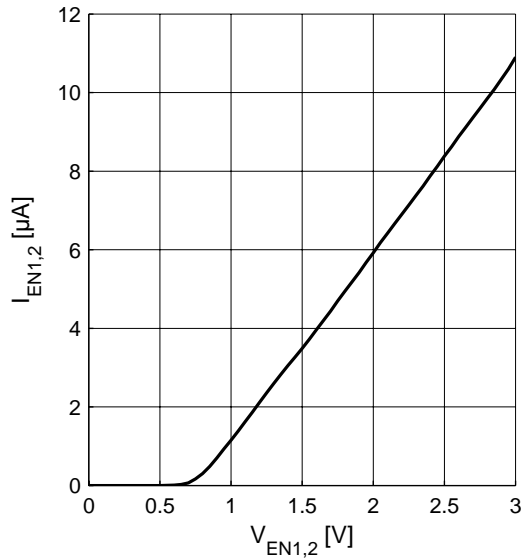

**Logic currents**  $I_{GS} = f(V_{GS})$   
 $V_{CC} = 2.8\text{ V}$

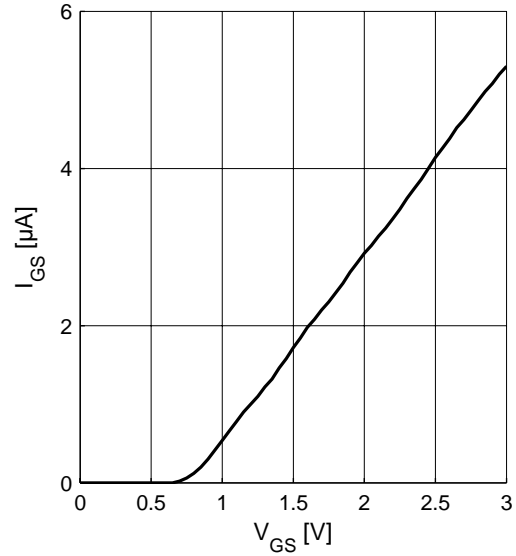

## 2.8 Switching Times

**Table 7** Typical Switching Times;  $T_A = -30 \dots 85\text{ °C}$

Parameter	Symbol	Values			Unit	Note / Test Condition
		Min.	Typ.	Max.		
Gainstep settling time	$t_{GS}$	–	1	–	µs	Switching LG ↔ HG all bands
Bandselect settling time	$t_{BS}$	–	1	–	µs	Switching from any band to a different band (pins VEN1,2)

## 2.9 Measured RF Characteristics UMTS Bands 12 / 17

**Table 8** Typical Characteristics 700 MHz Band,  $T_A = 25\text{ °C}$ ,  $V_{CC} = 2.8\text{ V}^{1)}$

Parameter	Symbol	Values			Unit	Note / Test Condition
		Min.	Typ.	Max.		
Pass band range band 12		728	–	746	MHz	–
Pass band range band 17		734	–	746	MHz	–
Current consumption	$I_{CCHG}$	–	3.4	–	mA	High gain mode
	$I_{CCLG}$	–	0.65	–	mA	Low gain mode
Gain	$S_{21HG}$	–	15.2	–	dB	High gain mode
	$S_{21LG}$	–	-9.2	–	dB	Low gain mode
Reverse Isolation <sup>2)</sup>	$S_{12HG}$	–	-39	–	dB	High gain mode
	$S_{12LG}$	–	-9.2	–	dB	Low gain mode
Noise figure	$NF_{HG}$	–	1.1	–	dB	High gain mode
	$NF_{LG}$	–	9.2	–	dB	Low gain mode
Input return loss <sup>2)</sup>	$S_{11HG}$	–	-15	–	dB	50 $\Omega$ , high gain mode
	$S_{11LG}$	–	-16	–	dB	50 $\Omega$ , low gain mode
Output return loss <sup>2)</sup>	$S_{22HG}$	–	-19	–	dB	50 $\Omega$ , high gain mode
	$S_{22LG}$	–	-12	–	dB	50 $\Omega$ , low gain mode
Stability factor <sup>3)</sup>	$k$	–	>2.3	–		DC to 8 GHz; all gain modes
Input compression point <sup>2)</sup>	$IP_{1dBHG}$	–	-6	–	dBm	High gain mode
	$IP_{1dB LG}$	–	-10	–	dBm	Low gain mode
Inband IIP3 <sup>2)</sup> $f_1 - f_2 = 1\text{ MHz}$	$IIP3_{HG}$	–	-11	–	dBm	High gain mode
	$IIP3_{LG}$	–	-1	–	dBm	Low gain mode

1) Performance based on application circuit in Figure 4 on Page 26

2) Verification based on AQL; random production test.

3) Guaranteed by device design; not tested in production.

## 2.10 Measured RF Characteristics UMTS Bands 13 / 14

**Table 9** Typical Characteristics 700 MHz Band,  $T_A = 25\text{ °C}$ ,  $V_{CC} = 2.8\text{ V}^{1)}$

Parameter	Symbol	Values			Unit	Note / Test Condition
		Min.	Typ.	Max.		
Pass band range band 13		746	–	756	MHz	–
Pass band range band 14		758	–	768	MHz	–
Current consumption	$I_{CCHG}$	–	3.4	–	mA	High gain mode
	$I_{CCLG}$	–	0.65	–	mA	Low gain mode
Gain	$S_{21HG}$	–	15.3	–	dB	High gain mode
	$S_{21LG}$	–	-8.9	–	dB	Low gain mode
Reverse Isolation <sup>2)</sup>	$S_{12HG}$	–	-39	–	dB	High gain mode
	$S_{12LG}$	–	-8.9	–	dB	Low gain mode
Noise figure	$NF_{HG}$	–	1.1	–	dB	High gain mode
	$NF_{LG}$	–	8.9	–	dB	Low gain mode
Input return loss <sup>2)</sup>	$S_{11HG}$	–	-15	–	dB	50 $\Omega$ , high gain mode
	$S_{11LG}$	–	-13	–	dB	50 $\Omega$ , low gain mode
Output return loss <sup>2)</sup>	$S_{22HG}$	–	-20	–	dB	50 $\Omega$ , high gain mode
	$S_{22LG}$	–	-14	–	dB	50 $\Omega$ , low gain mode
Stability factor <sup>3)</sup>	$k$	–	>2.3	–		DC to 8 GHz; all gain modes
Input compression point <sup>2)</sup>	$IP_{1dBHG}$	–	-6	–	dBm	High gain mode
	$IP_{1dB LG}$	–	-10	–	dBm	Low gain mode
Inband IIP3 <sup>2)</sup> $f_1 - f_2 = 1\text{ MHz}$	$IIP3_{HG}$	–	-11	–	dBm	High gain mode
	$IIP3_{LG}$	–	-1	–		Low gain mode

1) Performance based on application circuit in Figure 4 on Page 26

2) Verification based on AQL; random production test.

3) Guaranteed by device design; not tested in production.

## 2.11 Measured RF Characteristics UMTS Band 20

**Table 10** Typical Characteristics 800 MHz Band,  $T_A = 25\text{ °C}$ ,  $V_{CC} = 2.8\text{ V}^{1)}$

Parameter	Symbol	Values			Unit	Note / Test Condition
		Min.	Typ.	Max.		
Pass band range band 20		791	–	821	MHz	–
Current consumption	$I_{CCHG}$	–	3.4	–	mA	High gain mode
	$I_{CCLG}$	–	0.65	–	mA	Low gain mode
Gain	$S_{21HG}$	–	15.3	–	dB	High gain mode
	$S_{21LG}$	–	-7.8	–	dB	Low gain mode
Reverse Isolation <sup>2)</sup>	$S_{12HG}$	–	-38	–	dB	High gain mode
	$S_{12LG}$	–	-7.8	–	dB	Low gain mode
Noise figure	$NF_{HG}$	–	1.2	–	dB	High gain mode
	$NF_{LG}$	–	7.8	–	dB	Low gain mode
Input return loss <sup>2)</sup>	$S_{11HG}$	–	-14	–	dB	50 $\Omega$ , high gain mode
	$S_{11LG}$	–	-15	–	dB	50 $\Omega$ , low gain mode
Output return loss <sup>2)</sup>	$S_{22HG}$	–	-13	–	dB	50 $\Omega$ , high gain mode
	$S_{22LG}$	–	-20	–	dB	50 $\Omega$ , low gain mode
Stability factor <sup>3)</sup>	$k$	–	>2.3	–		DC to 8 GHz; all gain modes
Input compression point <sup>2)</sup>	$IP_{1dBHG}$	–	-6	–	dBm	High gain mode
	$IP_{1dBLG}$	–	-10	–	dBm	Low gain mode
Inband IIP3 <sup>2)</sup> $f_1 - f_2 = 1\text{ MHz}$	$IIP3_{HG}$	–	-10	–	dBm	High gain mode
	$IIP3_{LG}$	–	1	–	dBm	Low gain mode

1) Performance based on application circuit in Figure 5 on Page 27

2) Verification based on AQL; random production test.

3) Guaranteed by device design; not tested in production.



## 2.12 Measured RF Characteristics UMTS Bands 5 / 6

**Table 11 Typical Characteristics 800 MHz Band,  $T_A = 25\text{ °C}$ ,  $V_{CC} = 2.8\text{ V}^{1)}$**

Parameter	Symbol	Values			Unit	Note / Test Condition
		Min.	Typ.	Max.		
Pass band range band 5		869	–	894	MHz	–
Pass band range band 6		875	–	885	MHz	–
Current consumption	$I_{CCHG}$	–	3.4	–	mA	High gain mode
	$I_{CCLG}$	–	0.65	–	mA	Low gain mode
Gain	$S_{21HG}$	–	16.0	–	dB	High gain mode
	$S_{21LG}$	–	-7.5	–	dB	Low gain mode
Reverse Isolation <sup>2)</sup>	$S_{12HG}$	–	-36	–	dB	High gain mode
	$S_{12LG}$	–	-7.5	–	dB	Low gain mode
Noise figure	$NF_{HG}$	–	1.1	–	dB	High gain mode
	$NF_{LG}$	–	7.5	–	dB	Low gain mode
Input return loss <sup>2)</sup>	$S_{11HG}$	–	-16	–	dB	50 $\Omega$ , high gain mode
	$S_{11LG}$	–	-17	–	dB	50 $\Omega$ , low gain mode
Output return loss <sup>2)</sup>	$S_{22HG}$	–	-17	–	dB	50 $\Omega$ , high gain mode
	$S_{22LG}$	–	-13	–	dB	50 $\Omega$ , low gain mode
Stability factor <sup>3)</sup>	$k$	–	>2.3	–		DC to 8 GHz; all gain modes
Input compression point <sup>2)</sup>	$IP_{1dBHG}$	–	-6	–	dBm	High gain mode
	$IP_{1dB LG}$	–	-8	–	dBm	Low gain mode
Inband IIP3 <sup>2)</sup> $f_1 - f_2 = 1\text{ MHz}$	$IIP3_{HG}$	–	-7	–	dBm	High gain mode
	$IIP3_{LG}$	–	2	–		Low gain mode

1) Performance based on application circuit in Figure 2 on Page 24

2) Verification based on AQL; random production test.

3) Guaranteed by device design; not tested in production.

## 2.13 Measured RF Characteristics UMTS Band 8

**Table 12 Typical Characteristics 900 MHz Band,  $T_A = 25\text{ °C}$ ,  $V_{CC} = 2.8\text{ V}^{1)}$**

Parameter	Symbol	Values			Unit	Note / Test Condition
		Min.	Typ.	Max.		
Pass band range band 8		925	–	960	MHz	–
Current consumption	$I_{CCHG}$	–	3.4	–	mA	High gain mode
	$I_{CCLG}$	–	0.65	–	mA	Low gain mode
Gain	$S_{21HG}$	–	16.1	–	dB	High gain mode
	$S_{21LG}$	–	-7.1	–	dB	Low gain mode
Reverse Isolation <sup>2)</sup>	$S_{12HG}$	–	-36	–	dB	High gain mode
	$S_{12LG}$	–	-7.1	–	dB	Low gain mode
Noise figure	$NF_{HG}$	–	1.1	–	dB	High gain mode
	$NF_{LG}$	–	7.1	–	dB	Low gain mode
Input return loss <sup>2)</sup>	$S_{11HG}$	–	-16	–	dB	50 $\Omega$ , high gain mode
	$S_{11LG}$	–	-15	–	dB	50 $\Omega$ , low gain mode
Output return loss <sup>2)</sup>	$S_{22HG}$	–	-15	–	dB	50 $\Omega$ , high gain mode
	$S_{22LG}$	–	-16	–	dB	50 $\Omega$ , low gain mode
Stability factor <sup>3)</sup>	$k$	–	>2.3	–		DC to 8 GHz; all gain modes
Input compression point <sup>2)</sup>	$IP_{1dBHG}$	–	-5	–	dBm	High gain mode
	$IP_{1dBLG}$	–	-8	–	dBm	Low gain mode
Inband IIP3 <sup>2)</sup> $f_1 - f_2 = 1\text{ MHz}$	$IIP3_{HG}$	–	-6	–	dBm	High gain mode
	$IIP3_{LG}$	–	2	–	dBm	Low gain mode

1) Performance based on application circuit in Figure 3 on Page 25

2) Verification based on AQL; random production test.

3) Guaranteed by device design; not tested in production.

## 2.14 Measured RF Characteristics UMTS Bands 3 / 9

**Table 13** Typical Characteristics 1800 MHz Band,  $T_A = 25\text{ °C}$ ,  $V_{CC} = 2.8\text{ V}^{1)}$

Parameter	Symbol	Values			Unit	Note / Test Condition
		Min.	Typ.	Max.		
Pass band range band 3		1805	–	1880	MHz	–
Pass band range band 9		1844.9	–	1879.9	MHz	–
Current consumption	$I_{CCHG}$	–	3.4	–	mA	High gain mode
	$I_{CCLG}$	–	0.65	–	mA	Low gain mode
Gain	$S_{21HG}$	–	16.2	–	dB	High gain mode
	$S_{21LG}$	–	-8.7	–	dB	Low gain mode
Reverse Isolation <sup>2)</sup>	$S_{12HG}$	–	-36	–	dB	High gain mode
	$S_{12LG}$	–	-8.7	–	dB	Low gain mode
Noise figure	$NF_{HG}$	–	1.1	–	dB	High gain mode
	$NF_{LG}$	–	8.7	–	dB	Low gain mode
Input return loss <sup>2)</sup>	$S_{11HG}$	–	-13	–	dB	50 $\Omega$ , high gain mode
	$S_{11LG}$	–	-14	–	dB	50 $\Omega$ , low gain mode
Output return loss <sup>2)</sup>	$S_{22HG}$	–	-19	–	dB	50 $\Omega$ , high gain mode
	$S_{22LG}$	–	-15	–	dB	50 $\Omega$ , low gain mode
Stability factor <sup>3)</sup>	$k$	–	>2.5	–		DC to 8 GHz; all gain modes
Input compression point <sup>2)</sup>	$IP_{1dBHG}$	–	-7	–	dBm	High gain mode
	$IP_{1dB LG}$	–	-6	–	dBm	Low gain mode
Inband IIP3 <sup>2)</sup> $f_1 - f_2 = 1\text{ MHz}$	$IIP3_{HG}$	–	-6	–	dBm	High gain mode
	$IIP3_{LG}$	–	3	–		Low gain mode

1) Performance based on application circuit in Figure 3 on Page 25

2) Verification based on AQL; random production test.

3) Guaranteed by device design; not tested in production.

## 2.15 Measured RF Characteristics UMTS Band 2

**Table 14** Typical Characteristics 1900 MHz Band,  $T_A = 25\text{ °C}$ ,  $V_{CC} = 2.8\text{ V}^{1)}$

Parameter	Symbol	Values			Unit	Note / Test Condition
		Min.	Typ.	Max.		
Pass band range band 2		1930	–	1990	MHz	–
Current consumption	$I_{CCHG}$	–	3.4	–	mA	High gain mode
	$I_{CCLG}$	–	0.65	–	mA	Low gain mode
Gain	$S_{21HG}$	–	16.0	–	dB	High gain mode
	$S_{21LG}$	–	-7.8	–	dB	Low gain mode
Reverse Isolation <sup>2)</sup>	$S_{12HG}$	–	-35	–	dB	High gain mode
	$S_{12LG}$	–	-7.8	–	dB	Low gain mode
Noise figure	$NF_{HG}$	–	1.1	–	dB	High gain mode
	$NF_{LG}$	–	7.8	–	dB	Low gain mode
Input return loss <sup>2)</sup>	$S_{11HG}$	–	-19	–	dB	50 $\Omega$ , high gain mode
	$S_{11LG}$	–	-18	–	dB	50 $\Omega$ , low gain mode
Output return loss <sup>2)</sup>	$S_{22HG}$	–	-20	–	dB	50 $\Omega$ , high gain mode
	$S_{22LG}$	–	-15	–	dB	50 $\Omega$ , low gain mode
Stability factor <sup>3)</sup>	$k$	–	>2.4	–		DC to 8 GHz; all gain modes
Input compression point <sup>2)</sup>	$IP_{1dBHG}$	–	-7	–	dBm	High gain mode
	$IP_{1dB LG}$	–	-7	–	dBm	Low gain mode
Inband IIP3 <sup>2)</sup> $f_1 - f_2 = 1\text{ MHz}$	$IIP3_{HG}$	–	-6	–	dBm	High gain mode
	$IIP3_{LG}$	–	3	–	dBm	Low gain mode

1) Performance based on application circuit in Figure 2 on Page 24

2) Verification based on AQL; random production test.

3) Guaranteed by device design; not tested in production.

## 2.16 Measured RF Characteristics UMTS Bands 1 / 4 / 10

**Table 15** Typical Characteristics 2100 MHz Band,  $T_A = 25\text{ °C}$ ,  $V_{CC} = 2.8\text{ V}^{1)}$

Parameter	Symbol	Values			Unit	Note / Test Condition
		Min.	Typ.	Max.		
Pass band range band 1		2110	–	2170	MHz	–
Pass band range band 4		2110	–	2155	MHz	–
Pass band range band 10		2110	–	2170	MHz	–
Current consumption	$I_{CCHG}$	–	4.0	–	mA	High gain mode
	$I_{CCLG}$	–	0.65	–	mA	Low gain mode
Gain	$S_{21HG}$	–	17.2	–	dB	High gain mode
	$S_{21LG}$	–	-7.8	–	dB	Low gain mode
Reverse Isolation <sup>2)</sup>	$S_{12HG}$	–	-35	–	dB	High gain mode
	$S_{12LG}$	–	-7.8	–	dB	Low gain mode
Noise figure	$NF_{HG}$	–	1.1	–	dB	High gain mode
	$NF_{LG}$	–	7.8	–	dB	Low gain mode
Input return loss <sup>2)</sup>	$S_{11HG}$	–	-16	–	dB	50 $\Omega$ , high gain mode
	$S_{11LG}$	–	-17	–	dB	50 $\Omega$ , low gain mode
Output return loss <sup>2)</sup>	$S_{22HG}$	–	-23	–	dB	50 $\Omega$ , high gain mode
	$S_{22LG}$	–	-12	–	dB	50 $\Omega$ , low gain mode
Stability factor <sup>3)</sup>	$k$	–	>2.3	–		DC to 8 GHz; all gain modes
Input compression point <sup>2)</sup>	$IP_{1dBHG}$	–	-10	–	dBm	High gain mode
	$IP_{1dB LG}$	–	-6	–	dBm	Low gain mode
Inband IIP3 <sup>2)</sup> $f_1 - f_2 = 1\text{ MHz}$	$IIP3_{HG}$	–	-3	–	dBm	High gain mode
	$IIP3_{LG}$	–	3	–		Low gain mode

1) Performance based on application circuit in Figure 2 on Page 24

2) Verification based on AQL; random production test.

3) Guaranteed by device design; not tested in production.

## 2.17 Measured RF Characteristics UMTS Band 40

**Table 16 Typical Characteristics 2300 MHz Band,  $T_A = 25\text{ °C}$ ,  $V_{CC} = 2.8\text{ V}^{1)}$**

Parameter	Symbol	Values			Unit	Note / Test Condition
		Min.	Typ.	Max.		
Pass band range band 40		2300	–	2400	MHz	–
Current consumption	$I_{CCHG}$	–	4.0	–	mA	High gain mode
	$I_{CCLG}$	–	0.65	–	mA	Low gain mode
Gain	$S_{21HG}$	–	17.1	–	dB	High gain mode
	$S_{21LG}$	–	7.0	–	dB	Low gain mode
Reverse Isolation <sup>2)</sup>	$S_{12HG}$	–	-33	–	dB	High gain mode
	$S_{12LG}$	–	-7.0	–	dB	Low gain mode
Noise figure	$NF_{HG}$	–	1.1	–	dB	High gain mode
	$NF_{LG}$	–	7.0	–	dB	Low gain mode
Input return loss <sup>2)</sup>	$S_{11HG}$	–	-20	–	dB	50 $\Omega$ , high gain mode
	$S_{11LG}$	–	-18	–	dB	50 $\Omega$ , low gain mode
Output return loss <sup>2)</sup>	$S_{22HG}$	–	-20	–	dB	50 $\Omega$ , high gain mode
	$S_{22LG}$	–	-11	–	dB	50 $\Omega$ , low gain mode
Stability factor <sup>3)</sup>	$k$	–	>2.0	–		DC to 8 GHz; all gain modes
Input compression point <sup>2)</sup>	$IP_{1dBHG}$	–	-10	–	dBm	High gain mode
	$IP_{1dBLG}$	–	-4	–	dBm	Low gain mode
Inband IIP3 <sup>2)</sup> $f_1 - f_2 = 1\text{ MHz}$	$IIP3_{HG}$	–	-2	–	dBm	High gain mode
	$IIP3_{LG}$	–	6	–	dBm	Low gain mode

1) Performance based on application circuit in Figure 4 on Page 26

2) Verification based on AQL; random production test.

3) Guaranteed by device design; not tested in production.

## 2.18 Measured RF Characteristics UMTS Band 38

**Table 17** Typical Characteristics 2600 MHz Band,  $T_A = 25\text{ °C}$ ,  $V_{CC} = 2.8\text{ V}^{1)}$

Parameter	Symbol	Values			Unit	Note / Test Condition
		Min.	Typ.	Max.		
Pass band range band 38		2570	–	2620	MHz	–
Current consumption	$I_{CCHG}$	–	3.4	–	mA	High gain mode
	$I_{CCLG}$	–	0.65	–	mA	Low gain mode
Gain	$S_{21HG}$	–	15.5	–	dB	High gain mode
	$S_{21LG}$	–	-6.5	–	dB	Low gain mode
Reverse Isolation <sup>2)</sup>	$S_{12HG}$	–	-33	–	dB	High gain mode
	$S_{12LG}$	–	-6.5	–	dB	Low gain mode
Noise figure	$NF_{HG}$	–	1.2	–	dB	High gain mode
	$NF_{LG}$	–	6.5	–	dB	Low gain mode
Input return loss <sup>2)</sup>	$S_{11HG}$	–	-14	–	dB	50 $\Omega$ , high gain mode
	$S_{11LG}$	–	-13	–	dB	50 $\Omega$ , low gain mode
Output return loss <sup>2)</sup>	$S_{22HG}$	–	-13	–	dB	50 $\Omega$ , high gain mode
	$S_{22LG}$	–	-13	–	dB	50 $\Omega$ , low gain mode
Stability factor <sup>3)</sup>	$k$	–	>2.0	–		DC to 8 GHz; all gain modes
Input compression point <sup>2)</sup>	$IP_{1dBHG}$	–	-7	–	dBm	High gain mode
	$IP_{1dB LG}$	–	-2	–	dBm	Low gain mode
Inband IIP3 <sup>2)</sup> $f_1 - f_2 = 1\text{ MHz}$	$IIP3_{HG}$	–	-3	–	dBm	High gain mode
	$IIP3_{LG}$	–	7	–	dBm	Low gain mode

1) Performance based on application circuit in Figure 3 on Page 25

2) Verification based on AQL; random production test.

3) Guaranteed by device design; not tested in production.



## 2.19 Measured RF Characteristics UMTS Band 7

**Table 18** Typical Characteristics 2600 MHz Band,  $T_A = 25\text{ °C}$ ,  $V_{CC} = 2.8\text{ V}^{1)}$

Parameter	Symbol	Values			Unit	Note / Test Condition
		Min.	Typ.	Max.		
Pass band range band 7		2620	–	2690	MHz	–
Current consumption	$I_{CCHG}$	–	4.0	–	mA	High gain mode
	$I_{CCLG}$	–	0.65	–	mA	Low gain mode
Gain	$S_{21HG}$	–	15.6	–	dB	High gain mode
	$S_{21LG}$	–	-6.3	–	dB	Low gain mode
Reverse Isolation <sup>2)</sup>	$S_{12HG}$	–	-32	–	dB	High gain mode
	$S_{12LG}$	–	-6.3	–	dB	Low gain mode
Noise figure	$NF_{HG}$	–	1.2	–	dB	High gain mode
	$NF_{LG}$	–	6.3	–	dB	Low gain mode
Input return loss <sup>2)</sup>	$S_{11HG}$	–	-16	–	dB	50 $\Omega$ , high gain mode
	$S_{11LG}$	–	-12	–	dB	50 $\Omega$ , low gain mode
Output return loss <sup>2)</sup>	$S_{22HG}$	–	-14	–	dB	50 $\Omega$ , high gain mode
	$S_{22LG}$	–	-13	–	dB	50 $\Omega$ , low gain mode
Stability factor <sup>3)</sup>	$k$	–	>2.0	–		DC to 8 GHz; all gain modes
Input compression point <sup>2)</sup>	$IP_{1dBHG}$	–	-7	–	dBm	High gain mode
	$IP_{1dBLG}$	–	-3	–	dBm	Low gain mode
Inband IIP3 <sup>2)</sup> $f_1 - f_2 = 1\text{ MHz}$	$IIP3_{HG}$	–	-2	–	dBm	High gain mode
	$IIP3_{LG}$	–	9	–	dBm	Low gain mode

1) Performance based on application circuit in Figure 3 on Page 25

2) Verification based on AQL; random production test.

3) Guaranteed by device design; not tested in production.

### 3 Application Circuit and Block Diagram

#### 3.1 UMTS Bands 1, 2, 4, 5, 6 and 10 Application Circuit Schematic

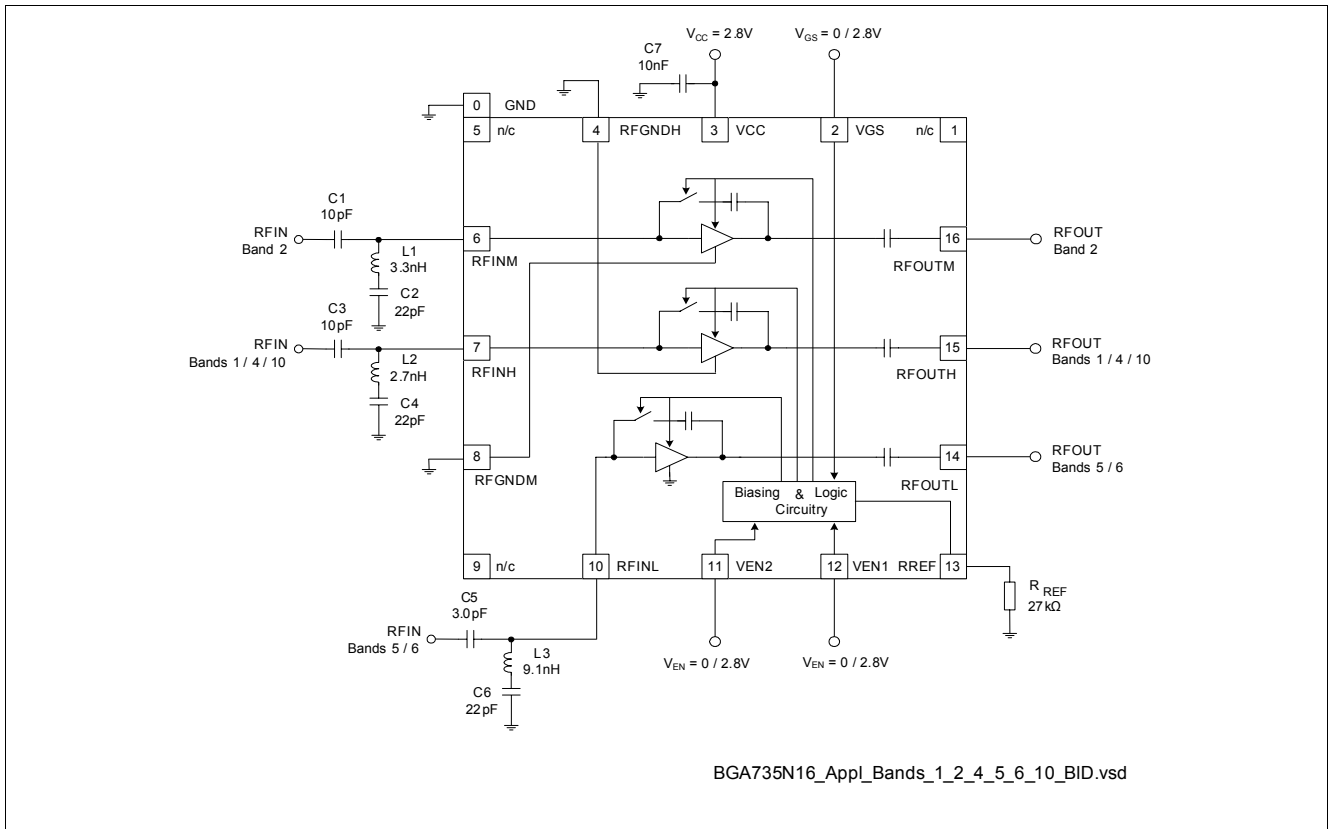

**Figure 2 Application Circuit with Chip Outline (Top View)**

Note: Package paddle (Pin 0) has to be RF grounded.

**Table 19 Bill of Materials**

Part Number	Part Type	Manufacturer	Size	Comment
L1 ... L3	Chip inductor	Various	0402	Wirewound, Q ≈ 50
C1 ... C7	Chip capacitor	Various	0402	
R <sub>REF</sub>	Chip resistor	Various	0402	

### 3.2 UMTS Bands 3, 7, 8, 9 and 38 Application Circuit Schematic

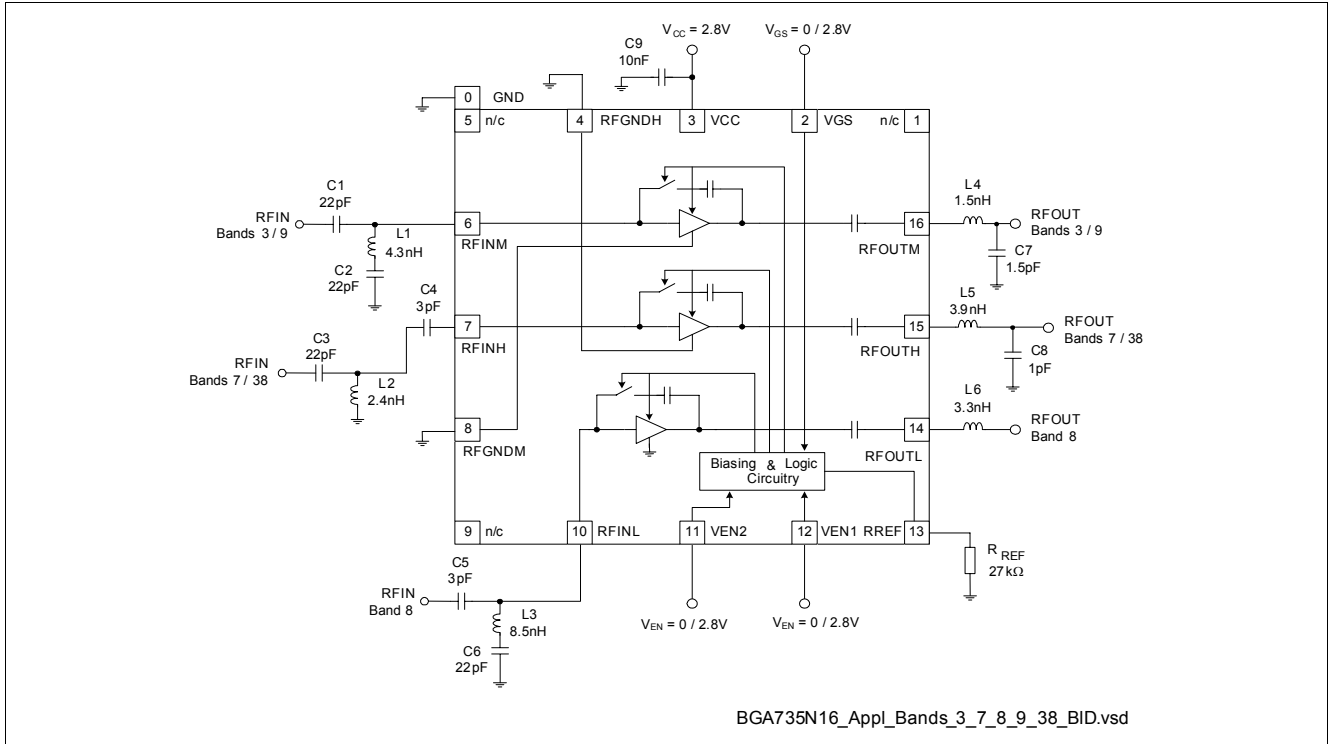

**Figure 3 Application Circuit with Chip Outline (Top View)**

*Note: Package paddle (Pin 0) has to be RF grounded.*

**Table 20 Bill of Materials**

Part Number	Part Type	Manufacturer	Size	Comment
L1 ... L6	Chip inductor	Various	0402	Wirewound, $Q \approx 50$
C1 ... C9	Chip capacitor	Various	0402	
$R_{REF}$	Chip resistor	Various	0402	

### 3.3 UMTS Bands 2, 12, 13, 14, 17 and 40 Application Circuit Schematic

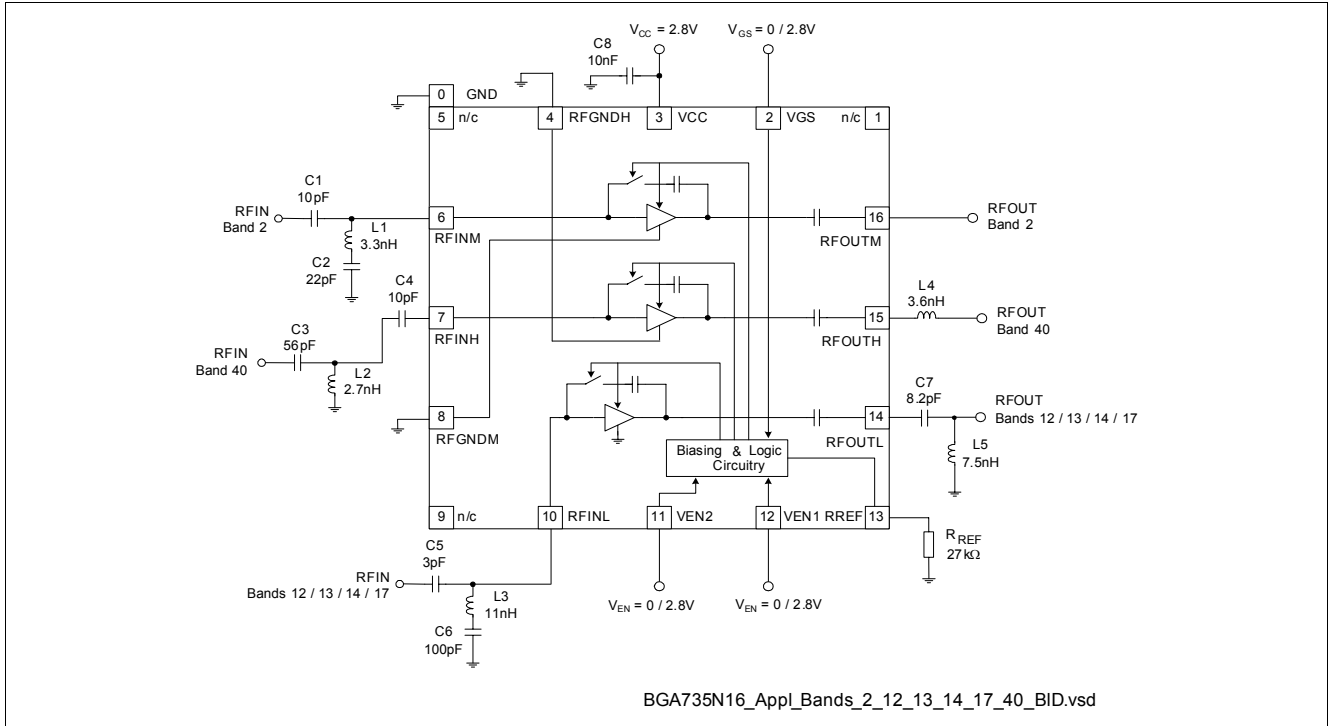

**Figure 4 Application Circuit with Chip Outline (Top View)**

*Note: Package paddle (Pin 0) has to be RF grounded.*

**Table 21 Bill of Materials**

Part Number	Part Type	Manufacturer	Size	Comment
L1 ... L5	Chip inductor	Various	0402	Wirewound, Q ≈ 50
C1 ... C8	Chip capacitor	Various	0402	
R <sub>REF</sub>	Chip resistor	Various	0402	

### 3.4 UMTS Bands 1, 2, 4, 10 and 20 Application Circuit Schematic

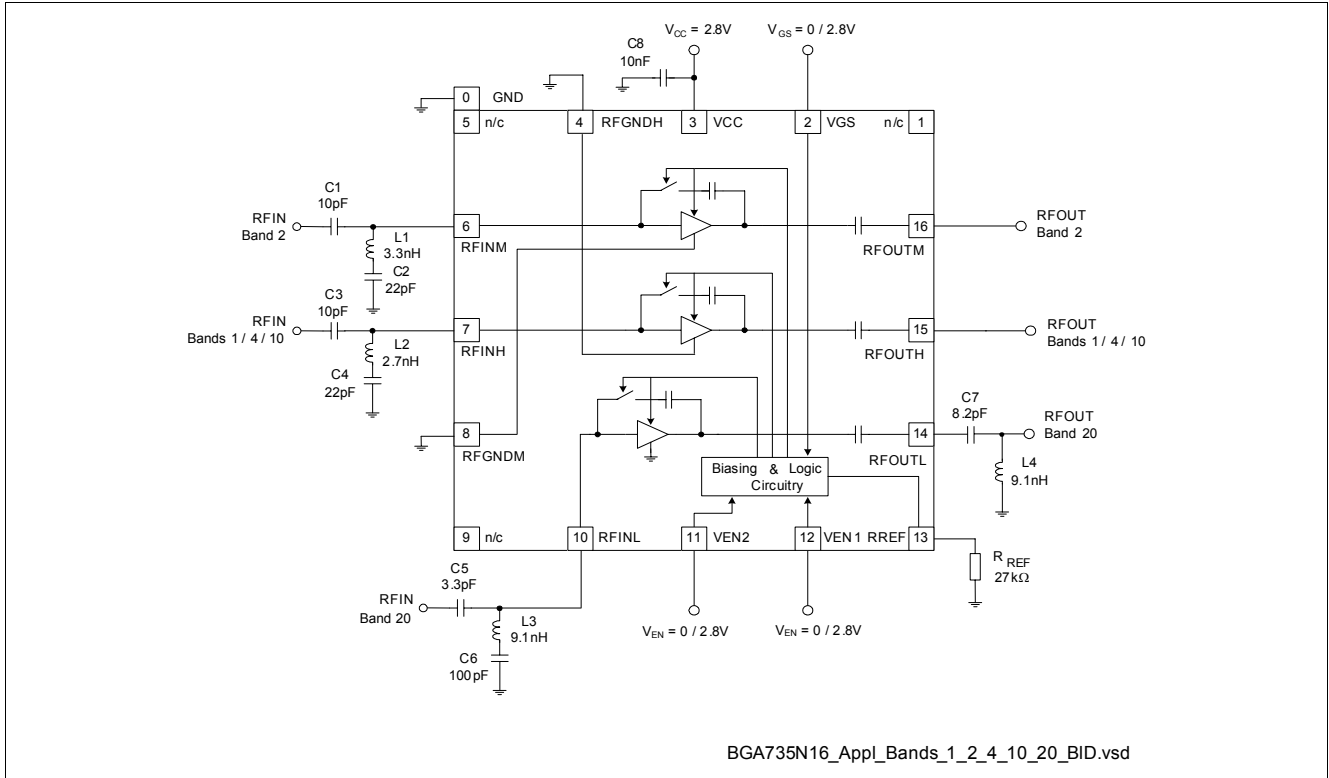

**Figure 5 Application Circuit with Chip Outline (Top View)**

*Note: Package paddle (Pin 0) has to be RF grounded.*

**Table 22 Bill of Materials**

Part Number	Part Type	Manufacturer	Size	Comment
L1 ... L4	Chip inductor	Various	0402	Wirewound, $Q \approx 50$
C1 ... C8	Chip capacitor	Various	0402	
$R_{REF}$	Chip resistor	Various	0402	

### 3.5 Pin Description

**Table 23 Pin Definition and Function**

Pin No.	Name	Pin Type	Buffer Type	Function
0	GND	–	–	Ground connection for low band LNA and control circuitry (package paddle)
1	n/c	–	–	Not connected
2	VGS	–	–	Gain step control
3	VCC	–	–	Supply voltage
4	RFGNDH	–	–	High band LNA emitter ground
5	n/c	–	–	Not connected
6	RFINM	–	–	Mid band LNA input
7	RFINH	–	–	High band LNA input
8	RFGNDM	–	–	Mid band LNA emitter ground
9	n/c	–	–	Not connected
10	RFINL	–	–	Low band LNA input
11	VEN2	–	–	Band select control
12	VEN1	–	–	Band select control
13	RREF	–	–	Bias current reference resistor (high gain mode)
14	RFOUTL	–	–	Low band output
15	RFOUTH	–	–	High band LNA output
16	RFOUTM	–	–	Mid band LNA output

### 3.6 Application Board

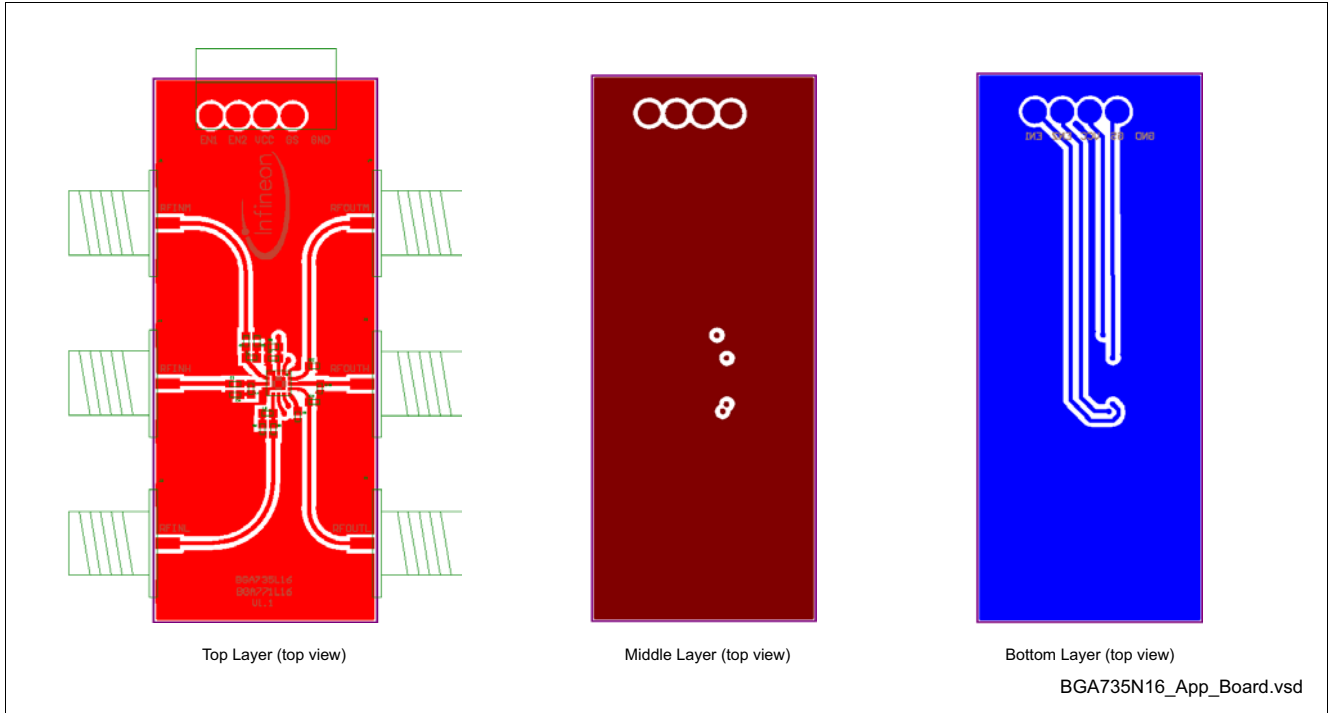

**Figure 6 Application Board Layout on 3-layer FR4**

*Note: Top layer thickness: 0.2 mm, bottom layer thickness: 0.660 mm, 17  $\mu$ m Cu metallization, gold plated. Board size: 21mm x 50 mm.*

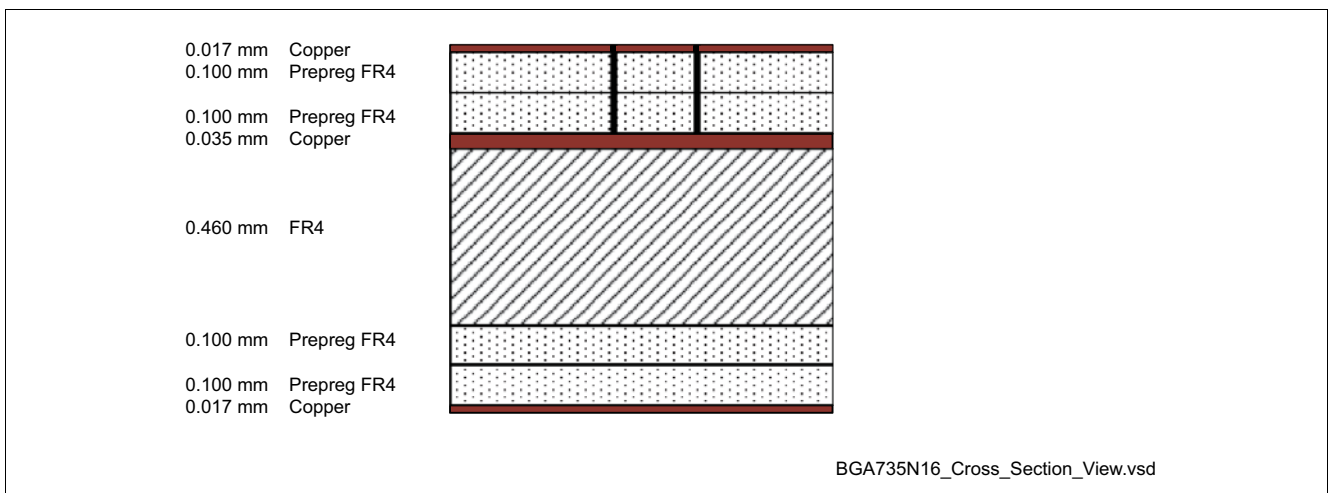

**Figure 7 Cross-Section View of Application Board**



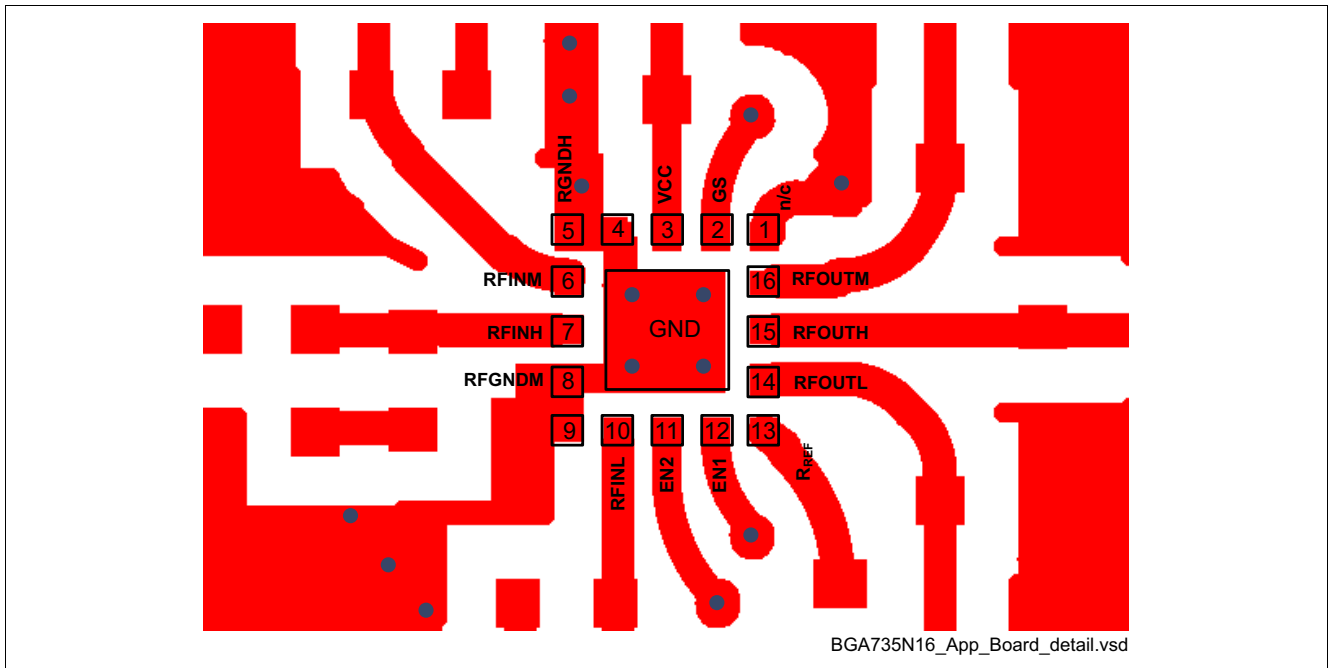

**Figure 8** Detail of Application Board Layout

*Note: In order to achieve the same performance as given in this datasheet please follow the suggested PCB-layout as closely as possible. The position of the GND via is critical for RF performance.*

## 4 Physical Characteristics

### 4.1 Package Footprint

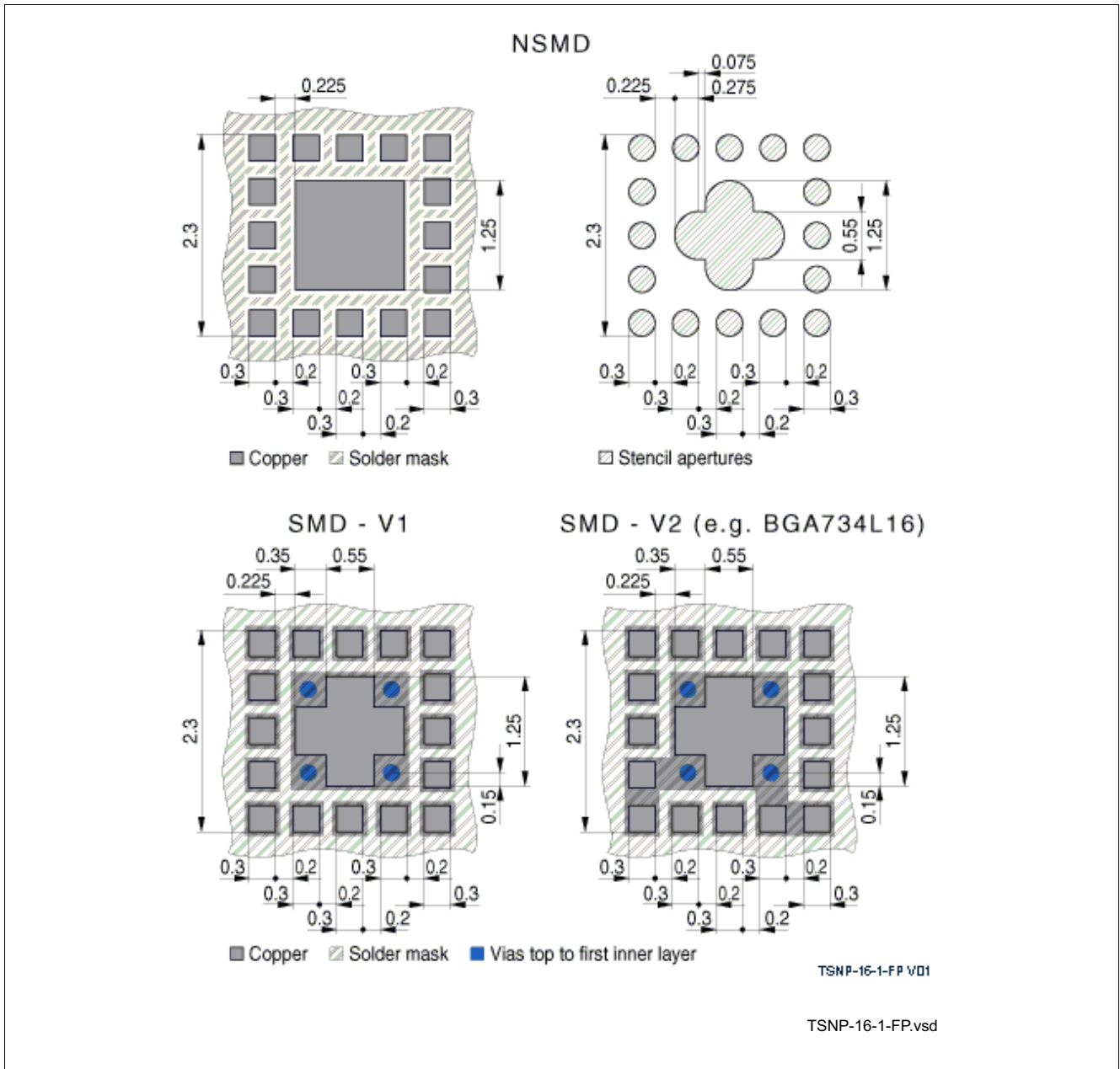
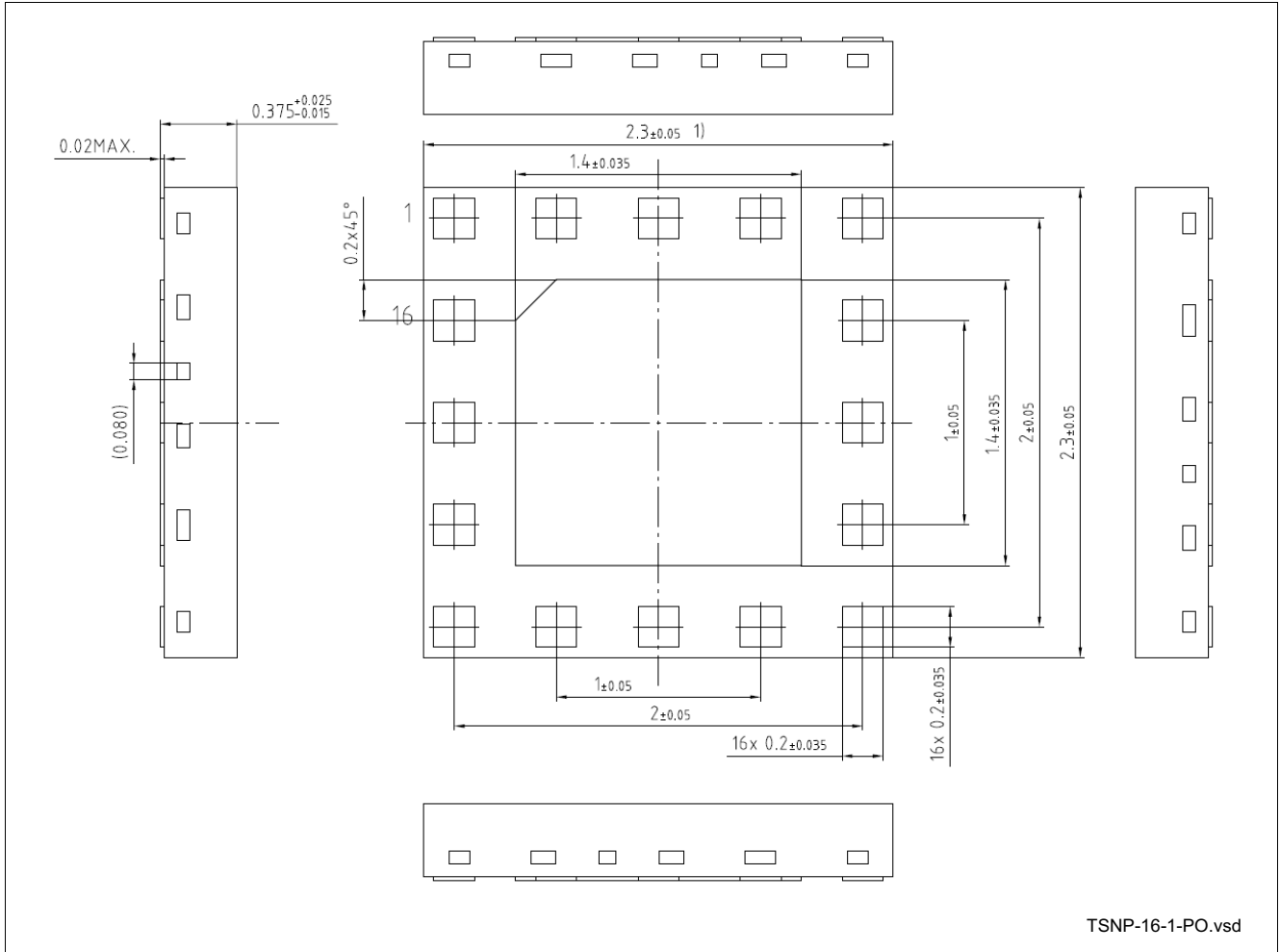

Figure 9 Recommended Footprint and Stencil Layout for the TSNP-16-1 Package

**4.2 Package Dimensions**



**Figure 10 Package Outline (Top, Side and Bottom View)**

[www.infineon.com](http://www.infineon.com)

Published by Infineon Technologies AG

## Данный компонент на территории Российской Федерации

### Вы можете приобрести в компании MosChip.

Для оперативного оформления запроса Вам необходимо перейти по данной ссылке:

<http://moschip.ru/get-element>

Вы можете разместить у нас заказ для любого Вашего проекта, будь то серийное производство или разработка единичного прибора.

В нашем ассортименте представлены ведущие мировые производители активных и пассивных электронных компонентов.

Нашей специализацией является поставка электронной компонентной базы двойного назначения, продукции таких производителей как XILINX, Intel (ex.ALTERA), Vicor, Microchip, Texas Instruments, Analog Devices, Mini-Circuits, Amphenol, Glenair.

Сотрудничество с глобальными дистрибьюторами электронных компонентов, предоставляет возможность заказывать и получать с международных складов практически любой перечень компонентов в оптимальные для Вас сроки.

На всех этапах разработки и производства наши партнеры могут получить квалифицированную поддержку опытных инженеров.

Система менеджмента качества компании отвечает требованиям в соответствии с ГОСТ Р ИСО 9001, ГОСТ РВ 0015-002 и ЭС РД 009

### Офис по работе с юридическими лицами:

105318, г.Москва, ул.Щербаковская д.3, офис 1107, 1118, ДЦ «Щербаковский»

Телефон: +7 495 668-12-70 (многоканальный)

Факс: +7 495 668-12-70 (доб.304)

E-mail: [info@moschip.ru](mailto:info@moschip.ru)

Skype отдела продаж:

moschip.ru

moschip.ru\_4

moschip.ru\_6

moschip.ru\_9