

# ELR H3-IES-PT- 24DC/500AC-...

## Hybrid motor starter

Data sheet  
105518\_en\_01

© PHOENIX CONTACT 2013-12-17



## 1 Description

The 3-phase hybrid motor starter with current monitoring provides the following functions.

- Right contactor
- Motor overload protection relay
- EMERGENCY STOP to performance level PLe

The amount of cabling required is reduced to a minimum by the internal locking circuit and the load wiring.



Make sure you always use the latest documentation.  
It can be downloaded from the product at [phoenixcontact.net/products](http://phoenixcontact.net/products).



This data sheet is valid for all products listed on the following page:

---

<b>2</b>	<b>Table of contents</b>	
1	Description .....	1
2	Table of contents .....	2
3	Ordering data .....	3
4	Technical data .....	3
5	Safety regulations and installation notes.....	6
6	Operating and indication elements .....	7
7	Connection notes .....	7
	7.1 Mains connection and line protection .....	7
	7.2 Connecting cables .....	8
	7.3 Block diagram.....	8
8	Function.....	9
	8.1 Status and diagnostics indicators.....	9
	8.2 Diagnostic function.....	9
	8.3 Parameterization - Nominal current setting .....	11
9	Application examples .....	12
	9.1 Emergency stop .....	12
	9.2 Safety door (emergency stop) .....	13
	9.3 Motor protection .....	14
	9.4 Motor with brake.....	14
	9.5 Auxiliary relay connection .....	14
10	Safety functions .....	15
	10.1 Safe shutdown .....	15
	10.2 Motor protection .....	15
11	Trigger characteristic for 20°C .....	16
12	Derating curves for 100% operating time.....	17

### 3 Ordering data

Description	Type	Order No.	Pcs. / Pkt.
"3 in 1" hybrid motor starter for starting 3~ AC motors up to 550 V AC, with 24 V DC input, 0.6 A output current, emergency stop function, adjustable overload shutdown, and push-in connection.	ELR H3-IES-PT- 24DC/500AC-0,6	2903914	1
"3 in 1" hybrid motor starter for starting 3~ AC motors up to 550 V AC, with 24 V DC input, 2.4 A output current, emergency stop function, adjustable overload shutdown, and push-in connection.	ELR H3-IES-PT- 24DC/500AC-2	2903916	1
"3 in 1" hybrid motor starter for starting 3~ AC motors up to 550 V AC, with 24 V DC input, 9 A output current, emergency stop function, adjustable overload shutdown, and push-in connection.	ELR H3-IES-PT- 24DC/500AC-9	2903918	1

### 4 Technical data

Device supply	
Rated control supply voltage $U_S$	24 V DC (According to IEC 60947-1)
Rated control supply voltage range	19.2 V DC ... 30 V DC (32 V DC, max. 1 min. )
Voltage range with reference to $U_S$	0.8 ... 1.25
Rated control supply current $I_S$	$\leq 40$ mA
Protective circuit	Protection against polarity reversal Surge protection

Control input	
Typical input current at $U_N$	$\leq 5$ mA
Rated control supply current $I_S$	$\leq 40$ mA (According to IEC 60947-1)
Rated actuating voltage $U_C$	24 V DC
Voltage range with reference to $U_C$	0.8 ... 1.25
Rated actuating current $I_C$	$\leq 5$ mA
Triggering voltage range "High"	19.2 V DC ... 30 V DC
Triggering voltage range "Low"	-3 V DC ... 9.6 V DC
Switching level "safe off"	< 5 V DC
Protective circuit	Protection against polarity reversal
Typical response time	< 35 ms
Typical turn-off time	< 40 ms

AC output	
Nominal output voltage	500 V AC ( 50 Hz , 60 Hz )
Nominal output voltage range	42 V AC ... 550 V AC
Load current see derating curve	75 mA ... max. 600 mA / 180 mA ... max. 2.4 A / 1.5 A ... max. 9 A
Rated operating current at AC-51	0.6 A / 2.4 A / 9 A
Rated operating current at AC-53a	0.6 A / 2.4 A / 6.5 A
Leakage current	0 mA / 0 mA / 0 mA
Residual voltage	at $I_e < 0.2$ V / < 0.3 V / < 0.5 V
Surge current	100 A (t = 10 ms)
Protective circuit	Surge protection Varistor

**Acknowledge output**

Confirmation 01: floating change-over contact, signal contact

Contact material	Ag alloy, hard gold-plated
Switching voltage	100 mV AC/DC ... 30 V AC / 36 V DC
Min. switching current	1 mA
Continuous load current	≤ 50 mA

**Measuring technology and display**

Measuring via Current transformer for line current on L1 and L3

**Blocking protection**

I(L1) or I(L3)	- / - / > 45 A
Response time	- / - / 2 s
Trigger characteristic in acc. with IEC 60947	Class 10A / Class 10A / Class 10A
Cooling time	20 min / 20 min / 20 min

**General data**

Service life	3 x 10 <sup>7</sup> cycles
Reversing frequency	max. 2 Hz
Mounting position	Vertical (horizontal DIN rail)
Mounting	Can be aligned with spacing = 20 mm
Operating mode	100% operating factor
Degree of protection	IP20
Test voltage input/output	4 kV <sub>rms</sub>
Power dissipation min./max.	0.88 W / 2.5 W ; 0.88 W / 4.1 W ; 0.88 W / 7 W
Dimensions W / H / D	22.5 mm / 99 mm / 114.5 mm

**Connection data**

Connection method	Push-in connection
Conductor cross section, solid	0.14 mm <sup>2</sup> ... 2.5 mm <sup>2</sup>
Conductor cross section, stranded	0.14 mm <sup>2</sup> ... 2.5 mm <sup>2</sup>
Conductor cross section [AWG]	26 ... 14
Stripping length	10 mm

**Ambient conditions**

Ambient temperature (operation)	-25 °C ... 70 °C
Ambient temperature (storage/transport)	-40 °C ... 80 °C

**Standards/regulations**

Standards	DIN EN 50178 IEC 60947-1 EN 60947-4-2 IEC 61508 ISO 13849
-----------	---

**Air and creepage distances between the power circuits**

Rated surge voltage	6 kV
Insulation	Safe isolation (EN 50178) for mains voltage ≤ 500 V AC Safe isolation (IEC 60947-1) for mains voltage ≤ 300 V AC Basic insulation (IEC 60947-1) for mains voltage of 300 ... 500 V AC
Surge voltage category	III
Pollution degree	2

**Conformance / approvals**

EU type-examination certificate	Ⓜ II (2) G [Ex e] [Ex d] [Ex px] Ⓜ II (2) D [Ex t] [Ex p] PTB 07 ATEX 3145
Safety Integrity Level according to IEC 61508	SIL 3 (safe shutdown)
Safety Integrity Level according to IEC 61508	SIL 2 (motor protection)
Category acc. to EN ISO 13849	3
Performance level according to ISO 13849	e

## 5 Safety regulations and installation notes

- When working on the device, observe the national safety and accident prevention regulations.
- Disregarding these safety regulations may result in death, serious personal injury or damage to equipment.
- Startup, mounting, modifications, and upgrades should only be carried out by a skilled electrical engineer!
- Disconnect the power to the module.
- For emergency stop applications, the machine must be prevented from restarting automatically by a higher-level control system.
- During operation, parts of electrical switching devices carry hazardous voltages.
- During operation, the protective covers must not be removed from the electric switchgear.
- Keep the product documentation in a safe place.
- The device is associated equipment and may not be installed in potentially explosive areas. When installing and operating associated equipment, the applicable safety directives must be observed.
- Observe the safety regulations that are applicable when motors are used in the Ex area (ATEX directive 94/9/EG).
- If you use the "Automatic RESET" mode, the drive is switched on again after the cooling time has expired - if a control signal is still present. The cooling time is 20 minutes. For applications in the Ex-protection area, automatic restart is not permitted.
- The equipment may not be exposed to mechanical or thermal influences that exceed the limits as described in the operating instructions. To protect the device against mechanical or electrical damage, install it in a suitable housing with appropriate degree of protection according to IEC 60529/EN 60529, if required. Where dust is present, the device must be installed in suitable housing (IP64, minimum) according to EN 50281.
- Install the device according to the instructions in the installation instructions. Access to circuits within the device is not permitted.
- The operating equipment cannot be repaired by the user and must be replaced by an equivalent device. Repairs may only be carried out by the manufacturer.
- For safety technical data, please refer to this document and certificates (EC-type examination certificate and other approvals if appropriate).
- The device executes a function diagnosis when the drive is switched on or is in the switched on state. In addition, an authorized electrician or a skilled worker who is well acquainted with the relevant standards can conduct the "Motor overload protection" safety function test. For this test, the drive must be activated and the current flow in a conductor interrupted (e.g. by removing the fuse in the L1 or L3 phase). The hybrid motor starter then switches off the drive within 1.5 to 2 s. The LED for right rotation (forward running) goes out, and the Err-LED and the reply output are set.
- The device must be secured with the help of an access protection during safety-related applications.
- Only use power supply units with safe isolation and PELV according to EN 50178 / VDE 0160 (PELV). This prevents short circuits between primary and secondary sides.
- Observe the minimum permissible load current in safety-related applications:  
ELR H3-...ES.../500AC-0,6:  $\geq 75$  mA  
ELR H3-...ES.../500AC-2:  $\geq 180$  mA  
ELR H3-...ES.../500AC-9:  $\geq 1.5$  A

### Area of application

- In circuits in potentially dust-explosive areas of zones 21 and 22, it must be guaranteed that the equipment connected to this circuit complies with category 2D or 3D or is certified as such.
- This is a product for environment A (industry). The device can cause unwanted radio interference if used in Class B environments (household). In this case, the user may be obligated to take the necessary precautionary measures.

## 6 Operating and indication elements

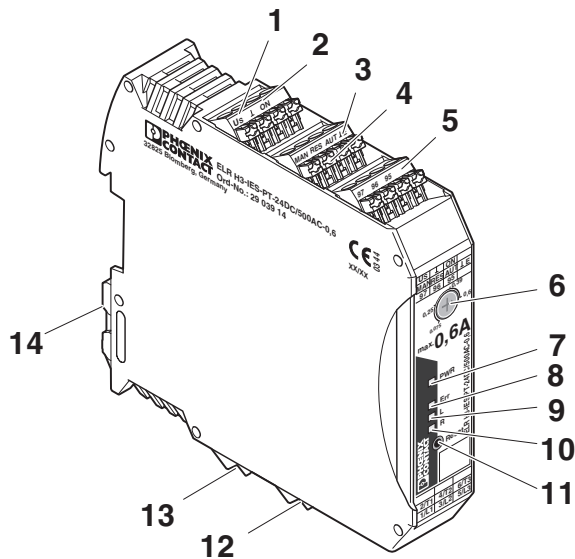

Figure 1 Operating and indication elements

- 1 Input: Control supply voltage
- 2 Control input: ON
- 3  $\perp$  E: benchmark control input
- 4 Acknowledgment inputs MAN, RES, AUT
- 5 Feedback
- 6 Potentiometer for nominal current parameterization
- 7 LED PWR: Control supply voltage
- 8 LED Err: Message/error
- 9 LED  $I_{adj}$ : Current adjustment
- 10 LED ON: Forward running
- 11 Reset button
- 12 3-phase output voltage
- 13 3-phase input voltage
- 14 Metal lock for fixing to DIN rail

## 7 Connection notes



**WARNING: Danger to life by electric shock!**

Never carry out work when voltage is present.

### 7.1 Mains connection and line protection

- When connecting the 3-phase network, it is essential to observe the terminal identification.
- The following specifications apply for the fuses used.

25 A (Diazed)	Line protection for maximum cable cross section of 2.5 mm <sup>2</sup>
16 A FF (10 x 38 mm)	Device protection (500 V/10 kA network)
16 A (automatic device B, circuit breaker)	Short circuit (400 V/1.5 kA network)
20 A TRS20R20A (fuse)	Short circuit (500 V/5 kA network)
25 A gl-gG (fuse)	Short circuit (500 V/10 kA network)

- The control supply voltage and control voltage inputs must be operated with power supply modules according to DIN 19240 (max. 5 % residual ripple).
- In order to avoid inductive or capacitive coupling of noise emissions where long control wires are used, we recommend the use of shielded conductors.



**NOTE: Electrical safety**

Only connect conductors with the same conductor cross section to a terminal point.

## 7.2 Connecting cables

Insert solid or stranded conductors with ferrules directly in the clamping space (A). Reliable contact can be made with stranded conductors without ferrules by opening the spring beforehand using the pushbutton (B). Press the pushbutton (B) also to release the conductor.

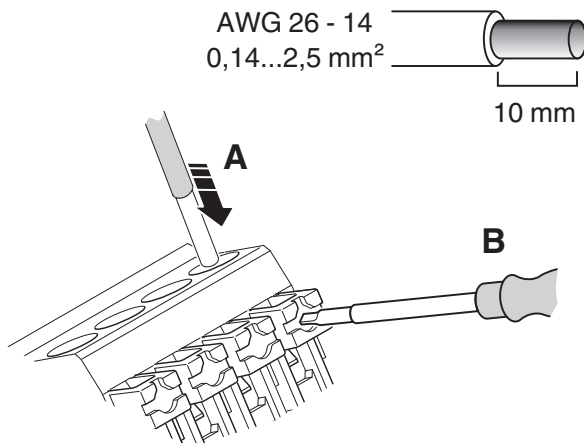

Figure 2 Connecting cables

## 7.3 Block diagram

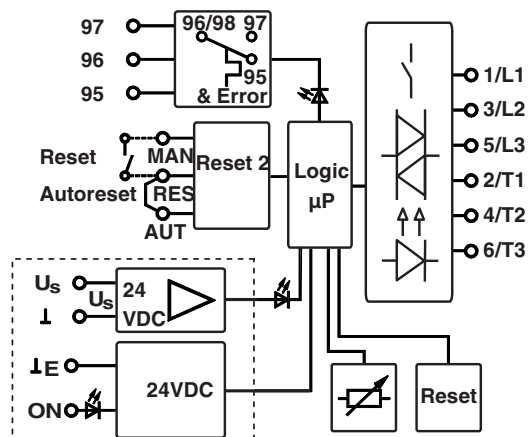

Figure 3 Block diagram



## 8 Function

### 8.1 Status and diagnostics indicators

The device visualizes the operating statuses with a total of four LEDs.

The functions of the LEDs follow the NE 44 NAMUR recommendation.

LED PWR	Green	Device status
LED I <sub>adj.</sub>	Yellow	Current adjustment
LED ON	Yellow	Forward running
LED ERR	Red	Internal or external error
		Process errors: overcurrent, asymmetry, phase failure

After applying the control supply voltage, all LEDs light up once as an LED test.

### 8.2 Diagnostic function

Various diagnostic functions enable the hybrid motor starter to detect many internal errors and also external errors (I/O errors).

If an error is detected, the device is switched to the safe shutdown state.

All internal errors cannot be acknowledged and are stored in the device. Afterwards the device cannot be started up.

In case of external errors, an error acknowledgment is required to exit the safe shutdown state.

The flashing PWR LED indicates a message.

In case of a message, the power path remains switched on; an acknowledgement is not required.

Explanation: A = LED switched off / E = LED lights continuously / B = LED flashes ca. 2 Hz (50:50) / Aut = Automatic / Man = Manual / Nm = Not possible / Ne = Not required

Status	Description	PWR	ERR	I <sub>adj.</sub>	ON	Error acknowledgment
		Green	Red	Yellow		
OFF	Supply voltage not present	A	A	A	A	-
Ready to operate	Supply voltage present	E	A	A	A	-
Drive switched on		E	A	A	E	
Internal error	Internal device error - <b>device replacement required</b>	E	E	A	A	Nm
External error in the controller or the I/O devices (maintenance requirement, NE44)	<b>Motor protection function:</b> The motor current is higher than the motor nominal current specification: Cooling time elapsing (20 minutes)	E	B	A	E	Aut
	After 2 min, "ON" flashes: a manual reset is possible	E	B	A	B	Man
	<b>Error restoring the system state:</b> Checksum error. The thermal memory of the motor protection function is set to the maximum value. The error must be manually acknowledged.	E	B	B	B	Man
	<b>Symmetry:</b> The two motor currents deviate from each other by more than 33 %.	E	B	A	A	Man
	<b>Blocking:</b> The max. measurable motor current is exceeded for more than 2 s.	E	B	A	B	Man
Message (power path remains switched on)	<b>Message with pending control signal:</b> - 2 or more phases are missing - No motor connected - Motor current in at least two phases > 2 s below the minimum current value that can be set	B	B	A	E	Ne

### Error acknowledgment

Three different options are available for error acknowledgment.

#### Manual (reset button)

Press the reset button on the front of the device.

When pressing the reset button for more than 2 s (approximately), the device returns to the error state.

Pressing the reset button for more than 6 s changes the device to the "Parameterization" mode.

#### Manual (remote acknowledgment point)

Connect a button (N/O contact) between the MAN and RES terminals.

An acknowledgement is triggered as soon as a positive edge is detected at the MAN input. If no negative edge is detected after approx. 2 s, the device adopts an error state since manipulation or an error in the acknowledgment circuit may have occurred.

#### Automatic

Establish an electrical connection between the RES and AUT terminals.

Following triggering of motor protection monitoring and subsequent cooling, the device performs an automatic acknowledgment.



The RES terminal provides the voltage for the reset.  
In variants with a rated control supply voltage of 24 V DC, this is 24 V DC.

### Feedback

As soon as the device detects an error or indicates a message, the reply relay is switched, i.e. the N/O contact is closed or the N/C contact is opened. This behavior matches that of a motor protection switch or motor protection relay.



The feedback is for signaling purposes only and is not part of the safety chain. It is therefore not included in the safety considerations.

### 8.3 Parameterization - Nominal current setting

- Press the reset button for more than 6 s to change to the "Parameterization" mode. The green PWR flashes once.

In the Parameterization mode, the LEDs are switched off every 2 s for 0.3 s to distinguish this mode from other operating modes.

- Set the nominal drive current with the 240° potentiometer. The nominal current is specified in 16 stages. The four LEDs show the set current.

Code				Nominal current [mA]		
PWR	ERR	I <sub>adj.</sub>	ON	0.6 A	2 A	9 A
0	0	0	0	75	180	1500
0	0	0	1	110	250	2000
0	0	1	0	145	410	2500
0	0	1	1	180	560	3000
0	1	0	0	215	710	3500
0	1	0	1	250	870	4000
0	1	1	0	285	1020	4500
0	1	1	1	320	1170	5000
1	0	0	0	355	1330	5500
1	0	0	1	390	1480	6000
1	0	1	0	425	1630	6500
1	0	1	1	460	1790	7000
1	1	0	0	495	1940	7500
1	1	0	1	530	2090	8000
1	1	1	0	565	2250	8500
1	1	1	1	600	2400	9000

- Store this value by pressing the reset button again (non-volatile area of the mass storage).
- Press the reset button for more than 2 s (and less than 6 s) to display the set current for 3 s. This function is only possible if 1) the device is not activated, and 2) there is no error at the device.



#### NOTE

Lock monitoring is activated from a motor current of 45 A.

## 9 Application examples



### NOTE

Switching off the control voltage supply with a controlled motor always results in wear in the hybrid motor starter.

This type of switching off should only be used if no more than 10,000 shutdowns can be expected over the entire lifetime of the system.

### 9.1 Emergency stop

The hybrid motor starter can be integrated into an emergency stop chain.

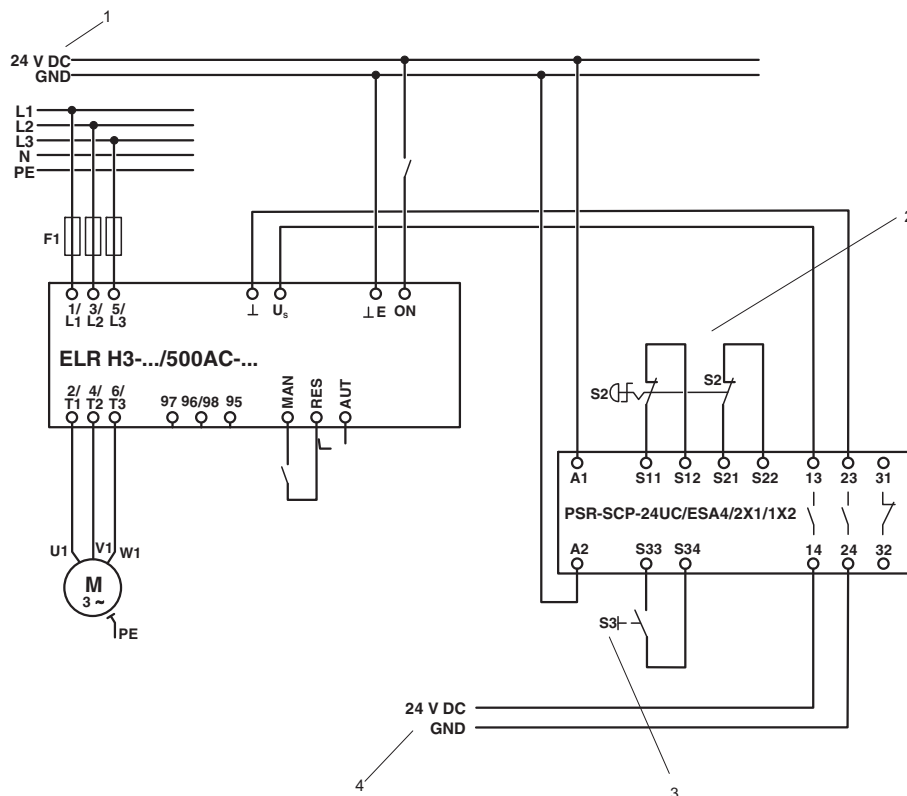

Figure 4 Emergency stop

- 1 Supply 1
- 2 Emergency stop
- 3 Reset button
- 4 Supply 2

The control supply voltage is switched off via a safety relay as soon as the emergency stop button is actuated.

If shutdown is performed, e.g., from a “safe controller” with semiconductor outputs, the residual voltage must be < 5 V DC.

Interruptions  $\leq 1$  ms are filtered.

## 9.2 Safety door (emergency stop)

In applications where safety shutdown is a normal operating state, e.g., for safety door or two-hand applications, it is the control circuit that is switched and not the control supply voltage.

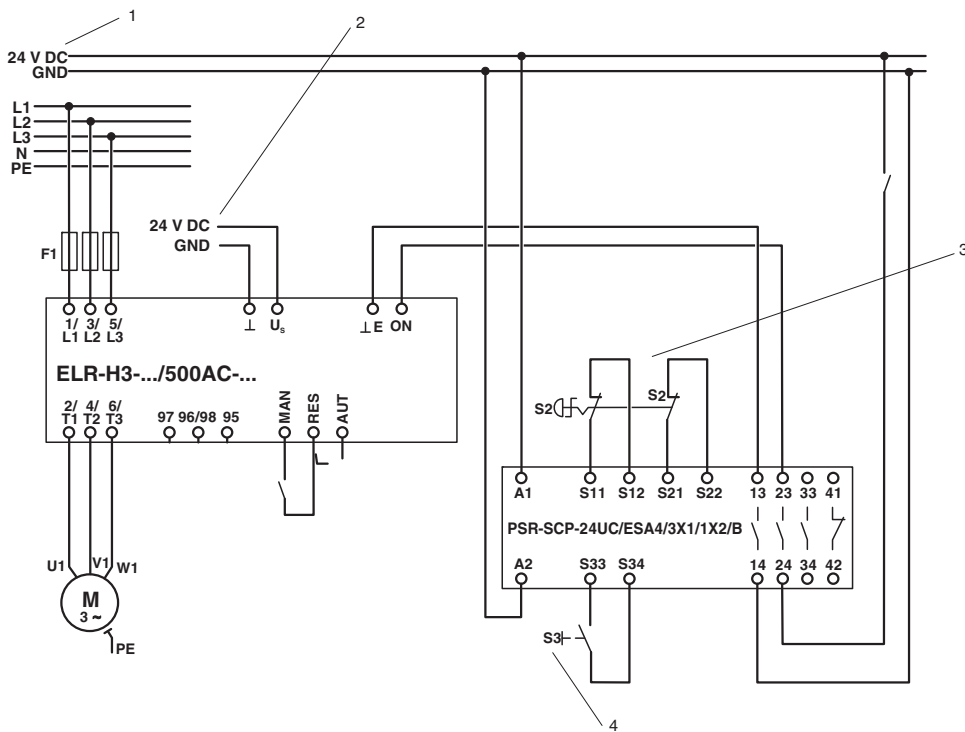

Figure 5 Safety door (emergency stop)

- 1 Supply 1
- 2 Supply 2
- 3 Emergency stop
- 4 Reset button

If shutdown is performed, e.g., from a “safe controller” with semiconductor outputs, the residual voltage must be < 5 V DC.

Interruptions  $\leq 3$  ms are filtered.

### 9.3 Motor protection

All safety-related functions are implemented by the hybrid motor starter without external influences. Special circuit technology is not required.

The wiring of the load circuit should be implemented as described in the examples.

However, the module power supply can be connected directly to the voltage source, without the PSR safety relay. The same applies for the control.

The motor currents are measured at phases L1 and L3 and monitored for symmetry.

In the event of a deviation of  $\geq 33\%$ , the motor shuts down after 2 minutes.

In the event of a deviation of  $\geq 67\%$  (e.g., phase failure), the motor shuts down after 1.8 seconds.

The deviation can be calculated using the following formulas.

$$\text{Value } I_{\max} > I_{\text{nom}} \Rightarrow (I_{\max} - I_{\min})/I_{\max}$$

$$\text{Value } I_{\max} < I_{\text{nom}} \Rightarrow (I_{\max} - I_{\min})/I_{\text{nom}}$$

### 9.4 Motor with brake

If a motor with brake (connection in the motor terminal board) is connected, the 400 V AC brake must be linked to the 2/T1 and 6/T3 terminals. A 230 V AC brake must be connected to the 4/T2 terminals and the star point of the motor.



#### NOTE

Increase motor current monitoring to the nominal brake current. This should be set accordingly on the hybrid motor starter.

### 9.5 Auxiliary relay connection

Auxiliary relay (e. g. PLC RSC 230UC/21, order no.: 2966207) for activating external brakes or acknowledgements, e. g. to the PLC, must be connected to the 4T2 and N connections of the system.

## 10 Safety functions

System conditions	
Database for failure rates	SN 29500
System type (consisting of subsystems)	Type B
Standard used	IEC 61508
Beta factor	1 %
MTTF [years] (mean time to failure at ambient temperature of 40°C)	43.0

### 10.1 Safe shutdown

Ambient temperature	40 °C
MTTFd [years] - mean time to dangerous failure	518
Shutdown time [ms]	80
$\lambda_{sd}$ [FIT] - safe, detectable	543
$\lambda_{su}$ [FIT] - safe, undetectable	852
$\lambda_{dd}$ [FIT] - dangerous, detectable	218
$\lambda_{du}$ [FIT] - dangerous, undetectable	2.4
SFF [%] - safe failure fraction	99.9
DCS [%] - diagnostic coverage safe	38.9
DC [%] - diagnostic coverage	99
PFH - probability of failure per hour	$2.4 \times 10^{-9}$
Safety level according to	IEC/CEI 61508-1: SIL 3
	ISO 13849-1: category 3 PL e
	EN 954-1: category 3

### 10.2 Motor protection

Ambient temperature	40 °C
MTTFd [years] - mean time to dangerous failure	447
Shutdown time [ms]	According to Class 10A, IEC/CEI 60947
$\lambda_{sd}$ [FIT] - safe, detectable	517
$\lambda_{su}$ [FIT] - safe, undetectable	809
$\lambda_{dd}$ [FIT] - dangerous, detectable	239
$\lambda_{du}$ [FIT] - dangerous, undetectable	17
SFF [%] - safe failure fraction	99
DCS [%] - diagnostic coverage safe	39.0
DC [%] - diagnostic coverage	93.3
Safety level according to	IEC/CEI 61508-1: SIL 2



Additional safety data is available on request.

## 11 Trigger characteristic for 20°C

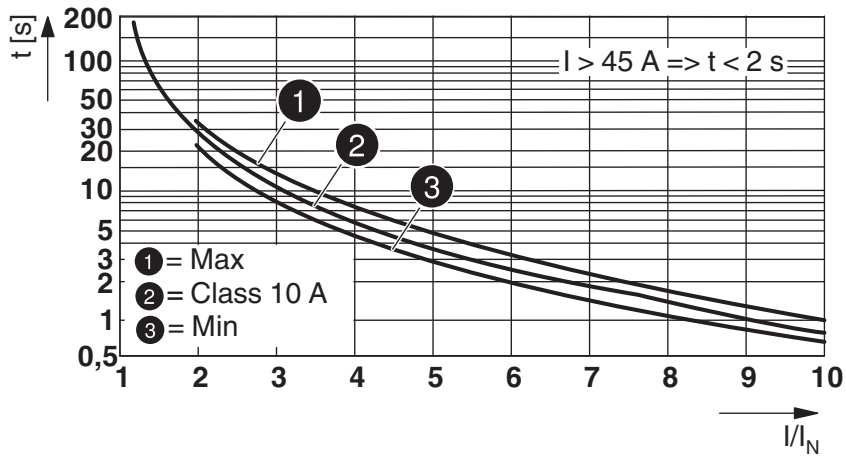

Figure 6 Trigger characteristic

$t$  [s] Release time in seconds

$I/I_N$  Overcurrent factor: the ratio between the actual current and the parameterized nominal current



## 12 Derating curves for 100% operating time

Additional data is available on request.

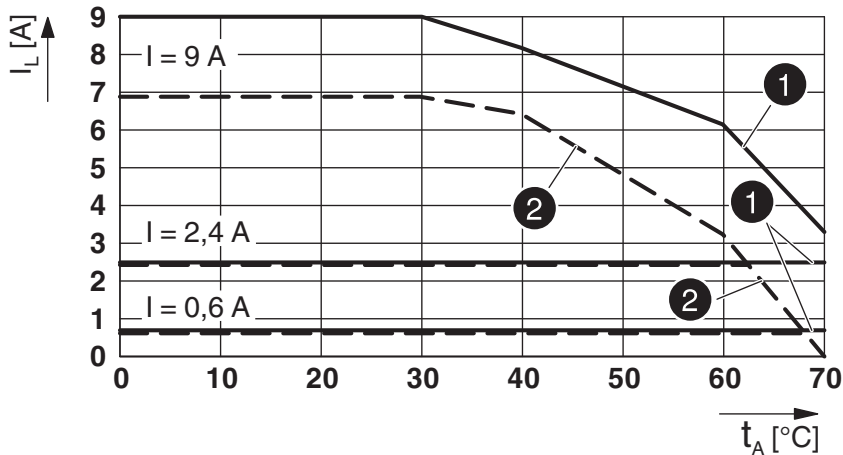

Figure 7 Derating curve

- $I_L$  = Load current [A]
- $t_A$  = Ambient temperature [°C]
- $I_A$  = Starting current [A]
- ① = Aligned with 20 mm spacing
- ② = Aligned without spacing

The adjustment factors described here refer to hybrid motor starters with a maximum load current of 9 A. You can determine the maximum permissible rated current of the motor using the load current, the overcurrent factor (see data sheet of the relevant motor), and the 9 A derating curve.

9 A derating curve										
Overcurrent factor $I_A/I_N$	1	2	3	4	5	6	7	8	9	10
Adjustment factor K	1	1	1	1	1	0.96	0.83	0.72	0.64	0.58

Overcurrent factor 1                      Utilization category AC-51  
 Overcurrent factor 8                      Utilization category AC-53a

Example 1	
Motor with overcurrent factor $I_A/I_N$ (from motor data sheet)	8
Adjustment factor K	0.72
Max. permissible load current $I_L$ at 30°C, not aligned (from derating curve)	9 A
Max. permissible rated current $I_N$ of the motor	6.5 A

Example 2	
Motor with overcurrent factor $I_A/I_N$ (from motor data sheet)	5
Adjustment factor K	1
Max. permissible load current $I_L$ at 60°C, aligned (from derating curve)	3.2 A
Max. permissible rated current $I_N$ of the motor	3.2 A

## Данный компонент на территории Российской Федерации

### Вы можете приобрести в компании MosChip.

Для оперативного оформления запроса Вам необходимо перейти по данной ссылке:

<http://moschip.ru/get-element>

Вы можете разместить у нас заказ для любого Вашего проекта, будь то серийное производство или разработка единичного прибора.

В нашем ассортименте представлены ведущие мировые производители активных и пассивных электронных компонентов.

Нашей специализацией является поставка электронной компонентной базы двойного назначения, продукции таких производителей как XILINX, Intel (ex.ALTERA), Vicor, Microchip, Texas Instruments, Analog Devices, Mini-Circuits, Amphenol, Glenair.

Сотрудничество с глобальными дистрибьюторами электронных компонентов, предоставляет возможность заказывать и получать с международных складов практически любой перечень компонентов в оптимальные для Вас сроки.

На всех этапах разработки и производства наши партнеры могут получить квалифицированную поддержку опытных инженеров.

Система менеджмента качества компании отвечает требованиям в соответствии с ГОСТ Р ИСО 9001, ГОСТ РВ 0015-002 и ЭС РД 009

### Офис по работе с юридическими лицами:

105318, г.Москва, ул.Щербаковская д.3, офис 1107, 1118, ДЦ «Щербаковский»

Телефон: +7 495 668-12-70 (многоканальный)

Факс: +7 495 668-12-70 (доб.304)

E-mail: [info@moschip.ru](mailto:info@moschip.ru)

Skype отдела продаж:

moschip.ru

moschip.ru\_4

moschip.ru\_6

moschip.ru\_9