

### Features

- UNII, Hiperlan, and 802.11a+b/g Applications
- Broadband Performance: DC-6 GHz
- Low Insertion Loss: 0.9 dB at 6 GHz
- High Isolation: 28 dB Typical
- Fast Switching Speed: 0.5  $\mu$ m GaAs PHEMT
- High Power: 36 dBm P1dB
- Fast Settling for Low Gate Lag Requirements
- Lead-Free 3 mm 12-lead PQFN Package
- 100% Matte Tin Plating over Copper
- Halogen-Free "Green" Mold Compound
- RoHS\* Compliant and 260°C Reflow Compatible

### Description

M/A-COM's MASW-007588 is a broadband GaAs PHEMT MMIC SPDT switch in a low cost, lead-free 3 mm 12-lead PQFN package. The MASW-007588 is ideally suited for applications where very small size and low cost are required.

The MASW-007588, with its small size and low height, is ideal for 802.11a and 802.11b/g PC card and access point applications.

The MASW-007588 delivers high isolation, low insertion loss and high linearity up to 6 GHz.

The MASW-007588 is fabricated using a 0.5 micron gate length GaAs PHEMT process. The process features full passivation for performance and reliability.

### Ordering Information<sup>1</sup>

Part Number	Package
MASW-007588-TR3000	3000 piece reel
MASW-007588-000SMB	Sample Test Board (Includes 5 Samples)

1. Reference Application Note M513 for reel size information.

### Functional Schematic

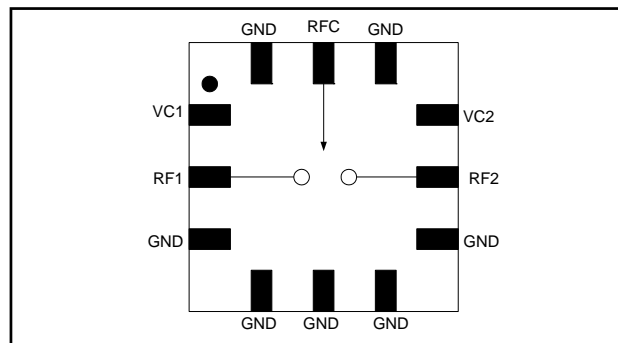

### Pin Configuration

PIN No.	PIN Name	Description
1	VC1	Control 1
2	RF1	RF Port 1
3	GND	Ground
4	GND	Ground
5	GND	Ground
6	GND	Ground
7	GND	Ground
8	RF2	RF Port 2
9	VC2	Control 2
10	GND	Ground
11	RFC	RF Input
12	GND	Ground
13	Paddle <sup>2</sup>	RF and DC Ground

2. The exposed pad centered on the package bottom must be connected to RF and DC ground.

### Absolute Maximum Ratings<sup>3,4</sup>

Parameter	Absolute Maximum
Input Power @ 3 V Control	+37 dBm
Input Power @ 5 V Control	+39 dBm
Operating Voltage	+8.5 volts
Operating Temperature	-40°C to +85°C
Storage Temperature	-65°C to +150°C

3. Exceeding any one or combination of these limits may cause permanent damage to this device.
4. M/A-COM does not recommend sustained operation near these survivability limits.

\* Restrictions on Hazardous Substances, European Union Directive 002/95/EC.

**ADVANCED:** Data Sheets contain information regarding a product M/A-COM Technology Solutions is considering for development. Performance is based on target specifications, simulated results, and/or prototype measurements. Commitment to develop is not guaranteed.

**PRELIMINARY:** Data Sheets contain information regarding a product M/A-COM Technology Solutions has under development. Performance is based on engineering tests. Specifications are typical. Mechanical outline has been fixed. Engineering samples and/or test data may be available. Commitment to produce in volume is not guaranteed.

• **North America** Tel: 800.366.2266 / Fax: 978.366.2266  
 • **Europe** Tel: 44.1908.574.200 / Fax: 44.1908.574.300  
 • **Asia/Pacific** Tel: 81.44.844.8296 / Fax: 81.44.844.8298  
 Visit [www.macomtech.com](http://www.macomtech.com) for additional data sheets and product information.

M/A-COM Technology Solutions Inc. and its affiliates reserve the right to make changes to the product(s) or information contained herein without notice.

**Electrical Specifications<sup>5</sup>:  $T_A = 25^\circ\text{C}$ ,  $Z_0 = 50\Omega$ ,  $V_c = 0\text{ V}/3\text{ V}$ ,  $\text{Pin} = 0\text{ dBm}$**

Parameter	Test Conditions	Units	Min.	Typ.	Max.
Insertion Loss	2.4 GHz	dB	—	0.70	1.05
	5.3 GHz	dB	—	0.85	1.2
	5.8 GHz	dB	—	0.85	1.2
Isolation	2.4 GHz	dB	24	29	—
	5.3 GHz	dB	23	28	—
	5.8 GHz	dB	21	26	—
Return Loss	DC - 6 GHz	dB	—	20	—
IP2	Two Tone, +15 dBm/Tone, 5 MHz Spacing, >50 MHz				
	2.4 GHz, $V_c = 3.0\text{ V}$	dBm	—	98	—
	5.8 GHz, $V_c = 3.0\text{ V}$	dBm	—	81	—
	2.4 GHz, $V_c = 5.0\text{ V}$	dBm	—	107	—
IIP3	Two Tone, +15 dBm/Tone, 5 MHz Spacing, >50 MHz				
	2.4 GHz, $V_c = 3.0\text{ V}$	dBm	—	57	—
	5.8 GHz, $V_c = 3.0\text{ V}$	dBm	—	53	—
	2.4 GHz, $V_c = 5.0\text{ V}$	dBm	—	57	—
Input P-1dB	2.4 GHz	dBm	—	40	—
	5.3 GHz	dBm	—	36	—
	5.8 GHz	dBm	—	37	—
2nd Harmonic	2.4 GHz, $\text{Pin} = +20\text{ dBm}$	dBm	—	-72	—
	5.8 GHz, $\text{Pin} = +20\text{ dBm}$	dBm	—	-69	—
3rd Harmonic	2.4 GHz, $\text{Pin} = +20\text{ dBm}$	dBm	—	-85	—
	5.8 GHz, $\text{Pin} = +20\text{ dBm}$	dBm	—	-75	—
T-rise, T-fall	10% to 90% RF and 90% to 10% RF	nS	—	55	—
Ton, Toff	50% control to 90% RF, and 50% control to 10% RF	nS	—	80	—
Transients	—	mV	—	14	—
Control Current	$ V_c  = 3\text{ V}$	$\mu\text{A}$	—	15	25

**Truth Table<sup>5,6,7</sup>**

Control V1	Control V2	RFC—RF1	RFC—RF2
1	0	On	Off
0	1	Off	On

- For positive voltage control, external DC blocking capacitors are required on all RF ports.
- Differential voltage,  $V(\text{state } 1) - V(\text{state } 0)$ , must be +2.7 V minimum and must not exceed +5 V.
- $0 = 0 \pm 0.2\text{ V}$ ,  $1 = +2.9\text{ V}$  to +5 V.

**Handling Procedures**

Please observe the following precautions to avoid damage:

**Static Sensitivity**

Gallium Arsenide Integrated Circuits are sensitive to electrostatic discharge (ESD) and can be damaged by static electricity. Proper ESD control techniques should be used when handling these devices.

### Typical Performance Curves

**Insertion Loss**

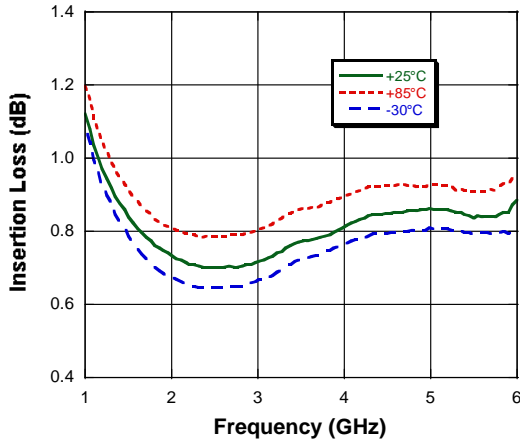

**Isolation**

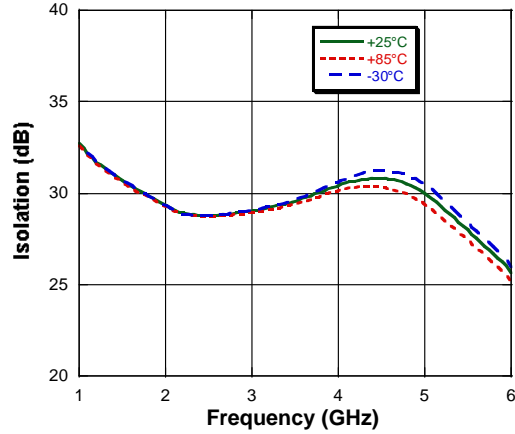

**Return Loss**

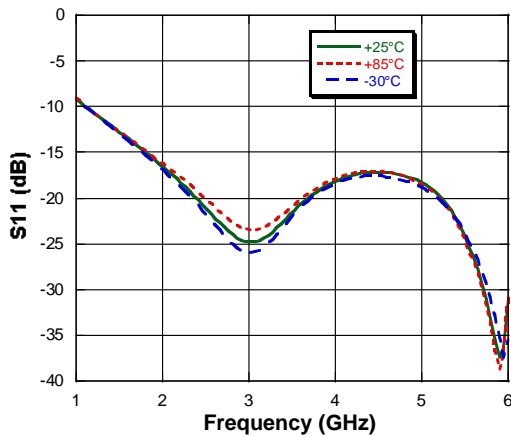

**Application Schematic**

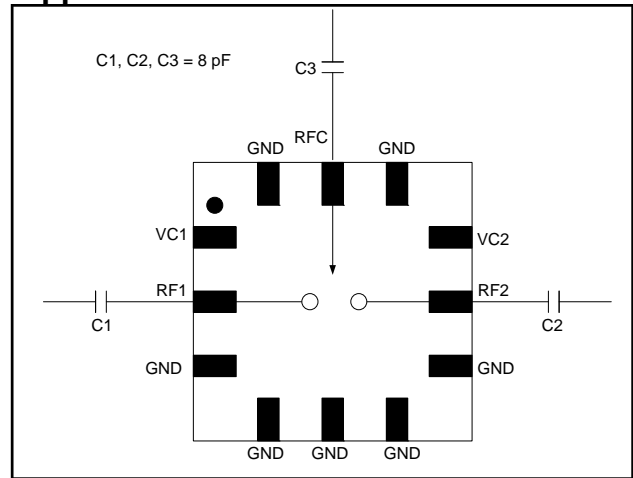

### Lead-Free 3 mm 12-lead PQFN†

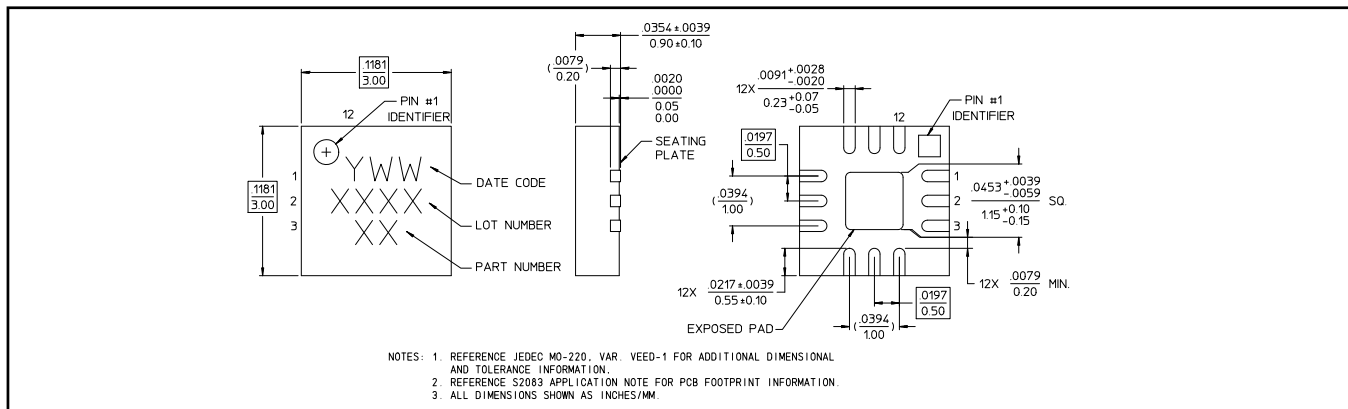

† Reference Application Note M538 for lead-free solder reflow recommendations.

**ADVANCED:** Data Sheets contain information regarding a product M/A-COM Technology Solutions is considering for development. Performance is based on target specifications, simulated results, and/or prototype measurements. Commitment to develop is not guaranteed.  
**PRELIMINARY:** Data Sheets contain information regarding a product M/A-COM Technology Solutions has under development. Performance is based on engineering tests. Specifications are typical. Mechanical outline has been fixed. Engineering samples and/or test data may be available. Commitment to produce in volume is not guaranteed.

• **North America** Tel: 800.366.2266 / Fax: 978.366.2266  
• **Europe** Tel: 44.1908.574.200 / Fax: 44.1908.574.300  
• **Asia/Pacific** Tel: 81.44.844.8296 / Fax: 81.44.844.8298  
Visit [www.macomtech.com](http://www.macomtech.com) for additional data sheets and product information.

M/A-COM Technology Solutions Inc. and its affiliates reserve the right to make changes to the product(s) or information contained herein without notice.

## Данный компонент на территории Российской Федерации

### Вы можете приобрести в компании MosChip.

Для оперативного оформления запроса Вам необходимо перейти по данной ссылке:

<http://moschip.ru/get-element>

Вы можете разместить у нас заказ для любого Вашего проекта, будь то серийное производство или разработка единичного прибора.

В нашем ассортименте представлены ведущие мировые производители активных и пассивных электронных компонентов.

Нашей специализацией является поставка электронной компонентной базы двойного назначения, продукции таких производителей как XILINX, Intel (ex.ALTERA), Vicor, Microchip, Texas Instruments, Analog Devices, Mini-Circuits, Amphenol, Glenair.

Сотрудничество с глобальными дистрибьюторами электронных компонентов, предоставляет возможность заказывать и получать с международных складов практически любой перечень компонентов в оптимальные для Вас сроки.

На всех этапах разработки и производства наши партнеры могут получить квалифицированную поддержку опытных инженеров.

Система менеджмента качества компании отвечает требованиям в соответствии с ГОСТ Р ИСО 9001, ГОСТ РВ 0015-002 и ЭС РД 009

### Офис по работе с юридическими лицами:

105318, г.Москва, ул.Щербаковская д.3, офис 1107, 1118, ДЦ «Щербаковский»

Телефон: +7 495 668-12-70 (многоканальный)

Факс: +7 495 668-12-70 (доб.304)

E-mail: [info@moschip.ru](mailto:info@moschip.ru)

Skype отдела продаж:

moschip.ru

moschip.ru\_4

moschip.ru\_6

moschip.ru\_9