

Features

- 90° Quadrature Phase
- Frequency Range: 0.05 - 18 GHz
- Temperature Range: -65° to 125°C
- Meets MIL-E-5400 Environments
- Non-crossover Versions Available

Description

3 dB quadrature mini-hybrids are the ultimate in compact, rugged high stress environment components. The crossover feature of the location of both outputs on one side allows simplicity in system or subsystem design. Multi-octave coverage of the complete frequency spectrum, along with high isolation performance, qualifies them as an asset to any system.

Outline Drawing

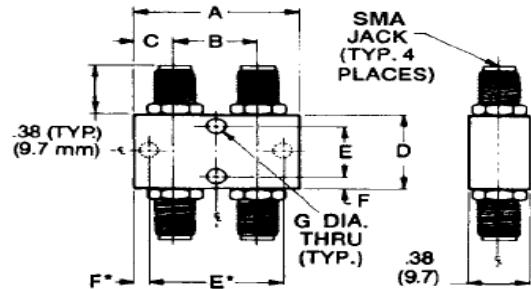

All dimensions are $\pm .020$ except mounting diameters ($\pm .005$) and mounting hole location ($\pm .010$).

90° Crossover Electrical Specifications

Part Number	Case Style	Freq. Range (GHz)	Amplitude Balance (dB)	Insertion Loss Max (dB)	Isolation Min. (dB)	VSWR Max	Power Avg. (W)	Power Pk. (kW)
2032-6344-00	3	1.0 - 2.0	± 0.5	0.20	22	1.20	30	3
2032-6345-00	4	2.0 - 4.0	± 0.5	0.25	22	1.25	30	3
2032-6347-00	5	4.0 - 8.0	± 0.5	0.30	20	1.25	30	3
2032-6348-00	5	8.0 - 12.4	± 0.5	0.50	18	1.35	30	3
2032-6349-00	5	12.4 - 18.0	± 0.5	0.50	18	1.45	30	3
2032-6350-00	6	0.5 - 2.0	± 0.5	0.60	24	1.20	30	3
2032-6352-00	7	2.0 - 8.0	± 0.5	0.50	20	1.30	30	3
2032-6354-00	8	4.0 - 12.4	± 0.5	0.60	20	1.25	50	3
2032-6371-00	10	2.0 - 18.0	± 1.0	0.60***	20****	1.45	50	3
2032-6374-00	5	6.5 - 18.0	± 0.5	0.60	18	1.35	30	3
2032-6375-00	11	4.0 - 18.0	± 0.5	1.0	18	1.45	100	5

*** Insertion loss is 1.2 dB from 6.0 to 12.4 GHz and 1.5 dB from 12.4 to 18.0 GHz.
 **** Isolation is 15 dB from 12.4 to 18.0 GHz.

2032-6350-00 to 2032-6375-00 are multi-octave.
 2032-6375-00 is high power.

90° Crossover Mechanical Specifications

Case Style	A Inch (mm)	B Inch (mm)	C Inch (mm)	D Inch (mm)	E Inch (mm)	F Inch (mm)	G Inch (mm)	Weight oz	Weight g
3	1.78 (45.2)	1.28 (32.5)	0.25 (6.35)	0.50 (12.7)	0.31 (7.9)	0.09 (2.4)	0.104 (2.6)	0.84	24
4	1.16 (29.4)	0.66 (16.7)	0.25 (6.35)	0.50 (12.7)	0.31 (7.9)	0.09 (2.4)	0.104 (2.6)	0.65	19
5	1.0 (25.4)	0.50 (12.7)	0.25 (6.35)	0.50 (12.7)	0.31 (7.9)	0.09 (2.4)	0.104 (2.6)	0.60	17
6	5.58 (141.7)	5.0 (127)	0.29 (7.3)	0.70 (17.9)	5.42 (137.7)	0.08 (2.0)	0.093 (2.4)	2.35	67
7	1.71 (43.4)	1.21 (30.7)	0.25 (6.33)	0.50 (12.7)	0.31 (7.9)	0.09 (2.4)	0.104 (2.6)	0.82	23
8	1.72 (43.7)	1.22 (31)	0.25 (6.33)	1.07 (27.2)	0.58 (14.7)	0.57 (14.5)	0.104 (2.6)	1.40	40
10	1.88 (47.6)	1.41 (35.9)	0.23 (5.7)	1.3 (33)	1.06 (26.9)	0.12 (3.1)	0.14 (3.6)	1.76	50
11	1.50 (38.1)	1.00 (25.4)	0.25 (6.4)	1.10 (28.0)	0.90 (23.0)	0.10 (2.5)	0.104 (2.6)	1.41	40

Features

- Air Dielectric
- Non-crossover Design
- 90° Quadrature Phase
- Frequency Range: 1.0 - 18 GHz
- Temperature Range: -50° to +110°C
- Meets MIL-E-5400 Environments and MIL-E-16400 Environments
- MIL-C-15370/8 Equivalent

Description

These 3dB coaxial hybrids are ultra-compact. A signal applied into any terminal appears at both outputs with one-half the amplitude and shifted 90 degrees out of phase. The units mount four SMA jack, low VSWR connectors. These couplers may be used in mixers, duplexers and other applications requiring equal power division.

Outline Drawing

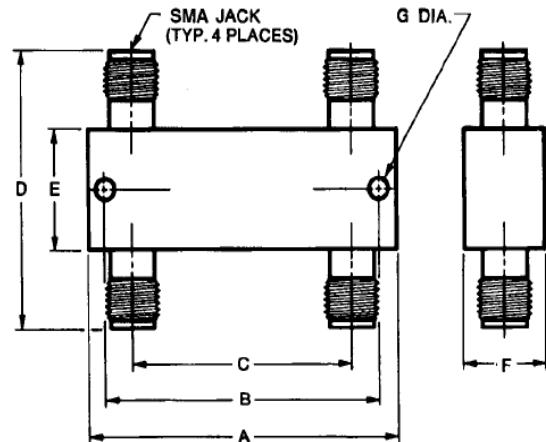

All dimensions are $\pm .020$ except mounting diameters ($\pm .005$) and mounting hole location ($\pm .010$).

90° Non-Crossover Electrical Specifications

Part Number	Model No.	Case Style	Freq. Range (GHz)	Amplitude Balance (dB)	Insertion Loss Max (dB)	Isolation Min. (dB)	VSWR Max	Power Avg. (W)	Power Pk. (kW)
2035-6364-00	20153-3	1	1.0 - 2.0	± 0.4	0.20	20	1.25	50	3
2035-6365-00	20154-3	2	2.0 - 4.0	± 0.5	0.20	18	1.25	50	3
2035-6366-00	201545-3	3	2.6 - 5.2	± 0.5	0.20	18	1.25	50	3
2035-6367-00	20155-3	4	4.0 - 8.0	± 0.5	0.30	18	1.25	50	3
2035-6368-00	20156-3	5	8.0 - 12.4	± 0.5	0.35	15	1.30	50	3
2035-6369-00	20157-3	5	12.4 - 18.0	± 0.5	0.35	15	1.35	50	5

90° Non-Crossover Mechanical Specifications

Case Style	A Inch (mm)	B Inch (mm)	C Inch (mm)	D Inch (mm)	E Inch (mm)	F Inch (mm)	G Inch (mm)	Weight oz	Weight g
1	2.55 (64.8)	2.39 (60.8)	1.97 (50.1)	1.16 (29.5)	0.50 (12.7)	0.38 (9.7)	0.093 (2.4)	1.80	52
2	1.69 (42.7)	1.52 (38.7)	1.11 (28.2)	1.16 (29.5)	0.50 (12.7)	0.38 (9.7)	0.093 (2.4)	1.10	32
3	1.41 (35.6)	1.24 (31.5)	0.82 (20.8)	1.16 (29.5)	0.50 (12.7)	0.38 (9.7)	0.093 (2.4)	0.99	28
4	1.13 (28.7)	0.97 (24.7)	0.55 (14)	1.16 (29.5)	0.50 (12.7)	0.38 (9.7)	0.093 (2.4)	0.89	26
5	1.08 (27.4)	0.92 (23.4)	0.50 (12.7)	1.28 (32.5)	0.63 (15.9)	0.38 (9.7)	0.093 (2.4)	0.93	27

Features

- Crossover Design
- 0° or 180° Phase Difference
- High Isolation
- Low VSWR
- Multi-Octave Frequency Range
- Temperature Range: -65° to +125°C
- Meets MIL-E-5400 and MIL-E-16400 Environments

Description

These 3 dB 180° mini-hybrids are highly reliable rugged stripline-constructed units that can be used either to divide or combine R.F. power. A signal incident at the sum (Σ) port will yield in-phase amplitude balanced signals at the output ports. Conversely, a signal applied to the difference (Δ) port will yield amplitude balanced and 180° out of phase signals at the output ports.

Outline Drawing

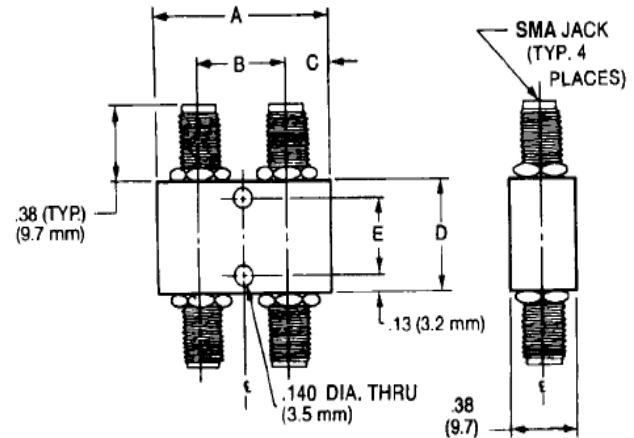

All dimensions are $\pm .020$ except mounting diameters ($\pm .005$) and mounting hole location ($\pm .010$).

180° Crossover Electrical Specifications

Part Number	Case Style	Freq. Range (GHz)	Amplitude Balance (dB)	Insertion Loss Max (dB)	Isolation Min. (dB)	VSWR Max	Phase Balance (Degrees)	Power Avg. (W)	Power Pk. (kW)
2031-6330-00	1	0.5 - 1.0	± 0.5	0.40	25	1.30	± 4	30	3
2031-6331-00	2	1.0 - 2.0	± 0.5	0.50	25	1.35	± 4	30	3
2031-6332-00	3	2.0 - 4.0	± 0.5	0.70	22	1.35	± 5	30	3
2031-6333-00	4	2.6 - 5.2	± 0.5	0.70	20	1.35	± 5	30	3
2031-6334-00	4	4.0 - 8.0	± 0.5	0.70	20	1.35	± 6	30	3
2031-6335-00	7	8.0 - 12.4	± 0.5	0.80	17	1.45	± 6	30	3
2031-6336-00	7	12.4 - 18.0	± 0.6	1.20	12	1.70	± 6	30	3
2031-6338-00	6	4.0 - 12.4	± 0.6	1.00	17	1.50	± 8	30	3
2031-6339-00	7	7.0 - 18.0	± 0.6	1.2	14	1.70	± 8	20	2

2031-6338-00 and 2031-6339-00 are multi-octave

180° Crossover Mechanical Specifications

Case Style	A Inch (mm)	B Inch (mm)	C Inch (mm)	D Inch (mm)	E Inch (mm)	Weight oz	Weight g
1	3.25 (82.6)	2.5 (63.5)	0.50 (12.7)	1.25 (31.8)	1.0 (25.4)	2.8	70
2	2.0 (50.8)	1.25 (31.8)	0.50 (12.7)	1.25 (31.8)	1.0 (25.4)	2.0	47
3	1.44 (36.5)	0.69 (17.5)	0.50 (12.7)	1.25 (31.8)	1.0 (25.4)	1.5	38
4	1.25 (31.8)	0.50 (12.7)	0.38 (9.7)	1.25 (31.8)	1.0 (25.4)	1.5	38
6	1.5 (38.1)	0.75 (19.1)	0.38 (9.7)	1.0 (25.4)	0.75 (19.1)	1.2	34
7	1.25 (31.8)	0.50 (12.7)	0.38 (9.7)	1.0 (25.4)	0.75 (19.1)	1.1	31

Данный компонент на территории Российской Федерации

Вы можете приобрести в компании MosChip.

Для оперативного оформления запроса Вам необходимо перейти по данной ссылке:

<http://moschip.ru/get-element>

Вы можете разместить у нас заказ для любого Вашего проекта, будь то серийное производство или разработка единичного прибора.

В нашем ассортименте представлены ведущие мировые производители активных и пассивных электронных компонентов.

Нашей специализацией является поставка электронной компонентной базы двойного назначения, продукции таких производителей как XILINX, Intel (ex.ALTERA), Vicor, Microchip, Texas Instruments, Analog Devices, Mini-Circuits, Amphenol, Glenair.

Сотрудничество с глобальными дистрибьюторами электронных компонентов, предоставляет возможность заказывать и получать с международных складов практически любой перечень компонентов в оптимальные для Вас сроки.

На всех этапах разработки и производства наши партнеры могут получить квалифицированную поддержку опытных инженеров.

Система менеджмента качества компании отвечает требованиям в соответствии с ГОСТ Р ИСО 9001, ГОСТ РВ 0015-002 и ЭС РД 009

Офис по работе с юридическими лицами:

105318, г.Москва, ул.Щербаковская д.3, офис 1107, 1118, ДЦ «Щербаковский»

Телефон: +7 495 668-12-70 (многоканальный)

Факс: +7 495 668-12-70 (доб.304)

E-mail: info@moschip.ru

Skype отдела продаж:

moschip.ru

moschip.ru_4

moschip.ru_6

moschip.ru_9