

DESCRIPTION

The **QP50-6SD2** is a quad photodiode array with current-to-voltage amplifiers that provide bottom minus top and left minus right difference signals. Additionally the **QP50-6SD2** provides a signal that is the sum of all four quadrant diode signals. The difference signals are voltage analogs of the light intensity difference sensed by the pairs of photodiode elements in the array. The board has a 7 pin connector attached for easy hook up.

APPLICATIONS

- NIR & visible pulsed light positioning and tracking
- Laser beam centering



OPTIONS

- Can be purchased without connector, use order # 10-031.
- For alternate gap size, see data sheet QP50-6-18u-SD2 for 18 μm gap version.
- Also available with quad detector active area sizes ranging from 1 mm² to 20 mm².

ABSOLUTE MAXIMUM RATING

SYMBOL	PARAMETER	MIN	MAX	UNITS
T _{STG}	Storage Temp	-15	+100	°C
T _{OP}	Operating Temp	0	+70	°C
V _S	Power Supply Voltage Recommended ±15V	±4.5	±18	V
V _R	Applied Bias Voltage*	0	15	V

SPECTRAL RESPONSE @ 22°C

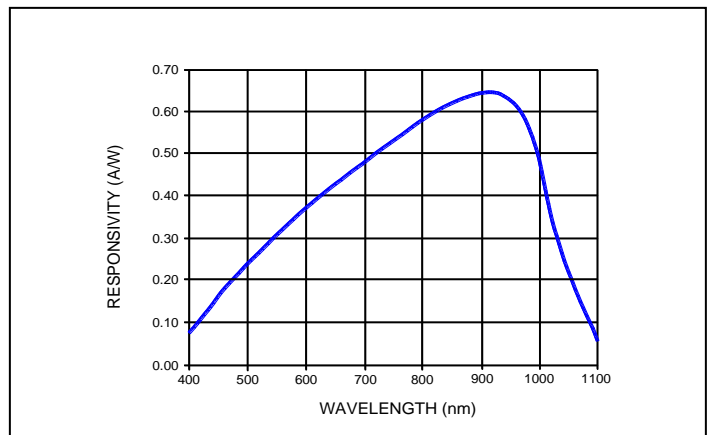

CONNECTION

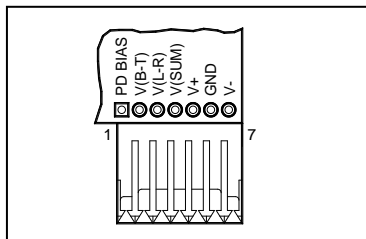

ELECTRO-OPTICAL CHARACTERISTICS @ 22° C

SYMBOL	CHARACTERISTIC	TEST CONDITIONS	MIN	TYP	MAX	UNITS
V _O	Output Voltage (all outputs)		---	+V _S - 3	---	V
			---	-V _S + 3	---	
I _O	Output Current Limit	V _S = ± 15 V; V _R = 0 V	---	---	25	mA
	Slew Rate	V _S = ± 15 V; V _R = 0 V	---	---	10	V/μs
	Theoretical noise	V _S = ± 15 V; V _R = 0 V	---	15	---	nV/√Hz
Δf _{-3dB}	Bandwidth**	V _S = ± 15 V; V _R = 5 V; λ = 880 nm	---	250	---	kHz

* actual bias voltage to photodiode: pad 1 voltage times 0.91. Do not apply negative voltages to pad 1.

** dependant on bias voltage

Disclaimer: Due to our policy of continued development, specifications are subject to change without notice.

The QP50-6SD2 outputs are labeled as B-T for bottom minus top, L-R for left minus right. The output voltages are obtained by routing the diode element currents into current-to-voltage amplifiers with a gain of 10^4 :

$$V_{B-T} = [(I_{3,4}) - (I_{1,2})] \cdot (10^4) \text{ on Pad 2.}$$

$$V_{L-R} = [(I_{2,3}) - (I_{1,4})] \cdot (10^4) \text{ on Pad 3.}$$

$$V_{SUM} = [(I_{1,2,3,4})] \cdot (10^4) \text{ on Pad 4.}$$

$I_{x,y}$ is the sum of the currents generated by photodiode elements x and y. Looking down through the window of the photodiode, the quadrants are identified in drawing on page one.

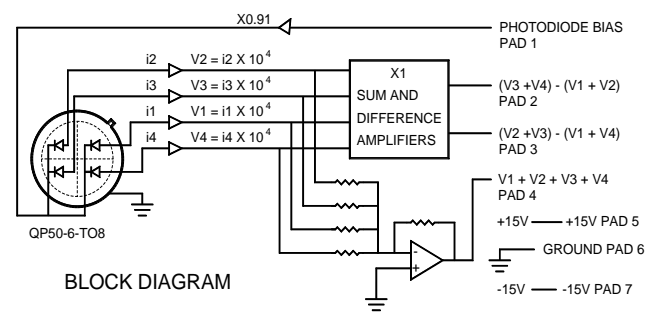

APPLICATION NOTES

Beam Size

The light spot applied to the QP50-6SD2 must be smaller than the diameter of the quadrant photodiode array. The detector active area has a diameter of 7.8 millimeters. If the light spot is too large, it may be reduced to fit the photodiode array by use of a lens. A decrease in output signal strength is observed as the light spot crosses the separation boundary of the quadrants, usually referred to as the "gap". This effect is more pronounced as the diameter of the light spot decreases, as a larger percentage of the light spot's power falls within the non-active gap. For this reason, the minimum light beam diameter should be a least one millimeter. A lens may be used to increase the beam diameter.

Photodiode Bias Operation

The QP50-6SD2 array may be operated either in the zero bias or the reverse bias mode. Pin 1 is connected, via a resistor divider, to the non-inverting input of a voltage follower operational amplifier. This line may be left unterminated, grounded or connected to a voltage source of zero volts to operate in the zero bias mode. If the photodiode bias line is connected to a positive voltage source (but less than V_{cc}), then the photodiode elements in the array will be biased at $0.91 \times V_{Bias}$. Do not connect Pin 1 to negative voltages, as this will forward bias the photodiode array, making it inoperable and possibly damaging the circuit.

Use of Sum and Difference Signals for Alignment

The sum output signal may be used to help preliminary alignment of the QP50-6SD2 to the source light beam. First, the beam or the QP50-6SD2 is adjusted for maximum sum output signal. Second, the beam or QP50-6SD2 is adjusted until the L-R and B-T signals are at minimum. This procedure results in the beam being centered on the quad photodiode array.

Signal Null Detector for Servo Applications

A common application for the QP50-6SD2 is a signal null detector as part of a servo system that maintains the position of a light beam. Errors in beam position are reported by the QP50-6SD2 and may be used to adjust a positioning device that restores the beam or the beam's source to a null position.

Speed of Response

Increasing the photodiode bias voltage will increase the speed of the QP50-6SD2. Operating with zero reverse bias is sufficient for many applications (-3dB is around 150 kHz at 880 nm). As noted above, Pin 1 is provided for applying positive bias voltage to the quad for higher frequency response. Care should be taken not to exceed the circuit common mode values and the breakdown voltage of the quad photodiode. See Absolute Maximum Ratings on page one for maximum values.

Temperature Considerations

The operation temperature must be between 0 to 70 °C. For best resolution the temperature should be kept at or below 25 °C. Thermal gradients across the detector will cause position errors and should be avoided.

Offsets

Precision components are used in the circuitry but as much as 10 millivolts of dark offset may still be present in the outputs. If this causes a problem the offsets should be removed externally.



USA

First Sensor Inc.
5700 Corsa Avenue, #105
Westlake Village, CA 91362 USA
T + 818 706-3400
F + 818 889-7053
contact.us@first-sensor.com
www.first-sensor.com

International sales

First Sensor AG
Peter-Behrens-Str. 15
12459 Berlin, Germany
T + 49 30 6399 2399
F + 49 30 639923-752
sales.opto@first-sensor.com
www.first-sensor.com

Данный компонент на территории Российской Федерации

Вы можете приобрести в компании MosChip.

Для оперативного оформления запроса Вам необходимо перейти по данной ссылке:

<http://moschip.ru/get-element>

Вы можете разместить у нас заказ для любого Вашего проекта, будь то серийное производство или разработка единичного прибора.

В нашем ассортименте представлены ведущие мировые производители активных и пассивных электронных компонентов.

Нашей специализацией является поставка электронной компонентной базы двойного назначения, продукции таких производителей как XILINX, Intel (ex.ALTERA), Vicor, Microchip, Texas Instruments, Analog Devices, Mini-Circuits, Amphenol, Glenair.

Сотрудничество с глобальными дистрибьюторами электронных компонентов, предоставляет возможность заказывать и получать с международных складов практически любой перечень компонентов в оптимальные для Вас сроки.

На всех этапах разработки и производства наши партнеры могут получить квалифицированную поддержку опытных инженеров.

Система менеджмента качества компании отвечает требованиям в соответствии с ГОСТ Р ИСО 9001, ГОСТ РВ 0015-002 и ЭС РД 009

Офис по работе с юридическими лицами:

105318, г.Москва, ул.Щербаковская д.3, офис 1107, 1118, ДЦ «Щербаковский»

Телефон: +7 495 668-12-70 (многоканальный)

Факс: +7 495 668-12-70 (доб.304)

E-mail: info@moschip.ru

Skype отдела продаж:

moschip.ru

moschip.ru_4

moschip.ru_6

moschip.ru_9