

μPG2413T6Z-EVAL-A

Evaluation Board

- Description
- Insertion Loss of Through Board
- Assembly Drawing

Description:

The uPG2413T6Z-EVAL-A evaluation board provides a quick and convenient means of evaluating the performance of the NEC uPG2413T6Z switch. In addition to the device, the board provides DC block capacitors, power supply bypass capacitors, and RF and DC connectors.

A DC block capacitor is required at all RF ports. On this board, a 56pF capacitor is used for this purpose. The chosen capacitance value minimizes the mismatch effect associated with the serial capacitor over a wide frequency range. For a narrow band application or an application where the operating frequency is outside the specific frequency range, the user may select a different capacitance value. Generally the performance of the switch circuit is not sensitive, to a certain extent, to the value of DC block capacitors.

A 1000pF capacitor is used for DC bypass on all control lines. For high speed applications the user may choose smaller capacitance.

DC and RF Connections

All ports for DC and RF connections are labeled on the board. For the complete pin-out description, refer to the data sheet. The data sheet is available from CEL's website at: www.cel.com.

Information on Board Material:

The PCB is a four layer board. The top layer is 10mil thick RO4350B. Its dielectric constant is 3.48. The middle and bottom layers are 45mil and 10mil FR4 respectively. All RF transmission lines are on top metal layer. The second metal layer is ground. The third metal layer is for DC routing and the bottom metal layer is ground.

Switch Logic Table:

The following table lists the logic table for switch states.

Vcont1	Vcont2	Vcont3	RFC-RF1	RFC-RF2	RFC-RF3
H	L	L	ON	OFF	OFF
L	H	L	OFF	ON	OFF
L	L	H	OFF	OFF	ON

Insertion Loss of Through Board:

It is necessary to take the loss through the connectors and PCB trace into account in assessing the insertion loss through the switch alone. To this end a through board was characterized to determine the board/connector loss. The table below lists the board loss at different frequencies.

INPUT FREQUENCY (GHz)	BOARD LOSS (dB)
1.0	0.08
2.0	0.16
2.5	0.23
3	0.26

REVISIONS				
ZONE	LTR	DESCRIPTION	DATE	APPROVED

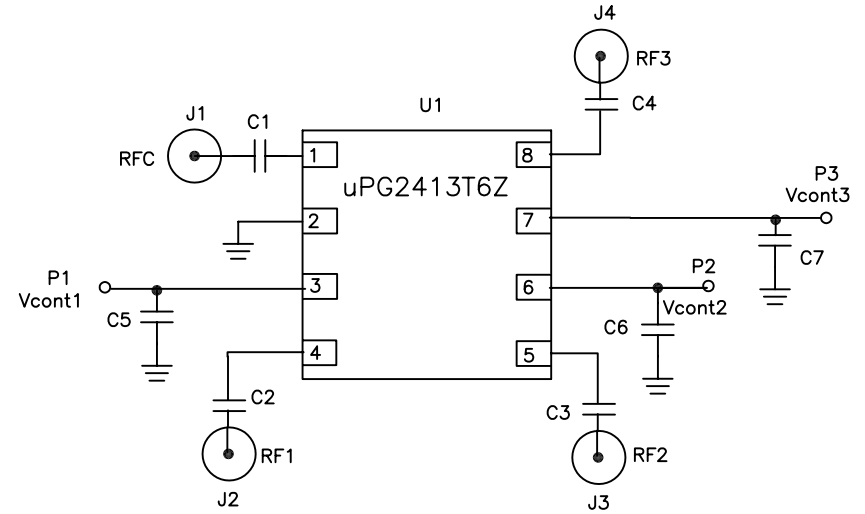
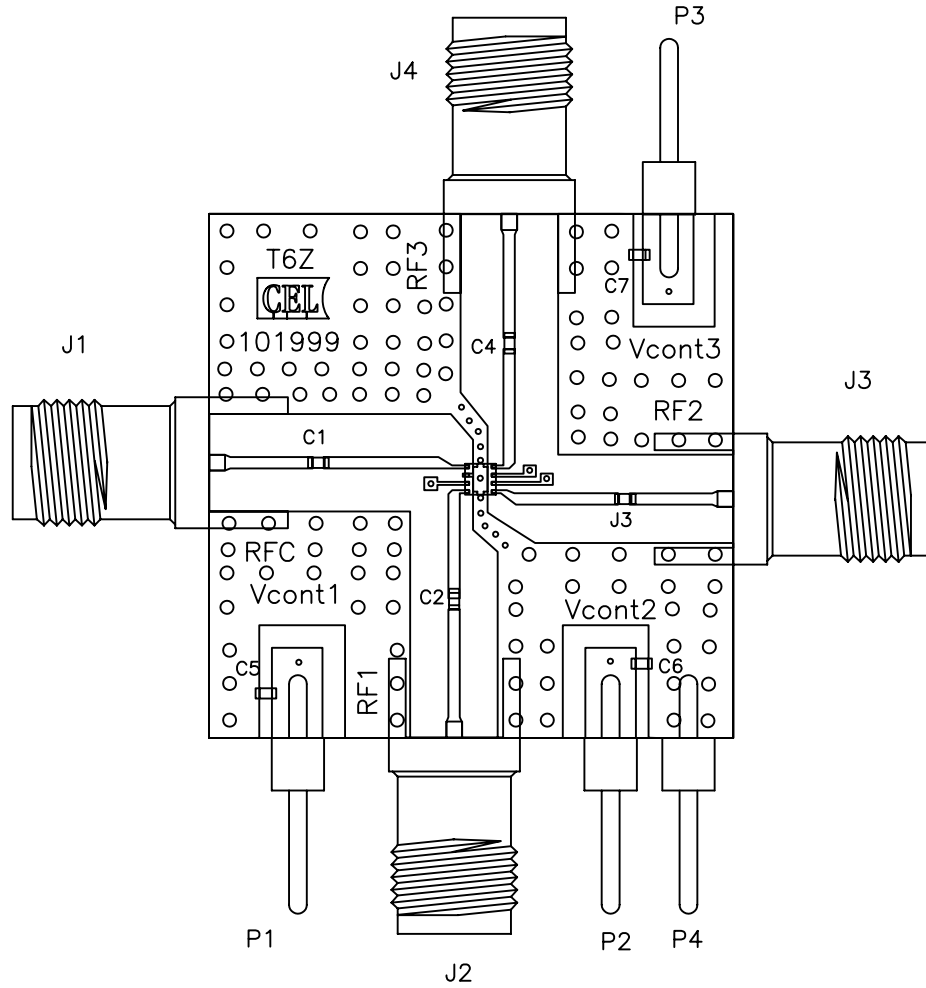

QTY	PART NUMBER OR IDENTIFYING NO.	NOMENCLATURE OR DESCRIPTION	MATERIAL/SPECIFICATION	ITEM NO.
3	GRM1555C1H1102JA01D	C5,C6,C7	0402 1000pF CAP MURATA	6
4	GRM1555C1H560JZ01D	C1,C2,C3,C4	0402 56pF CAP MURATA	5
3	2340-6111 TG	P1,P2,P3,P4	PIN HEADER 3M	4
4	142-0711-821	J1,J2,J3,J4	SMA FEMALE CONNECTOR E.F. JOHNSON	3
1	uPG2413T6Z	U1	NEC uPG2413T6Z	2
1	CL-101999	DRAWING	COMPONENT LAYOUT DRAWING	1

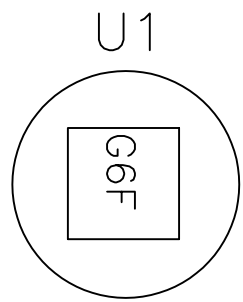

UNLESS OTHERWISE SPECIFIED DIMENSIONS ARE IN INCHES	
DECIMALS	ANGULAR
.XX± .01	± 1°
.XXX± .005	
DO NOT SCALE DRAWING	
MATERIAL	
FINISH	
NEXT ASSY	USED ON
APPLICATION	

APPROVALS	
Drawing by: M Dong	12/8/2009
Designed by: M Dong	12/08/2009
Checked by:	
Project Engineer:	
Quality Control:	

CALIFORNIA EASTERN LABS 4590 PATRICK HENRY DR. SANTA CLARA CA. 95054			
TITLE: uPG2413T6Z-EVAL-A ASSEMBLY DRAWING			
SIZE C	FSCM NO.	DWG NO. AD-101999	REV -
SCALE	RELEASE DATE	PROTOTYPE	SHEET 1 OF 1

Данный компонент на территории Российской Федерации

Вы можете приобрести в компании MosChip.

Для оперативного оформления запроса Вам необходимо перейти по данной ссылке:

<http://moschip.ru/get-element>

Вы можете разместить у нас заказ для любого Вашего проекта, будь то серийное производство или разработка единичного прибора.

В нашем ассортименте представлены ведущие мировые производители активных и пассивных электронных компонентов.

Нашей специализацией является поставка электронной компонентной базы двойного назначения, продукции таких производителей как XILINX, Intel (ex.ALTERA), Vicor, Microchip, Texas Instruments, Analog Devices, Mini-Circuits, Amphenol, Glenair.

Сотрудничество с глобальными дистрибьюторами электронных компонентов, предоставляет возможность заказывать и получать с международных складов практически любой перечень компонентов в оптимальные для Вас сроки.

На всех этапах разработки и производства наши партнеры могут получить квалифицированную поддержку опытных инженеров.

Система менеджмента качества компании отвечает требованиям в соответствии с ГОСТ Р ИСО 9001, ГОСТ РВ 0015-002 и ЭС РД 009

Офис по работе с юридическими лицами:

105318, г.Москва, ул.Щербаковская д.3, офис 1107, 1118, ДЦ «Щербаковский»

Телефон: +7 495 668-12-70 (многоканальный)

Факс: +7 495 668-12-70 (доб.304)

E-mail: info@moschip.ru

Skype отдела продаж:

moschip.ru

moschip.ru_4

moschip.ru_6

moschip.ru_9