



Programmable USB Port Power Controller with Charger Emulation

PRODUCT FEATURES

Data Brief

General Description

The UCS1002 provides a USB port power switch for precise control of up to 2.5 amperes continuous current with over-current limit (OCL), dynamic thermal management, latch or auto-recovery (low test current) fault handling, selectable active low or high enable, under- and over-voltage lockout, back-drive protection, and back-voltage protection.

Split supply support for VS and VDD is an option for low power in system standby states. This gives battery operated applications, like notebook PCs, the ability to detect attachments from a sleep or off state. After the Attach Detection is flagged, the system can decide to wake up and/or provide charging.

In addition to power switching and current limiting modes, the UCS1002 will automatically charge a wide variety of portable devices, including USB-IF BC1.2, YD/T-1591 (2009), most Apple[®] and RIM[®], and many others. Nine preloaded charger emulation profiles maximize compatibility coverage of peripheral devices. As well, a customizable charger emulation profile is available to accommodate unique existing and future portable device handshaking / signature requirements.

The UCS1002 also provides current monitoring to allow intelligent management of system power and charge rationing for controlled delivery of current regardless of the host power state. This is especially important for battery operated applications that want to provide power in a standby and/or off state but do not want to drain the battery excessively.

The UCS1002 is available in a 20-pin QFN 4 mm x 4 mm package.

Applications

- Notebook and Netbook Computers
- Tablets and E-book readers
- Desktops and Monitors
- Docking Stations and Printers
- AC-DC wall adapters

Features

- Port power switch with two current limit behaviors
 - 2.9 V to 5.5 V source voltage range
 - Up to 2.5 A current with 55 mΩ On Resistance
 - Over-current trip or constant current limiting
 - Soft turn-on circuitry
 - Programmable current limit
 - Dynamic thermal management
 - Under- and over-voltage lockout
 - Back-drive, back-voltage protection
 - Latch or auto-recovery (low test current) fault handling
 - Selectable active high or low power switch enable
 - BC1.2 VBUS discharge port renegotiation function
- Selectable / automatic cycling of USB data line charger emulation profiles
 - USB-IF BC1.2 charging downstream port (CDP) & dedicated charging port (DCP) modes, YD/T-1591, and most Apple and RIM protocols standard; others as defined via the SMBus 2.0 / I²C[®]
 - USB 2.0 compliant high-speed data switch (in Pass-through and CDP modes)
 - Nine preloaded charger emulation profiles for maximum compatibility coverage of peripheral devices
 - One custom programmable charger emulation profile for portable device support for fully host controlled charger emulation
- Self-contained current monitoring and charge rationing for power allocation applications
- Automatic shutdown when Battery Full option
- Low power Attach Detection and open-drain A_DET# pin
- Ultra low power Sleep state
- Optional split supply support for VBUS and VDD for low power in system standby states
- Wake on Attach USB
- SMBus 2.0 / I²C communications
 - Supports Block Write and Read
 - Multiple SMBus addresses
- Wide operating temperature range: -40 °C to +85 °C
- IEC61000-4-2 8 / 15 kV ESD immunity
- UL recognized and EN/IEC 60950-1 (CB) certified

Ordering Information

ORDERING NUMBER	PACKAGE	FEATURES
UCS1002-1-BP-TR	20 pin QFN 4 mm x 4 mm (Lead Free RoHS compliant)	USB Port Power Controller with Charger Emulation, Attachment Detection, Current Monitoring, Current Rationing, Programmable SMBus address

REEL SIZE IS 4,000 PIECES

This product meets the halogen maximum concentration values per IEC61249-2-21

For RoHS compliance and environmental information, please visit www.smSC.com/rohs



Copyright © 2012 SMSC or its subsidiaries. All rights reserved.

Circuit diagrams and other information relating to SMSC products are included as a means of illustrating typical applications. Consequently, complete information sufficient for construction purposes is not necessarily given. Although the information has been checked and is believed to be accurate, no responsibility is assumed for inaccuracies. SMSC reserves the right to make changes to specifications and product descriptions at any time without notice. Contact your local SMSC sales office to obtain the latest specifications before placing your product order. The provision of this information does not convey to the purchaser of the described semiconductor devices any licenses under any patent rights or other intellectual property rights of SMSC or others. All sales are expressly conditional on your agreement to the terms and conditions of the most recently dated version of SMSC's standard Terms of Sale Agreement dated before the date of your order (the "Terms of Sale Agreement"). The product may contain design defects or errors known as anomalies which may cause the product's functions to deviate from published specifications. Anomaly sheets are available upon request. SMSC products are not designed, intended, authorized or warranted for use in any life support or other application where product failure could cause or contribute to personal injury or severe property damage. Any and all such uses without prior written approval of an Officer of SMSC and further testing and/or modification will be fully at the risk of the customer. Copies of this document or other SMSC literature, as well as the Terms of Sale Agreement, may be obtained by visiting SMSC's website at <http://www.smSC.com>. SMSC is a registered trademark of Standard Microsystems Corporation ("SMSC"). Product names and company names are the trademarks of their respective holders.

SMSC DISCLAIMS AND EXCLUDES ANY AND ALL WARRANTIES, INCLUDING WITHOUT LIMITATION ANY AND ALL IMPLIED WARRANTIES OF MERCHANTABILITY, FITNESS FOR A PARTICULAR PURPOSE, TITLE, AND AGAINST INFRINGEMENT AND THE LIKE, AND ANY AND ALL WARRANTIES ARISING FROM ANY COURSE OF DEALING OR USAGE OF TRADE. IN NO EVENT SHALL SMSC BE LIABLE FOR ANY DIRECT, INCIDENTAL, INDIRECT, SPECIAL, PUNITIVE, OR CONSEQUENTIAL DAMAGES; OR FOR LOST DATA, PROFITS, SAVINGS OR REVENUES OF ANY KIND; REGARDLESS OF THE FORM OF ACTION, WHETHER BASED ON CONTRACT; TORT; NEGLIGENCE OF SMSC OR OTHERS; STRICT LIABILITY; BREACH OF WARRANTY; OR OTHERWISE; WHETHER OR NOT ANY REMEDY OF BUYER IS HELD TO HAVE FAILED OF ITS ESSENTIAL PURPOSE, AND WHETHER OR NOT SMSC HAS BEEN ADVISED OF THE POSSIBILITY OF SUCH DAMAGES.

Block Diagram

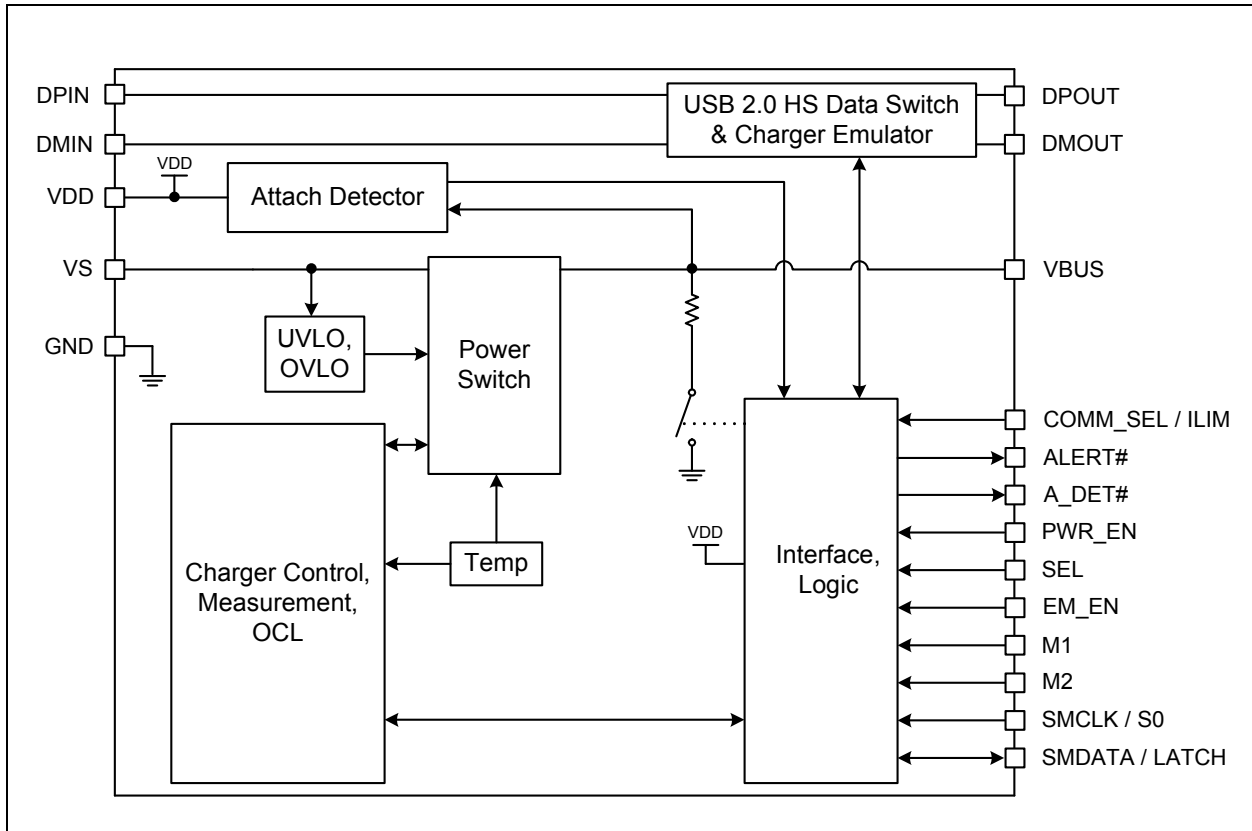

Figure 1 UCS1002 Block Diagram

Package Outline

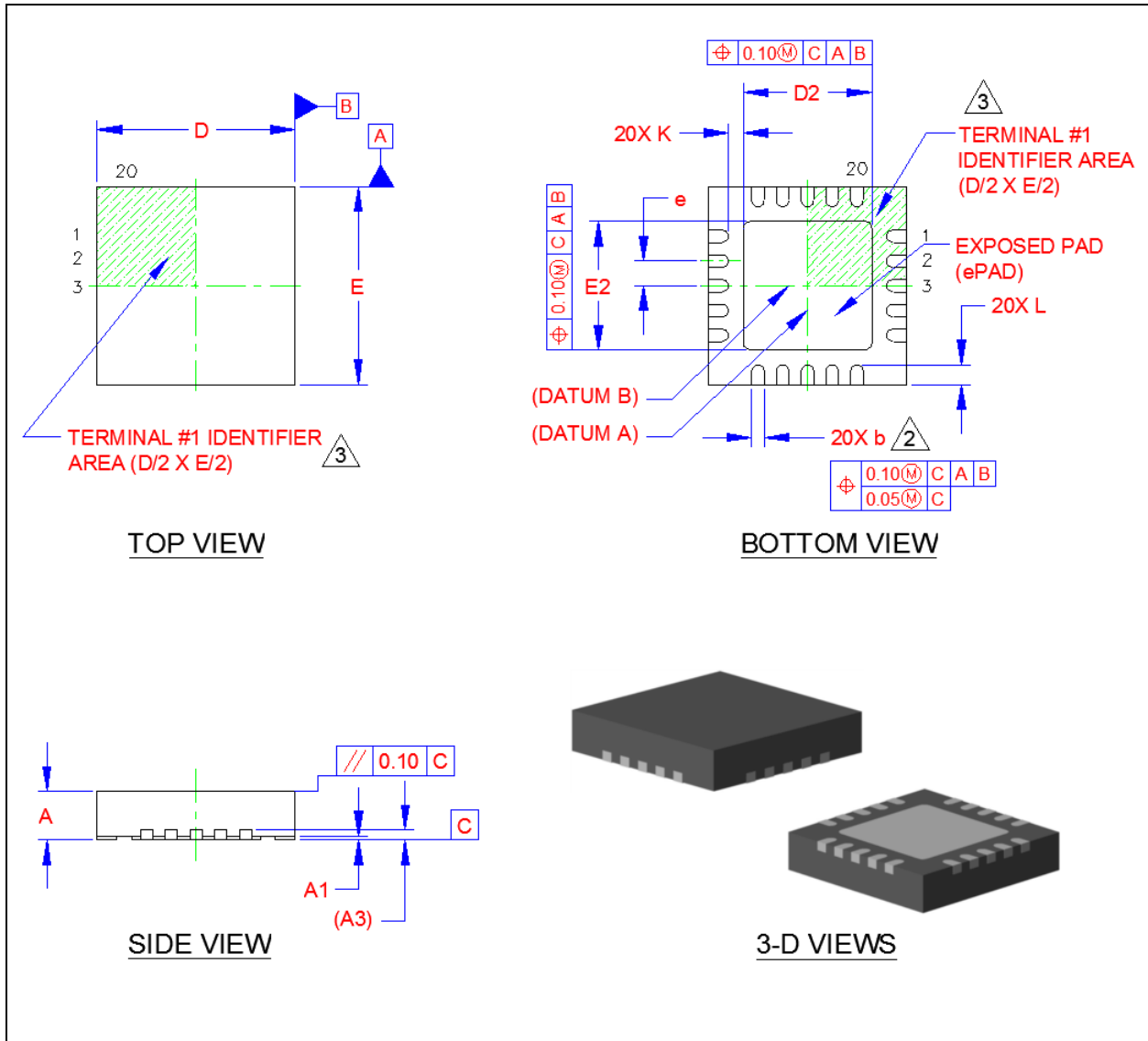

Figure 2 UCS1002 20-pin QFN Package Outline, 4 mm x 4 mm

COMMON DIMENSIONS					
SYMBOL	MIN	NOM	MAX	NOTE	REMARK
A	0.80	0.85	0.90	-	OVERALL PACKAGE HEIGHT
A1	0	0.02	0.05	-	STANDOFF
A3	0.20 REF			-	LEAD-FRAME THICKNESS
D/E	3.90	4.00	4.10	-	X/Y BODY SIZE
D2/E2	2.50	2.60	2.70	-	X/Y EXPOSED PAD SIZE
L	0.30	0.40	0.50	-	TERMINAL LENGTH
b	0.18	0.25	0.30	2	TERMINAL WIDTH
K	0.25	0.30	-	-	TERMINAL TO PAD DISTANCE
e	0.50 BSC			-	TERMINAL PITCH

NOTES:

1. ALL DIMENSIONS ARE IN MILLIMETERS.
2. DIMENSIONS "b" APPLIES TO PLATED TERMINALS AND IT IS MEASURED BETWEEN 0.15 AND 0.30 mm FROM THE TERMINAL TIP.
3. DETAILS OF TERMINAL #1 IDENTIFIER ARE OPTIONAL BUT MUST BE LOCATED WITHIN THE AREA INDICATED.

Figure 3 UCS1002 Package Parameters

Mouser Electronics

Authorized Distributor

Click to View Pricing, Inventory, Delivery & Lifecycle Information:

[Microchip:](#)

[ADM00497](#)

Данный компонент на территории Российской Федерации

Вы можете приобрести в компании MosChip.

Для оперативного оформления запроса Вам необходимо перейти по данной ссылке:

<http://moschip.ru/get-element>

Вы можете разместить у нас заказ для любого Вашего проекта, будь то серийное производство или разработка единичного прибора.

В нашем ассортименте представлены ведущие мировые производители активных и пассивных электронных компонентов.

Нашей специализацией является поставка электронной компонентной базы двойного назначения, продукции таких производителей как XILINX, Intel (ex.ALTERA), Vicor, Microchip, Texas Instruments, Analog Devices, Mini-Circuits, Amphenol, Glenair.

Сотрудничество с глобальными дистрибьюторами электронных компонентов, предоставляет возможность заказывать и получать с международных складов практически любой перечень компонентов в оптимальные для Вас сроки.

На всех этапах разработки и производства наши партнеры могут получить квалифицированную поддержку опытных инженеров.

Система менеджмента качества компании отвечает требованиям в соответствии с ГОСТ Р ИСО 9001, ГОСТ РВ 0015-002 и ЭС РД 009

Офис по работе с юридическими лицами:

105318, г.Москва, ул.Щербаковская д.3, офис 1107, 1118, ДЦ «Щербаковский»

Телефон: +7 495 668-12-70 (многоканальный)

Факс: +7 495 668-12-70 (доб.304)

E-mail: info@moschip.ru

Skype отдела продаж:

moschip.ru

moschip.ru_4

moschip.ru_6

moschip.ru_9