

ESD Protection for high speed interface

Main applications

Where transient over-voltage protection in ESD sensitive equipment is required, such as:

- Computers
- Printers
- Communication systems
- Cell phone handsets and accessories
- Video equipment

Description

The **DSILC6-4xx** is a monolithic application specific discrete dedicated to ESD protection of high speed interfaces, such as USB 2.0, Ethernet, **display and camera serial interfaces (LVDS)**.

The device is ideal for applications where both reduced printed circuit board space and power absorption capability are required.

Features

Diode array topology

- 4 line protection
- 5 V V_{CC} protection
- Very low capacitance: 1 pF typ.
- Lead-free package
- RoHS compliant

Benefits

- Very low capacitance between lines to GND for optimized data integrity
- Low PCB space consumption: 2.9 mm² max for SOT-666 and 1.5 mm² max for Flip-Chip
- Cut-off frequency > 2 GHz
- High reliability offered by monolithic integration
- MDDI, SMIA, MIPI specification compliant

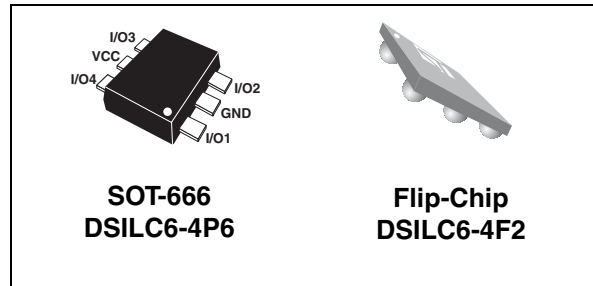

Functional diagram

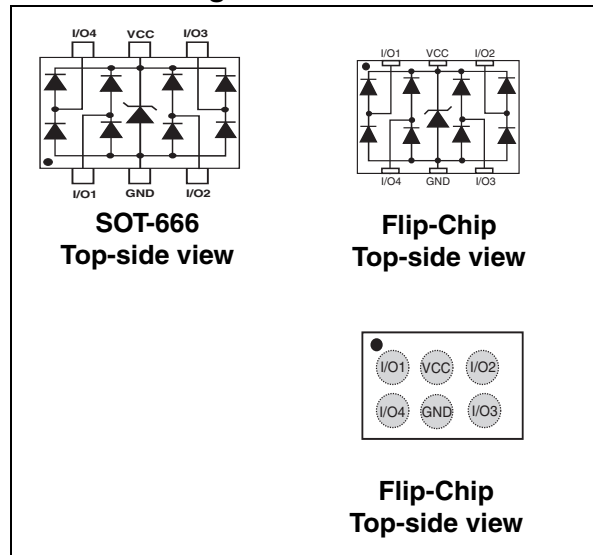

Order Code

Part Number	Marking
DSILC6-4P6	G
DSILC6-4F2	EI

Complies with the following standards:

IEC 61000-4-2 level 4:

8 kV (contact discharge)

15 kV (air discharge)

MIL STD 883G-Method 3015-7: class 3B

1 Characteristics

Table 1. Absolute ratings

Symbol	Parameter		Value	Unit
V _{PP}	Peak pulse voltage	IEC 61000-4-2 contact discharge IEC 61000-4-2 air discharge	8 15	kV
I _{PP}	Peak pulse current	I/O to GND Pulse waveform = 8/20 μs	SOT-666 5	A
			Flip-Chip 7	
P _{PP}	Peak pulse power		SOT-666 90 Flip-Chip 120	W
T _{stg}	Storage temperature range		-55 to +150	°C
T _j	Maximum junction temperature		125	°C
T _L	Lead solder temperature (10 seconds duration)		260	°C

Table 2. Electrical characteristics (T_{amb} = 25° C)

Symbol	Parameter
V _{RM}	Reverse stand-off voltage
I _{RM}	Leakage current
V _{BR}	Breakdown voltage
V _F	Forward voltage
V _{CL}	Clamping voltage
I _{PP}	Peak pulse current

Symbol	Parameter	Test Conditions	Value			Unit	
			Min	Typ	Max		
I _{RM}	Leakage current	V _{RM} = 5 V			0.5	μA	
V _{BR}	Breakdown voltage between V _{BUS} and GND	I _R = 1 mA	6			V	
V _F	Forward voltage	I _F = 10 mA			1	V	
C _{i/o-GND}	Capacitance between I/O and GND	V _{I/O} = 0 V, F = 1 MHz, V _{OSC} = 30 mV	SOT-666		2	2.5	pF
			Flip-Chip		2.5	3	
		V _{I/O} = 1.65 V, V _{CC} = 4.3 V, F = 1 MHz, V _{OSC} = 400 mV	SOT-666		1.5	1.8	
			Flip-Chip		1.8	2.0	
C _{i/o-i/o}	Capacitance between I/O	V _{I/O} = 0 V, F = 1 MHz, V _{OSC} = 30 mV	SOT-666		1.0	1.25	
			Flip-Chip		1.25	1.5	
		V _{I/O} = 1.65 V, V _{CC} = 4.3 V, F = 1 MHz, V _{OSC} = 400 mV	SOT-666		0.75	0.9	
			Flip-Chip		0.9	1.20	
ΔC _{i/o-GND}		V _{I/O} = 0 V, F = 1 MHz, V _{OSC} = 30 mV			0.06		
ΔC _{i/o-i/o}		V _{I/O} = 0 V, F = 1 MHz, V _{OSC} = 30 mV			0.05		

Figure 1. Relative variation of leakage current versus junction temperature - SOT-666 (typical values)

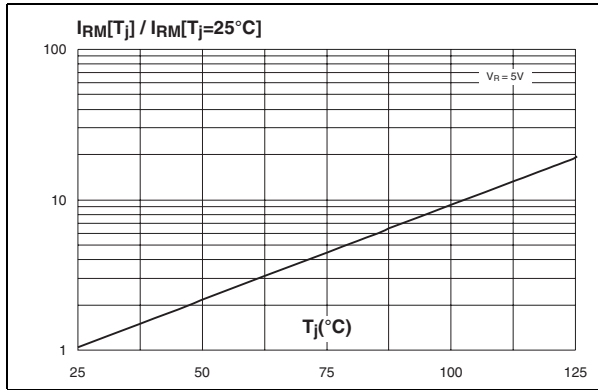

Figure 2. Relative variation of leakage current versus junction temperature Flip-Chip (typical values)

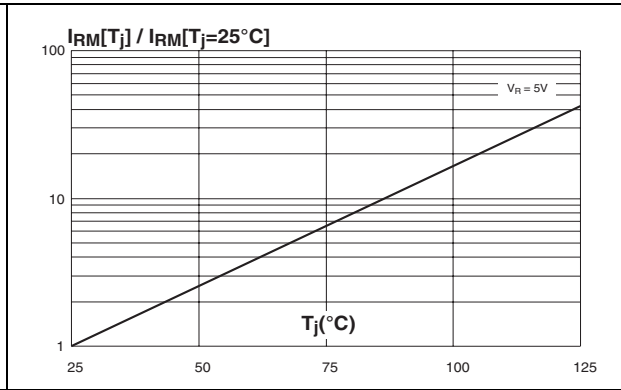

Figure 3. Remaining voltage after DSILC6-4P6 during ESD 15 kV positive surge (air discharge)

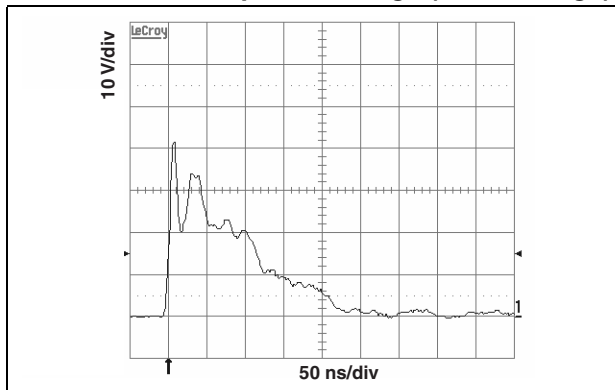

Figure 4. Remaining voltage after DSILC6-4F2 during ESD 15 kV positive surge (air discharge)

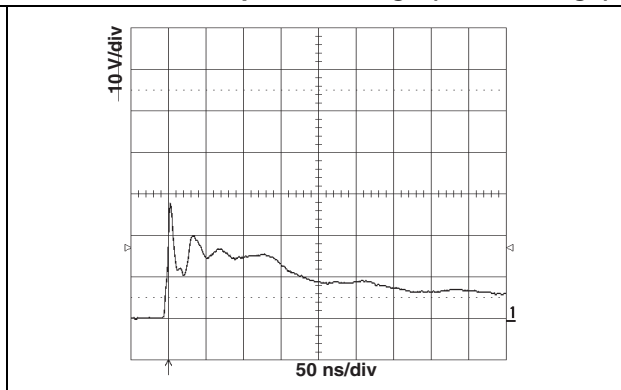

Figure 5. Remaining voltage after DSILC6-4P6 during ESD 15 kV negative surge (air discharge)

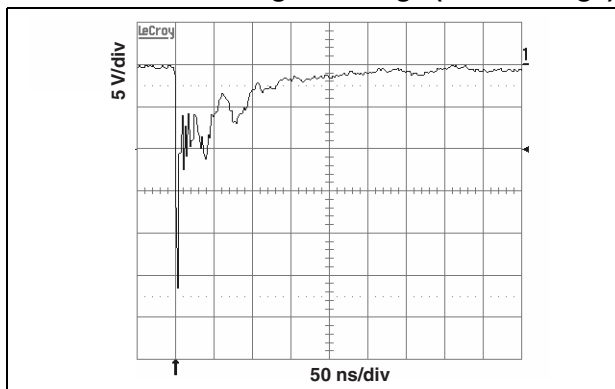

Figure 6. Remaining voltage after DSILC6-4F2 during ESD 15 kV negative surge (air discharge)

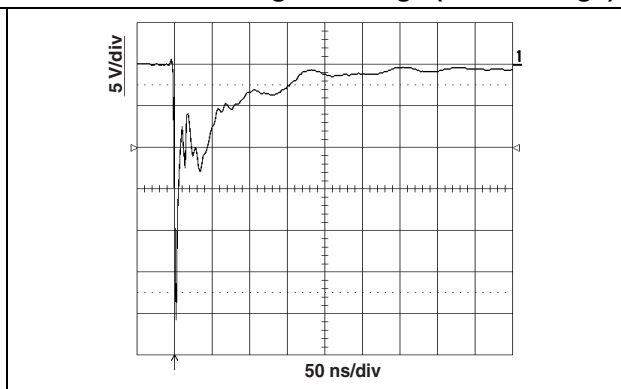

Figure 7. Frequency responses of all lines DSILC6-4P6

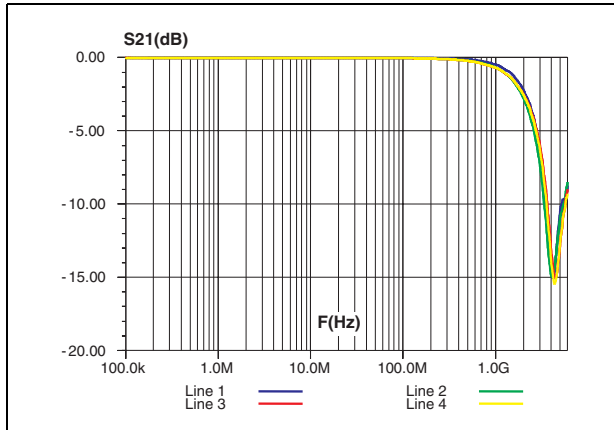

Figure 8. Frequency response of all lines DSILC6-4F2

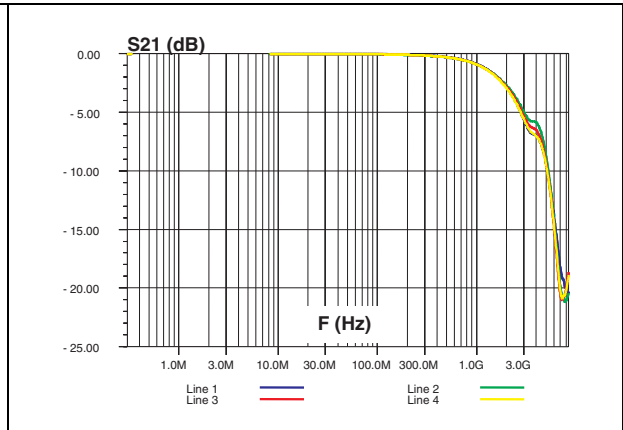

Figure 9. Crosstalk results for lines 1/2 and 1/3 DSILC6-4P6

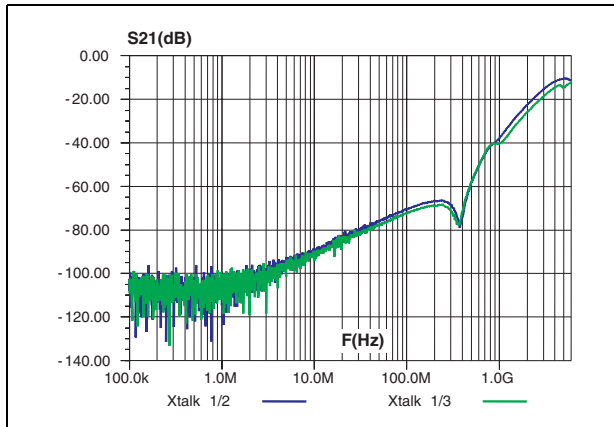
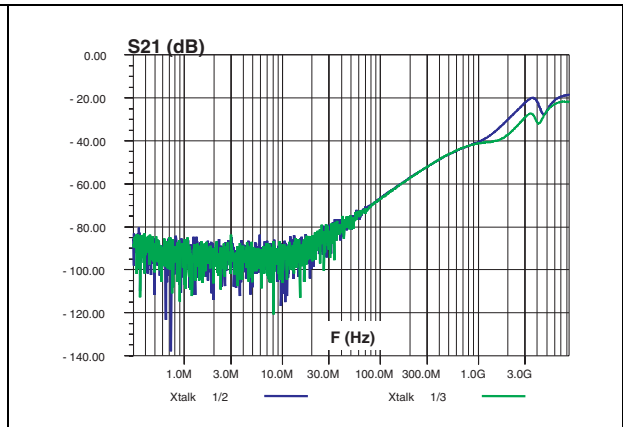
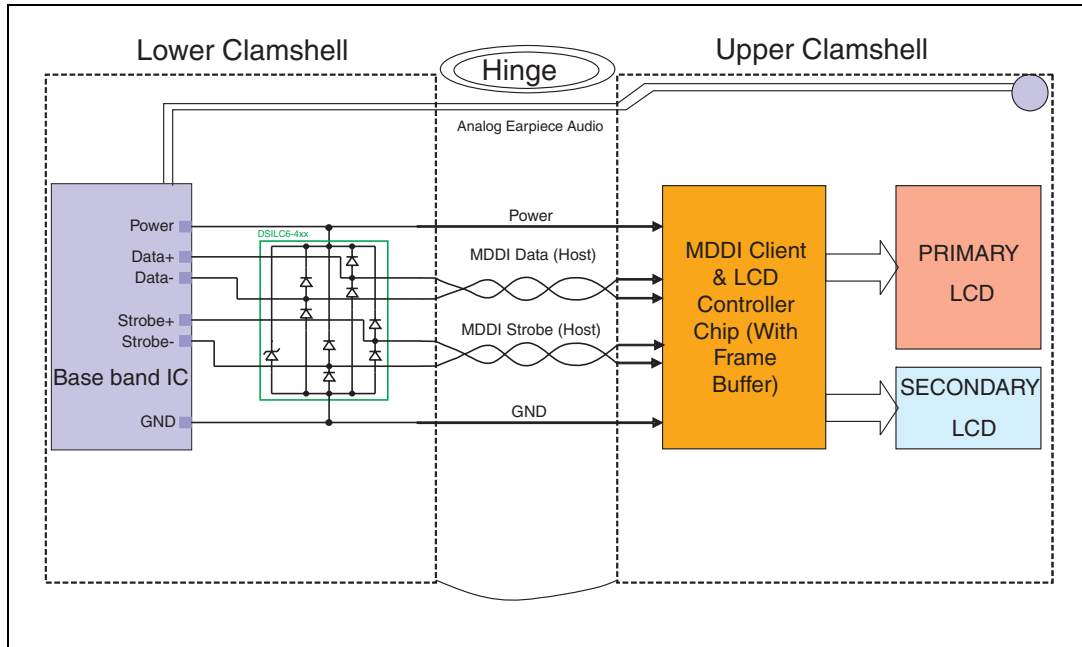

Figure 10. Crosstalk results for lines 1/2 and 1/3 DSILC6-4F2



2 Application examples

2.1 MDDI



2.2 SMIA

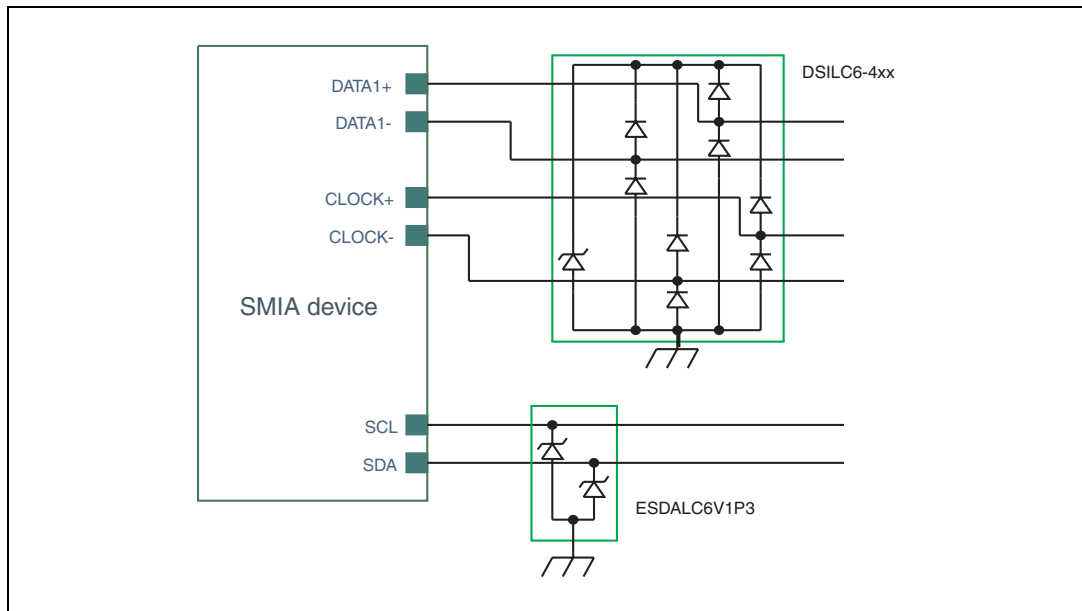

2.3 Ethernet 1 Gb

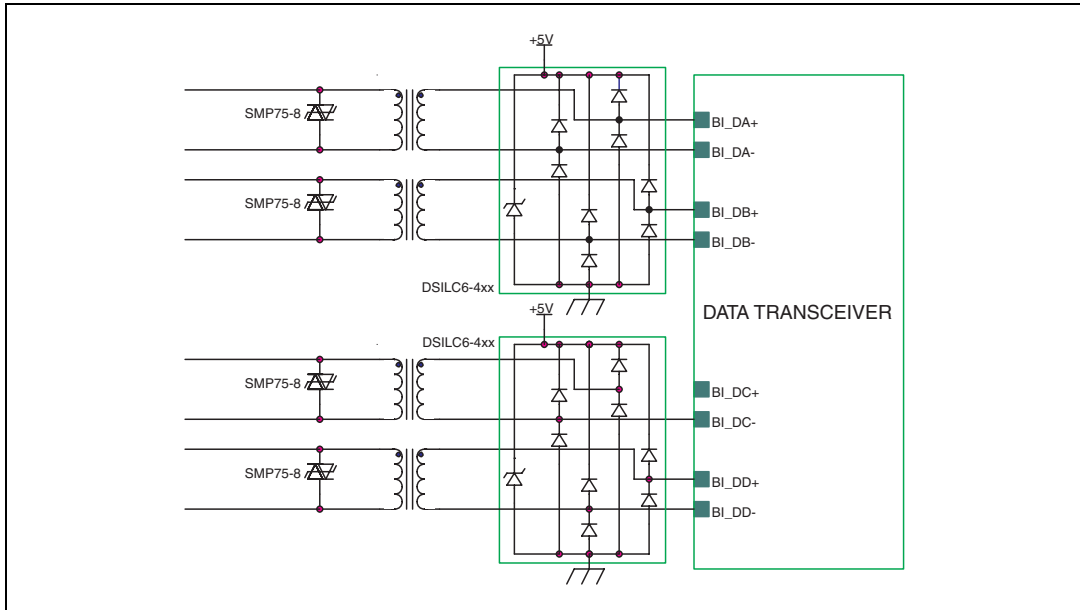

2.4 USB 2.0

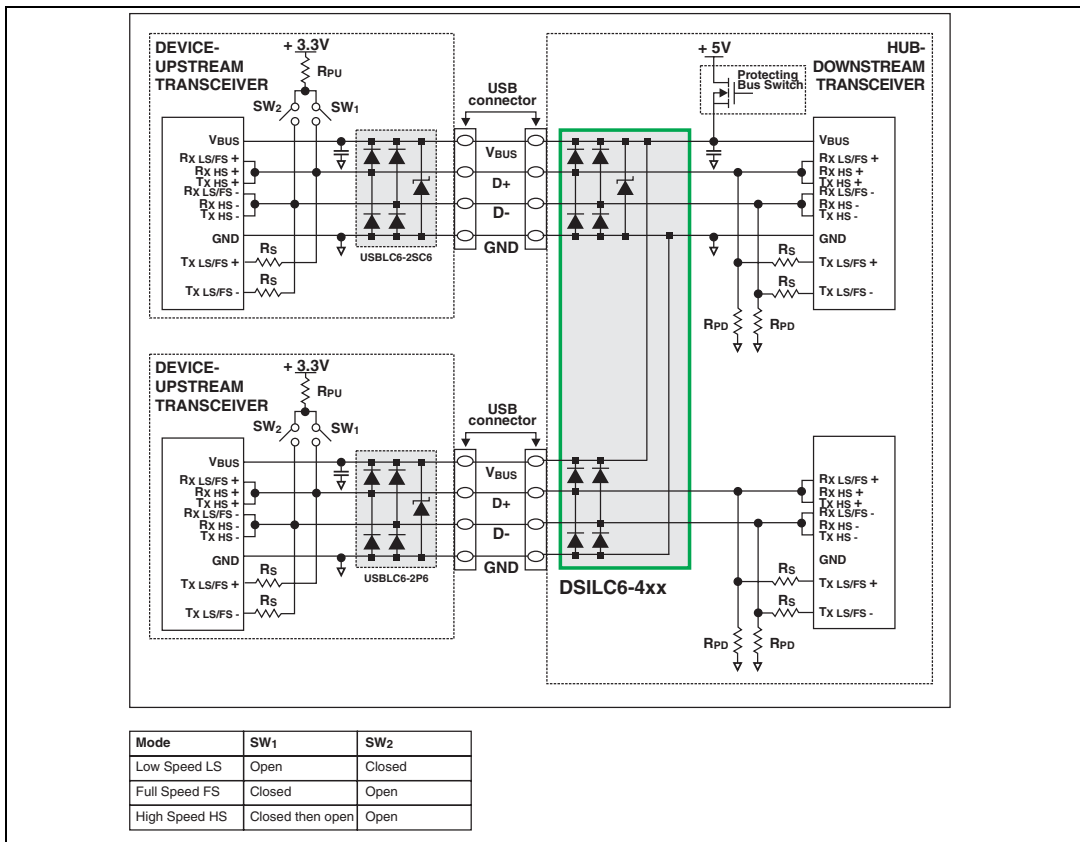

3 Ordering information scheme

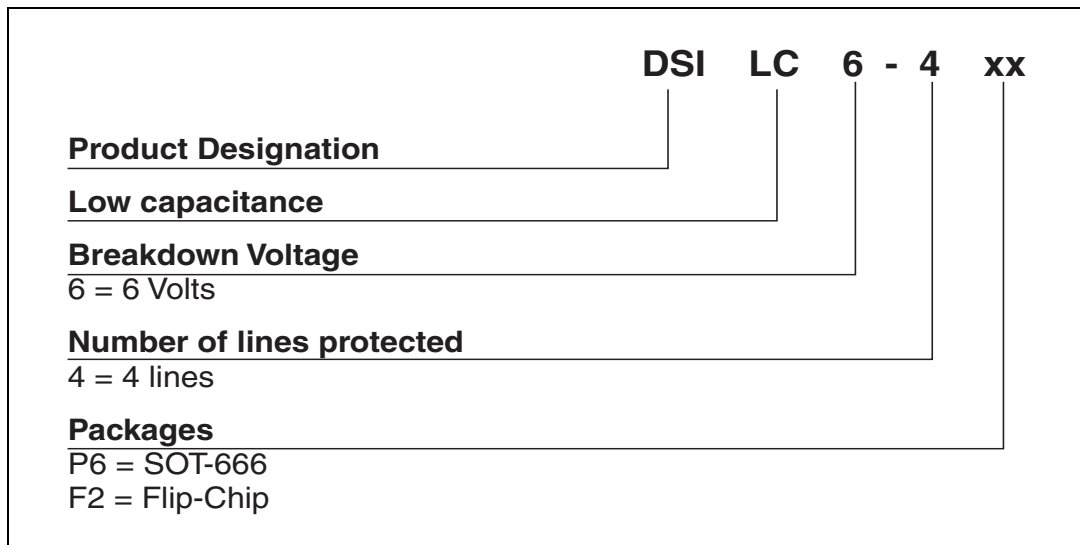

4 Package information

- Epoxy meets UL94, V0

Table 3. SOT-666 Dimensions

Ref.	Dimensions					
	Millimeters			Inches		
	Min.	Typ.	Max.	Min.	Typ.	Max.
A	0.45		0.60	0.018		0.024
A3	0.08		0.18	0.003		0.007
b	0.17		0.34	0.007		0.013
b1	0.19	0.27	0.34	0.007	0.011	0.013
D	1.50		1.70	0.059		0.067
E	1.50		1.70	0.059		0.067
E1	1.10		1.30	0.043		0.051
e		0.50			0.020	
L1		0.19			0.007	
L2	0.10		0.30	0.004		0.012
L3		0.10			0.004	

Figure 11. SOT-666 footprint

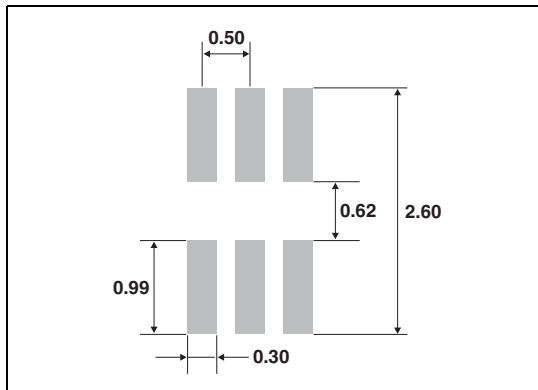

Figure 12. SOT-666 marking

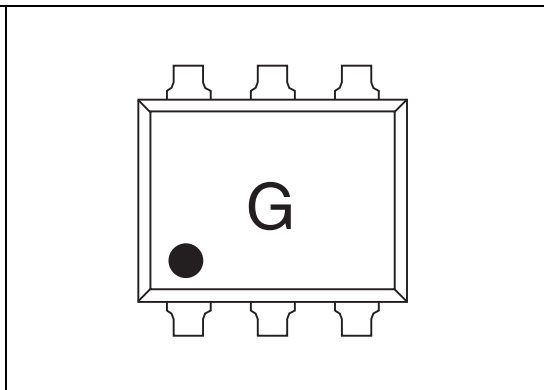

Figure 13. Flip-Chip Dimensions

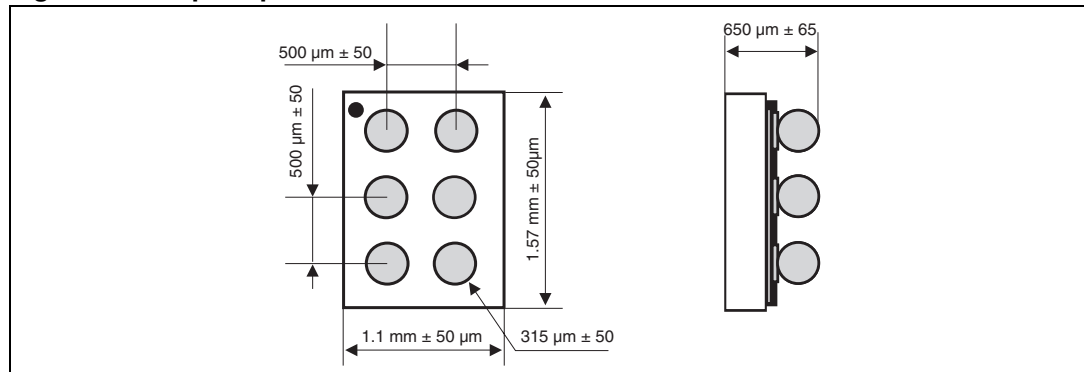

Figure 14. Flip-Chip footprint

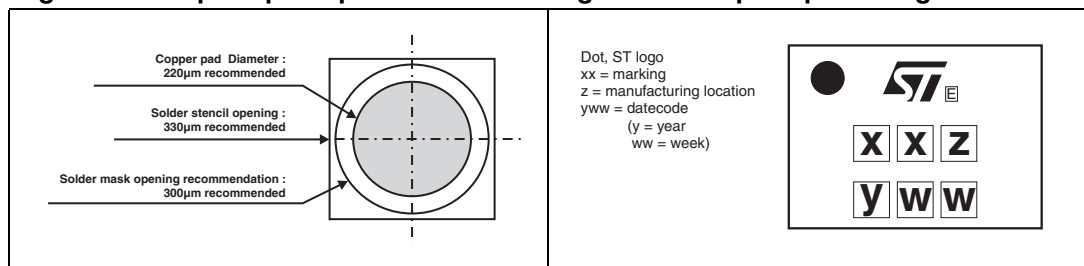

Figure 15. Flip-Chip marking

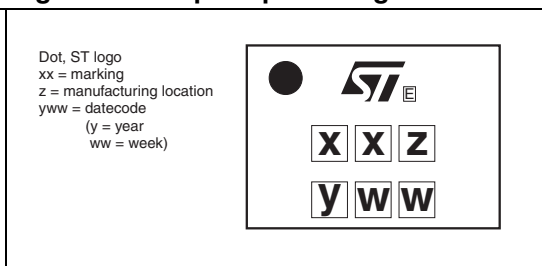
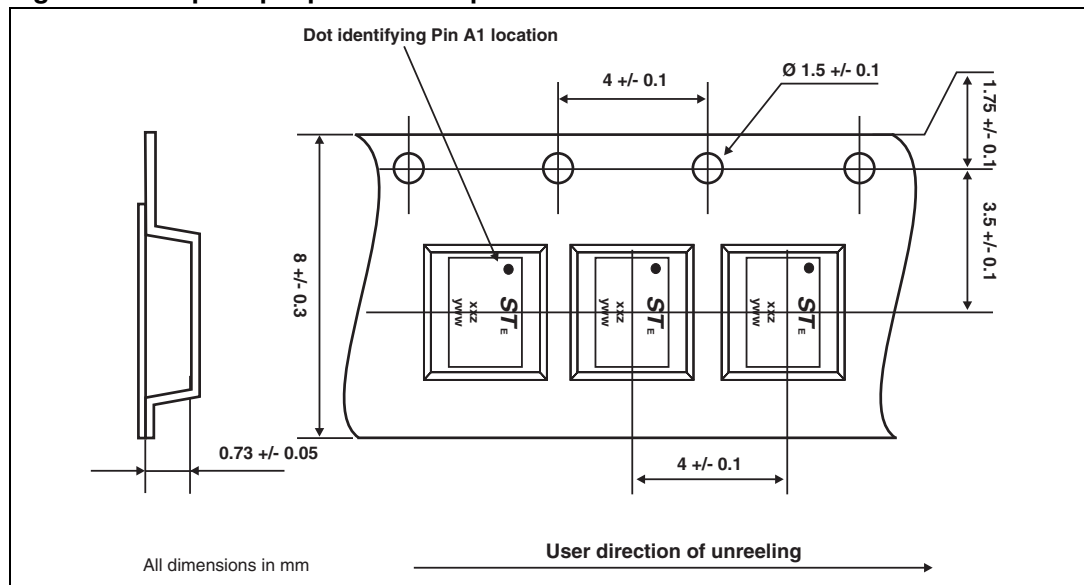

Figure 16. Flip-Chip tape and reel specifications



In order to meet environmental requirements, ST offers these devices in ECOPACK® packages. These packages have a lead-free second level interconnect. The category of second level interconnect is marked on the inner box label, in compliance with JEDEC Standard JESD97. The maximum ratings related to soldering conditions are also marked on the inner box label. ECOPACK is an ST trademark. ECOPACK specifications are available at: www.st.com.

5 Ordering information

Ordering code	Marking	Package	Weight	Base qty	Delivery mode
DSILC6-4P6	G	SOT-666	2.9 mg	3000	Tape and reel
DSILC6-4F2	EI	Flip-Chip	2.22 mg	5000	Tape and reel

6 Revision history

Date	Revision	Description of Changes
10-Aug-2006	1	Initial release.
04-Jan-2007	2	Added Flip-Chip package. Added applications examples for SMIA, Ethernet 1 Gb, and USB. Updated Tj max to 150. Added V _{RM} line in Table 2. Modified MDDI example figure.
28-May-2007	3	Modified Functional diagram on page 1 to show Top side view instead of Bump side view of DSILC64F2. Removed V _{RM} line in Table 2. Added characteristic curves specific to each package for ESD, Frequency response and Crosstalk

Please Read Carefully:

Information in this document is provided solely in connection with ST products. STMicroelectronics NV and its subsidiaries ("ST") reserve the right to make changes, corrections, modifications or improvements, to this document, and the products and services described herein at any time, without notice.

All ST products are sold pursuant to ST's terms and conditions of sale.

Purchasers are solely responsible for the choice, selection and use of the ST products and services described herein, and ST assumes no liability whatsoever relating to the choice, selection or use of the ST products and services described herein.

No license, express or implied, by estoppel or otherwise, to any intellectual property rights is granted under this document. If any part of this document refers to any third party products or services it shall not be deemed a license grant by ST for the use of such third party products or services, or any intellectual property contained therein or considered as a warranty covering the use in any manner whatsoever of such third party products or services or any intellectual property contained therein.

UNLESS OTHERWISE SET FORTH IN ST'S TERMS AND CONDITIONS OF SALE ST DISCLAIMS ANY EXPRESS OR IMPLIED WARRANTY WITH RESPECT TO THE USE AND/OR SALE OF ST PRODUCTS INCLUDING WITHOUT LIMITATION IMPLIED WARRANTIES OF MERCHANTABILITY, FITNESS FOR A PARTICULAR PURPOSE (AND THEIR EQUIVALENTS UNDER THE LAWS OF ANY JURISDICTION), OR INFRINGEMENT OF ANY PATENT, COPYRIGHT OR OTHER INTELLECTUAL PROPERTY RIGHT.

UNLESS EXPRESSLY APPROVED IN WRITING BY AN AUTHORIZED ST REPRESENTATIVE, ST PRODUCTS ARE NOT RECOMMENDED, AUTHORIZED OR WARRANTED FOR USE IN MILITARY, AIR CRAFT, SPACE, LIFE SAVING, OR LIFE SUSTAINING APPLICATIONS, NOR IN PRODUCTS OR SYSTEMS WHERE FAILURE OR MALFUNCTION MAY RESULT IN PERSONAL INJURY, DEATH, OR SEVERE PROPERTY OR ENVIRONMENTAL DAMAGE. ST PRODUCTS WHICH ARE NOT SPECIFIED AS "AUTOMOTIVE GRADE" MAY ONLY BE USED IN AUTOMOTIVE APPLICATIONS AT USER'S OWN RISK.

Resale of ST products with provisions different from the statements and/or technical features set forth in this document shall immediately void any warranty granted by ST for the ST product or service described herein and shall not create or extend in any manner whatsoever, any liability of ST.

ST and the ST logo are trademarks or registered trademarks of ST in various countries.

Information in this document supersedes and replaces all information previously supplied.

The ST logo is a registered trademark of STMicroelectronics. All other names are the property of their respective owners.

© 2007 STMicroelectronics - All rights reserved

STMicroelectronics group of companies

Australia - Belgium - Brazil - Canada - China - Czech Republic - Finland - France - Germany - Hong Kong - India - Israel - Italy - Japan - Malaysia - Malta - Morocco - Singapore - Spain - Sweden - Switzerland - United Kingdom - United States of America

www.st.com

Данный компонент на территории Российской Федерации

Вы можете приобрести в компании MosChip.

Для оперативного оформления запроса Вам необходимо перейти по данной ссылке:

<http://moschip.ru/get-element>

Вы можете разместить у нас заказ для любого Вашего проекта, будь то серийное производство или разработка единичного прибора.

В нашем ассортименте представлены ведущие мировые производители активных и пассивных электронных компонентов.

Нашей специализацией является поставка электронной компонентной базы двойного назначения, продукции таких производителей как XILINX, Intel (ex.ALTERA), Vicor, Microchip, Texas Instruments, Analog Devices, Mini-Circuits, Amphenol, Glenair.

Сотрудничество с глобальными дистрибьюторами электронных компонентов, предоставляет возможность заказывать и получать с международных складов практически любой перечень компонентов в оптимальные для Вас сроки.

На всех этапах разработки и производства наши партнеры могут получить квалифицированную поддержку опытных инженеров.

Система менеджмента качества компании отвечает требованиям в соответствии с ГОСТ Р ИСО 9001, ГОСТ РВ 0015-002 и ЭС РД 009

Офис по работе с юридическими лицами:

105318, г.Москва, ул.Щербаковская д.3, офис 1107, 1118, ДЦ «Щербаковский»

Телефон: +7 495 668-12-70 (многоканальный)

Факс: +7 495 668-12-70 (доб.304)

E-mail: info@moschip.ru

Skype отдела продаж:

moschip.ru

moschip.ru_4

moschip.ru_6

moschip.ru_9