

- Ideal for 318 MHz Remote Control and Wireless Security Transmitters
- Very Low Series Resistance
- Quartz Stability
- Complies with Directive 2002/95/EC (RoHS)



The RO3118D is a true one-port, surface-acoustic-wave (SAW) resonator in a surface-mount ceramic case. It provides reliable, fundamental-mode, quartz frequency stabilization of transmitters and local oscillators operating at 318 MHz.

**Absolute Maximum Ratings**

Rating	Value	Units
Input Power Level	0	dBm
DC Voltage	12	VDC
Storage Temperature	-40 to +85	°C
Soldering Temperature (10 seconds / 5 cycles maximum)	260	°C

**RO3118D**

**318.0 MHz  
SAW  
Resonator**

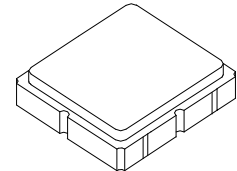

**SM3838-6 Case  
3.8 X 3.8**

**Electrical Characteristics**

Characteristic	Sym	Notes	Minimum	Typical	Maximum	Units	
Frequency, +25 °C	Absolute Frequency	$f_C$	2, 3, 4, 5	317.925		318.075	MHz
	Tolerance from 318.0 MHz	$\Delta f_C$					
Insertion Loss		IL	2, 5, 6		1.4	2.0	dB
Quality Factor	Unloaded Q	$Q_U$			12900		
	50Ω Loaded Q	$Q_L$			1800		
Temperature Stability	Turnover Temperature	$T_O$	6, 7, 8	10	25	40	°C
	Turnover Frequency	$f_O$			$f_C$		
	Frequency Temperature Coefficient	FTC			0.032		ppm/°C <sup>2</sup>
Frequency Aging	Absolute Value during the First Year	$ f_A $	1, 6		10		ppm/yr
DC Insulation Resistance between Any Two Terminals			5	1.0			MΩ
RF Equivalent RLC Model	Motional Resistance	$R_M$	5, 7, 9		16		Ω
	Motional Inductance	$L_M$			101		μH
	Motional Capacitance	$C_M$			2.4		fF
	Shunt Static Capacitance	$C_O$		5, 6, 9	2.8		pF
Test Fixture Shunt Inductance		$L_{TEST}$	2, 7		86		nH
Lid Symbolization		716 // YWWS					
Standard Reel Quantity	Reel Size 7 Inch		500 Pieces / Reel				
	Reel Size 13 Inch		3000 Pieces / Reel				

**CAUTION: Electrostatic Sensitive Device. Observe precautions for handling.**

**NOTES:**

1. Frequency aging is the change in  $f_C$  with time and is specified at +65 °C or less. Aging may exceed the specification for prolonged temperatures above +65 °C. Typically, aging is greatest the first year after manufacture, decreasing in subsequent years.
2. The center frequency,  $f_C$ , is measured at the minimum insertion loss point,  $IL_{MIN}$ , with the resonator in the 50 Ω test system (VSWR ≤ 1.2:1). The shunt inductance,  $L_{TEST}$ , is tuned for parallel resonance with  $C_O$  at  $f_C$ . Typically,  $f_{OSCILLATOR}$  or  $f_{TRANSMITTER}$  is approximately equal to the resonator  $f_C$ .
3. One or more of the following United States patents apply: 4,454,488 and 4,616,197.
4. Typically, equipment utilizing this device requires emissions testing and government approval, which is the responsibility of the equipment manufacturer.
5. Unless noted otherwise, case temperature  $T_C = +25 \pm 2$  °C.
6. The design, manufacturing process, and specifications of this device are subject to change without notice.
7. Derived mathematically from one or more of the following directly measured parameters:  $f_C$ , IL, 3 dB bandwidth,  $f_C$  versus  $T_C$ , and  $C_O$ .
8. Turnover temperature,  $T_O$ , is the temperature of maximum (or turnover) frequency,  $f_O$ . The nominal frequency at any case temperature,  $T_C$ , may be calculated from:  $f = f_O [1 - FTC (T_O - T_C)^2]$ . Typically *oscillator*  $T_O$  is approximately equal to the specified *resonator*  $T_O$ .
9. This equivalent RLC model approximates resonator performance near the resonant frequency and is provided for reference only. The capacitance  $C_O$  is the static (nonmotional) capacitance between the two terminals measured at low frequency (10 MHz) with a capacitance meter. The measurement includes parasitic capacitance with "NC" pads unconnected. Case parasitic capacitance is approximately 0.05 pF. Transducer parallel capacitance can be calculated as:  $C_P \approx C_O - 0.05$  pF.

## Electrical Connections

The SAW resonator is bidirectional and may be installed with either orientation. The two terminals are interchangeable and unnumbered. The callout NC indicates no internal connection. The NC pads assist with mechanical positioning and stability. External grounding of the NC pads is recommended to help reduce parasitic capacitance in the circuit.

Pin	Connection
1	NC
2	Terminal
3	NC
4	NC
5	NC
6	Terminal
7	NC
8	NC

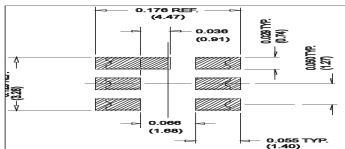
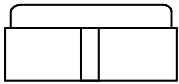
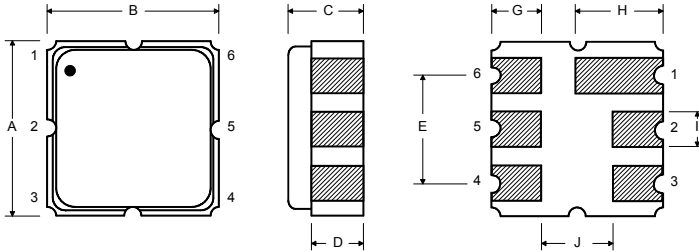

## Case Dimensions

Dimension	mm			Inches		
	Min	Nom	Max	Min	Nom	Max
A	3.60	3.80	4.00	0.142	0.150	0.157
B	3.60	3.80	4.00	0.142	0.150	0.157
C	1.10	1.30	1.50	0.043	0.050	0.060
D	0.95	1.10	1.25	0.037	0.043	0.049
E	2.39	2.54	2.69	0.094	0.100	0.106
G	0.90	1.00	1.10	0.035	0.040	0.043
H	1.90	2.00	2.10	0.748	0.079	0.083
I	0.50	0.60	0.70	0.020	0.024	0.028
J	1.70	1.80	1.90	0.067	0.071	0.075

## Equivalent RLC Model

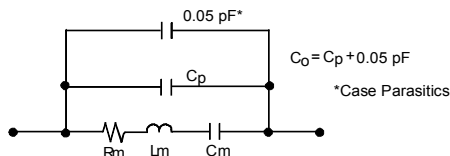

## Parameter Test Circuit

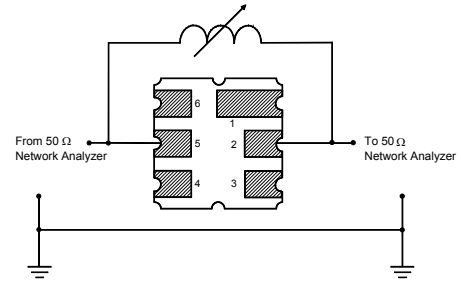

## Power Test Circuit

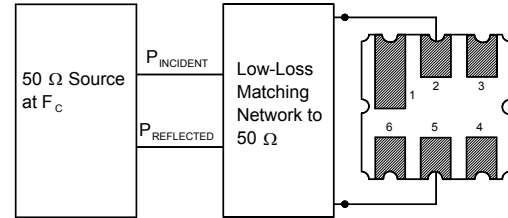

## Example Application Circuits

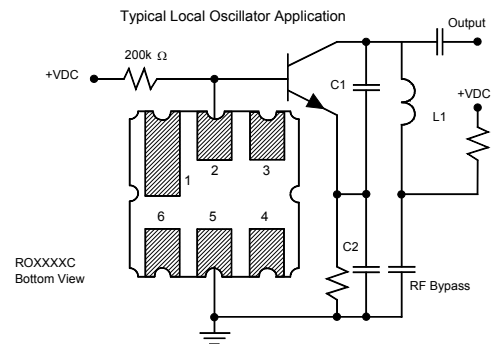
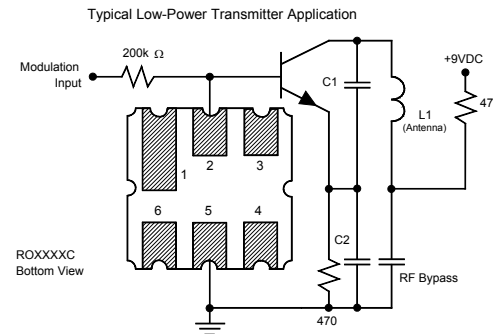

## Temperature Characteristics

The curve shown on the right accounts for resonator contribution only and does not include LC component temperature contributions.

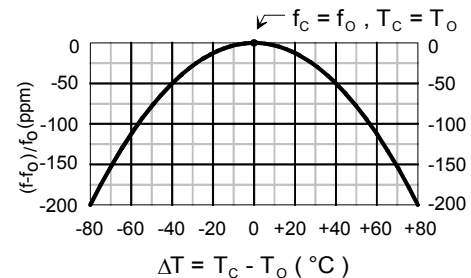

## Данный компонент на территории Российской Федерации

### Вы можете приобрести в компании MosChip.

Для оперативного оформления запроса Вам необходимо перейти по данной ссылке:

<http://moschip.ru/get-element>

Вы можете разместить у нас заказ для любого Вашего проекта, будь то серийное производство или разработка единичного прибора.

В нашем ассортименте представлены ведущие мировые производители активных и пассивных электронных компонентов.

Нашей специализацией является поставка электронной компонентной базы двойного назначения, продукции таких производителей как XILINX, Intel (ex.ALTERA), Vicor, Microchip, Texas Instruments, Analog Devices, Mini-Circuits, Amphenol, Glenair.

Сотрудничество с глобальными дистрибьюторами электронных компонентов, предоставляет возможность заказывать и получать с международных складов практически любой перечень компонентов в оптимальные для Вас сроки.

На всех этапах разработки и производства наши партнеры могут получить квалифицированную поддержку опытных инженеров.

Система менеджмента качества компании отвечает требованиям в соответствии с ГОСТ Р ИСО 9001, ГОСТ РВ 0015-002 и ЭС РД 009

### Офис по работе с юридическими лицами:

105318, г.Москва, ул.Щербаковская д.3, офис 1107, 1118, ДЦ «Щербаковский»

Телефон: +7 495 668-12-70 (многоканальный)

Факс: +7 495 668-12-70 (доб.304)

E-mail: [info@moschip.ru](mailto:info@moschip.ru)

Skype отдела продаж:

moschip.ru

moschip.ru\_4

moschip.ru\_6

moschip.ru\_9