

Certified low-power, low-voltage accelerometer

LPA100T-D2

SPECIFICATIONS

Sensitivity, $\pm 5\%$, 25°C	50 mV/g
Acceleration range	25 g peak
Amplitude nonlinearity	1%
Frequency response:	
$\pm 5\%$	3 - 5,000 Hz
$\pm 10\%$	1 - 9,000 Hz
± 3 dB	0.3 - 15,000 Hz
Resonance frequency	30 kHz
Transverse sensitivity, max	5% of axial
Sensitivity variation with temp:	
-25°C	-10%
+120°C	+10%
Temperature sensor:	
Temperature range	-40°C to +120°C
Voltage range	+2.52 to +0.77 V
Temperature signal sensitivity	-10.9 mV/°C
Voltage at 0°C	+2.1 V
Power requirement:	
Voltage source	3.0 - 5.5 VDC
Current (no cable)	100 μ A, max
Electrical noise, equiv. g:	
Broadband	2.5 Hz to 25 kHz
Spectral	10 Hz
	100 Hz
	1,000 Hz
	660 μ g
	60 μ g/ $\sqrt{\text{Hz}}$
	16 μ g/ $\sqrt{\text{Hz}}$
	5 μ g/ $\sqrt{\text{Hz}}$
Output impedance, max	1,000 Ω
Bias output voltage, settling time, 25°C	<10 ms
Including temp effects	1.5 VDC $\pm 5\%$
Grounding	case isolated, internally shielded
Vibration limit	500 g peak
Shock limit	5,000 g peak
Electromagnetic sensitivity, equiv. g, max	150 μ g/gauss
Sealing	hermetic
Base strain sensitivity, max	0.0002 g/ μ strain
Sensing element design	PZT, shear
Weight	90 grams
Case material	316L stainless steel
Mounting	1/4-28 UNF tapped hole
Mating connector	M12 style, socket
Recommended cabling	J99



Key features

- 300 μ W power consumption
- BOV settling time of <10 ms
- Certified for use in hazardous areas
- Internal temperature sensor
- Manufactured in ISO 9001 facility

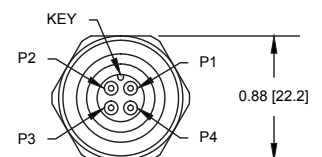
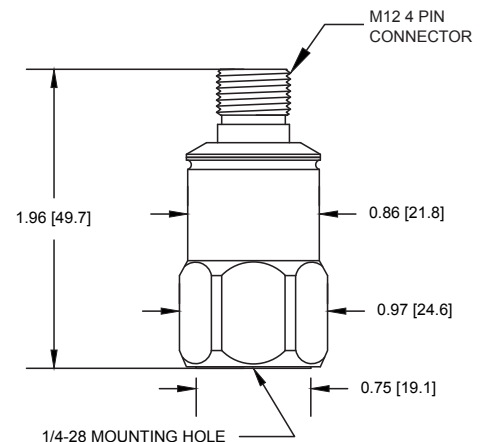

Connections	
Function	Connector pin
power	1
common	2
accel signal	3
temp signal	4
shield*	shell

*For installations requiring CE conformance, cable shield must be tied to sensor case.

Certifications

NOTE: See reverse for installation requirements.



Class I, Div 2 Groups A, B, C, D
Class II, Div 2 Groups E, F, G
Class III; T5
Ex nL IIC T



II 3 G
Ex nA nC IIC T5 Gc
Ex ic IIC T5 Gc
Ta = -50°C to +85°C



Note: Due to continuous process improvement, specifications are subject to change without notice. This document is cleared for public release.

Certified low-power, low-voltage accelerometer

LPA100T-D2



Hazardous area installation requirements

The mating connection shall be made using an M12 connector in compliance with IEC 61076-2-101. This standard requires that the connectors be kept from separating using a lock nut or threaded sleeve on the mating connection. The M12 connector must have a minimum creepage distance of 1.0 mm between adjacent contacts and a minimum distance of 0.2 mm through the solid insulation between adjacent contacts. The M12 connector must use a socket designed to maintain positive compressive force on the connector pin with a minimum diameter of 0.889 mm and maintain a degree of ingress protection of at least IP54 when mated with the integral plug arrangement provided for the Accelerometer.

The equipment does not incorporate an earth bonding facility. It is the responsibility of the user to ensure that earth continuity is maintained, for example, by means of the mounting arrangement.

To limit the supply current to a maximum of 100 μ A, both the acceleration output and the temperature output must be connected to input circuits with a minimum impedance of 150,000 ohms.

The 5.5 Vdc rated supply shall be protected such that transients are limited to a maximum of 90 Vdc.

A degree of ingress protection of at least IP54 shall be maintained even when the cable connector is removed, for example by means of the fitting of a suitable cap.

Conditions for type protection Ex ic IIC T5 Gc installations:

The monitoring equipment must have an input impedance of at least 150,000 ohms for both the accelerometer and the temperature signals.

The cable installed must be suitable for the installation temperature and the voltage of any intermingled circuits.

Where the installation requires that the Accelerometer enclosure be grounded, this is to be done using a metal mounting stud as described in document 78013.

Note: Due to continuous process improvement, specifications are subject to change without notice. This document is cleared for public release.

Данный компонент на территории Российской Федерации

Вы можете приобрести в компании MosChip.

Для оперативного оформления запроса Вам необходимо перейти по данной ссылке:

<http://moschip.ru/get-element>

Вы можете разместить у нас заказ для любого Вашего проекта, будь то серийное производство или разработка единичного прибора.

В нашем ассортименте представлены ведущие мировые производители активных и пассивных электронных компонентов.

Нашей специализацией является поставка электронной компонентной базы двойного назначения, продукции таких производителей как XILINX, Intel (ex.ALTERA), Vicor, Microchip, Texas Instruments, Analog Devices, Mini-Circuits, Amphenol, Glenair.

Сотрудничество с глобальными дистрибьюторами электронных компонентов, предоставляет возможность заказывать и получать с международных складов практически любой перечень компонентов в оптимальные для Вас сроки.

На всех этапах разработки и производства наши партнеры могут получить квалифицированную поддержку опытных инженеров.

Система менеджмента качества компании отвечает требованиям в соответствии с ГОСТ Р ИСО 9001, ГОСТ РВ 0015-002 и ЭС РД 009

Офис по работе с юридическими лицами:

105318, г.Москва, ул.Щербаковская д.3, офис 1107, 1118, ДЦ «Щербаковский»

Телефон: +7 495 668-12-70 (многоканальный)

Факс: +7 495 668-12-70 (доб.304)

E-mail: info@moschip.ru

Skype отдела продаж:

moschip.ru

moschip.ru_4

moschip.ru_6

moschip.ru_9