

From Off-The-Shelf to Market-Ready© New Age Enclosures is your Single Source Solution.
Let us quote modifying our Stock Enclosures to meet your end-use.
visit newageenclosures.com/services or call 855-4NA-ENCL today.

CNC CUTOUTS
PART DECORATING
CUSTOM COLOR AND MATERIAL
RF/EMI SHIELDING
CUSTOM TOOL INSERTS
CUSTOM ENCLOSURES AND DESIGN

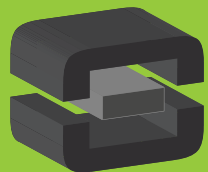

NEW AGE
ENCLOSURES

DEVELOP THE FUTURE



NOTES: UNLESS OTHERWISE SPECIFIED

- CORNERS DRAWN SHARP TO BE R.005 MAXIMUM.
- EXTERIOR SURFACE TEXTURE TO BE LIGHT EDM FINISH. EQUIVALENT TO MT-11020. TEXTURE ON ENCLOSURE WILL VARY FROM TIME TO TIME AS THE TOOL WEARS AND IT BECOMES NECESSARY TO REAPPLY.
- INTERIOR SURFACE TEXTURE TO BE: NONE.
- ALL INSIDE RADII .010R. UNLESS OTHERWISE SPECIFIED.
- ALL EXTERNAL DIMENSIONS AFFECTED BY THE DRAFT APPLY AT THE LARGE END OF THE FEATURE, AND ALL INTERNAL FEATURES AFFECTED BY THE DRAFT APPLY AT THE SMALL END OF THE FEATURE UNLESS OTHERWISE SPECIFIED.
- 1 DEGREE DRAFT IN THE DIRECTION OF PULL IS PERMISSIBLE UNLESS OTHERWISE SPECIFIED.
- MATERIAL / COLOR: ASA PLASTIC IS STANDARD IN BLACK OR GRAY. CUSTOM MATERIALS AND COLORS ARE AVAILABLE UPON REQUEST FOR QUOTE. ALTERNATE RESINS HAVE DIFFERENT SHRINK RATES, AND WILL EFFECT DIMENSIONS.
- PCB SIZES ARE RECOMMENDATIONS ONLY. FINAL SIZES AND VERIFICATION OF ITS FIT ARE THE SOLE RESPONSIBILITY OF EACH CUSTOMER.
- ASSEMBLY SCREWS FOR THE ENCLOSURE INCLUDED. MOUNTING SCREWS FOR THE PCB AND WALL ARE SOLD SEPARATELY.
- THIS DRAWING IS BASED ON A SOLID MODEL, AND IS FURTHER DEFINED BY THE SOLID MODEL FILE.
- ALLOWABLE FLASH: 0.010 MAX.
- ALL EJECTOR PIN MARKS TO BE WITHIN 0.010" OF FLUSH, PROTRUDING OR BELOW FLUSH.
- TRIM GATE WITHIN 0.030" OF FLUSH.
- THIS ENCLOSURE IS DESIGNED FOR OUTDOOR USE AND MEETS IPX7 INGRESS PROTECTION STANDARD.

R E V I S I O N					
REV.	DRAWN BY	ECO No	DESCRIPTION	DATE	APPROVE
A	M BOYER		PRELIMINARY RELEASE	2017-Jun-07	D.C.
B	M BOYER		REMOVE SCREW HOLES ENLARGE STRAP SLOT	2017-Jun-13	D.C.
C	M BOYER		REVISE SLOT WITH SINGLE SCREW HOLE ADDED	2017-Jun-15	D.C.
D	M BOYER		REVISE NOTES	2017-Jun-16	D.C.
E	M BOYER		THICKEN WALL TABS	2017-Jun-22	D.C.
F	M BOYER		INCREASE LENGTH BY .03 TO FIT OTS ORING	2018-Feb-16	D.C.
G	M BOYER		INCREASE COVER HEIGHT	2018-Feb-21	D.C.
I	M BOYER		ADD EAR GUSSETS	2018-Mar-16	D.C.
J	M BOYER		INCLUDE CONFIG TREE	2018-Jun-18	D.C.
K	R CRUZ		UPDATE O-RING DETAILS	2018-Aug-22	D.C.
1.0	R CRUZ	00319	UPDATE TO AS BUILT AND RELEASE TO MFG	2019-Feb-19	



SCALE 1.000

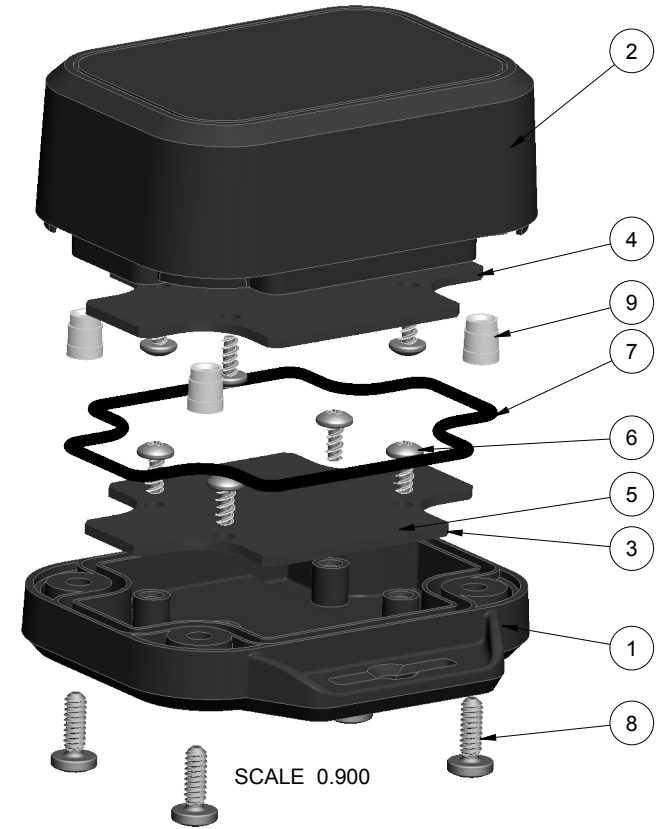

SCALE 0.900

SXX-272013(x) CONFIGURATIONS		
	-blank	-B1
272013 COVER w/ STANDARD TEXTURE	1	
272013 COVER w/ POLISHED LABEL RECESS		1
272013 WALL BASE	1	1
272013 ORING	1	1
6-32 x .375" STAINLESS PHILLIPS SCREW	4	4

9	PEM-INSERT_6-32	PEM INSERT 6-32 x .250"	BRASS	OVER MOLDED	4
8	6-32_PHILLIPS_SCREW	6-32 PHILLIPS SCREW x .375"	STAINLESS STEEL	MMC 91772A146	4
7	272013-ORING	272013 ORING, OR-036	SHORE A	INCLUDED	1
6	SCREW_HILO-N04X250	#4 HiLo SCREW x .250"	ZINC PLATED	CUSTOMER SUPPLIED	8
5	SCREW-DRYWALLX750	DRYWALL SCREW	REFERENCE ONLY	CUSTOMER SUPPLIED	2
4	272013-PCB-TOP	272013 TOP PCB - REFERENCE	.062" THICK	CUSTOMER SUPPLIED	1
3	272013-PCB-BOT	272013 BOTTOM PCB - REFERENCE	.062" THICK	CUSTOMER SUPPLIED	1
2	272013-COVER	272013 COVER - STANDARD	ASA	BLACK or GRAY	1
1	272013-BASE	272013 BASE - STANDARD	ASA	BLACK or GRAY	1
ITEM	FILE NAME	DESCRIPTION	MATERIAL	COLOR	QTY.

BILL OF MATERIALS

THIRD ANGLE PROJECTION
DO NOT SCALE DRAWING

TOLERANCES: UNLESS OTHERWISE SPECIFIED DIMENSIONS ARE IN U.S. INCHES.
X.XX = .015 X.XXXX = .001
X.XXX = .010 X.X" = 1°

NEW AGE ENCLOSURES

Customer's Part No: 272013

APPROVAL	BY	DATE
CHECK		
ENG.		
SCALE	AS NOTED	

DRAWN BY
M BOYER

2017-Jun-07

NEW AGE ENCLOSURES
2240 South Thornburg Street Santa Maria, CA. 93455
ph. (805) 595-1310 fax (805) 595-1024
www.newageenclosures.com

SM OUTDOOR UTILITY - STANDARD
SXX-272013-XXX

SIZE	DRAWING NAME	SHEET	REV.DOC
A	272013_R1_0	1 OF 6	1.0

272013 ASSEMBLY

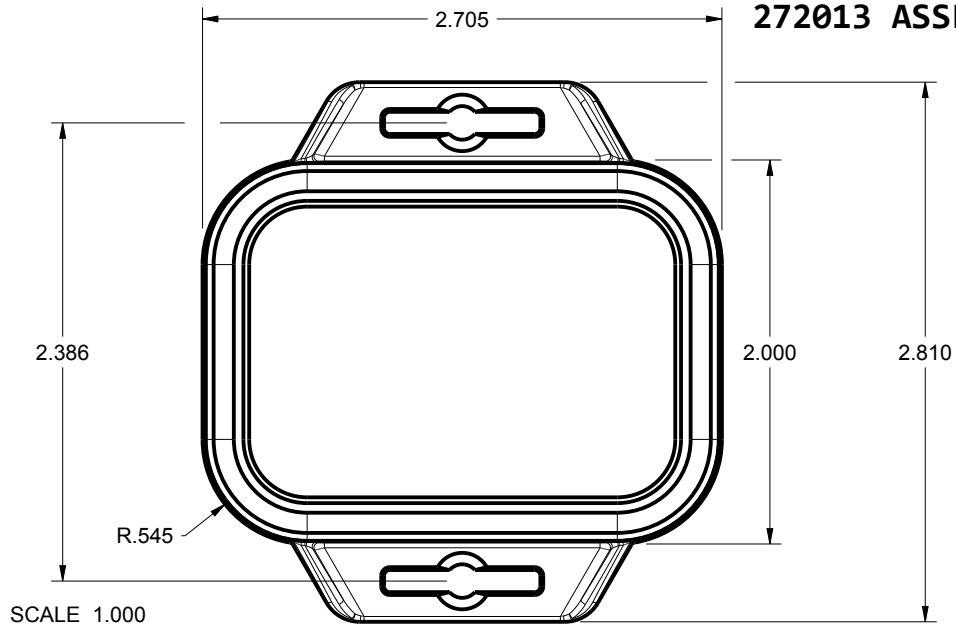

SCALE 1.000

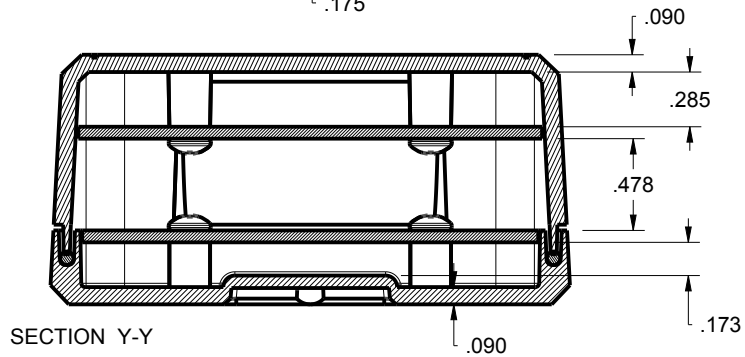
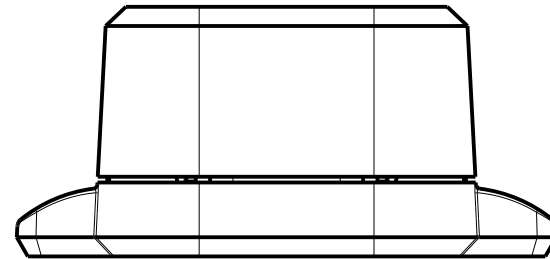
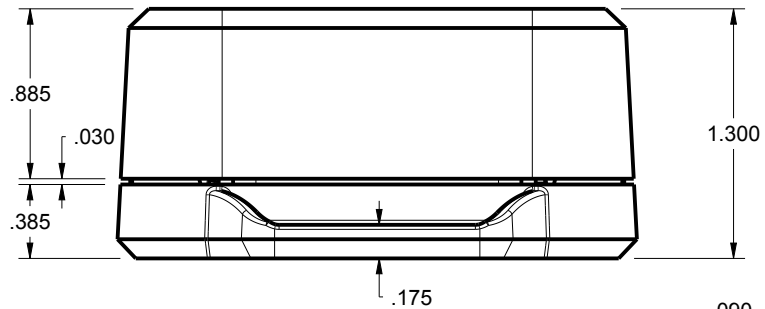

TOLERANCES: UNLESS OTHERWISE SPECIFIED
DIMENSIONS ARE IN U.S. INCHES.
X.XX = .015 X.XXXX = .001
X.XXX = .010 X.X° = 1°

NEW AGE ENCLOSURES
Customer's Part No: 272013

APPROVAL	BY	DATE
CHECK		
ENG.		
SCALE	AS NOTED	

DRAWN BY	2017-Jun-07
M BOYER	

NEW AGE ENCLOSURES
2240 South Thornburg Street Santa Maria, CA. 93455
ph. (805) 595-1310 fax (805) 595-1024
www.newageenclosures.com

SM OUTDOOR UTILITY - STANDARD
SXX-272013-XXX

SIZE	DRAWING NAME
A	272013_R1_0

SHEET	REV.DOC
2 OF 6	1.0

272013 COVER

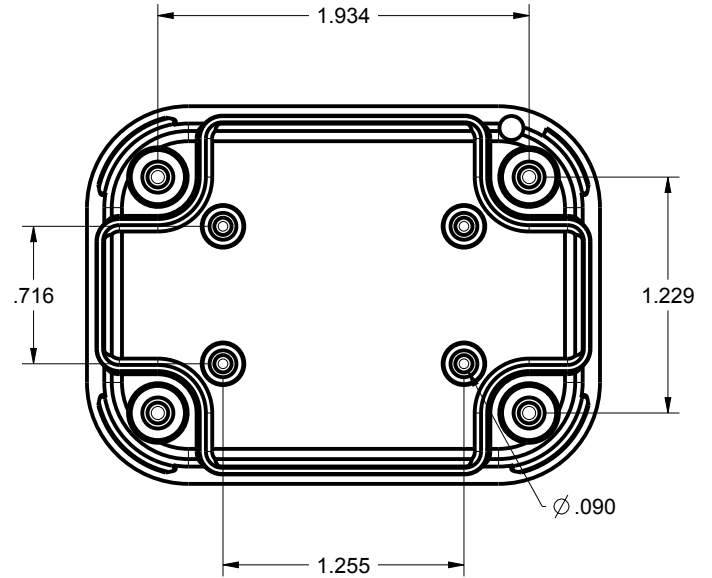
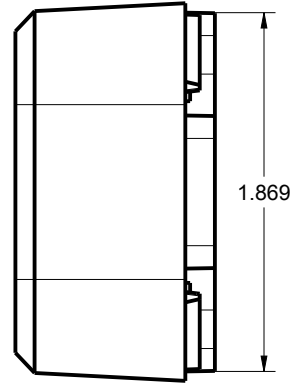
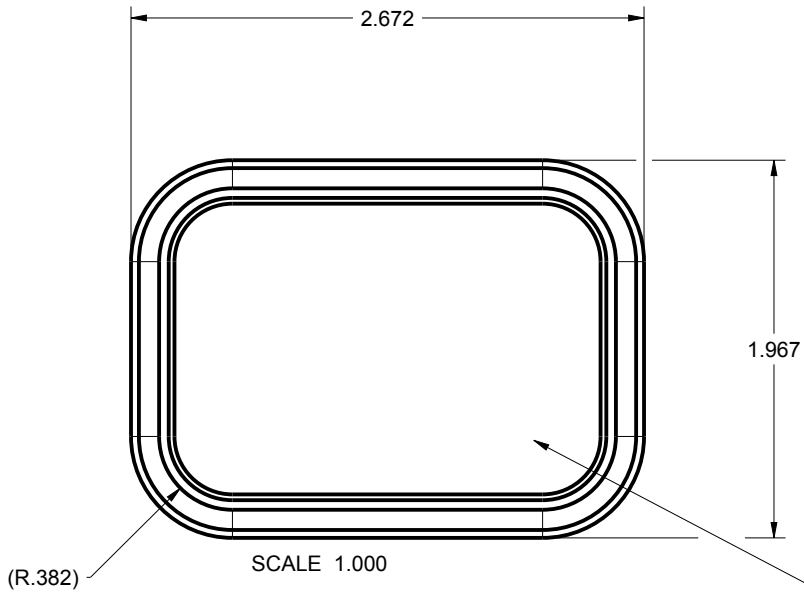

CONFIG 272013B1 = LABEL
RECESS POLISHED TO B1 FINISH

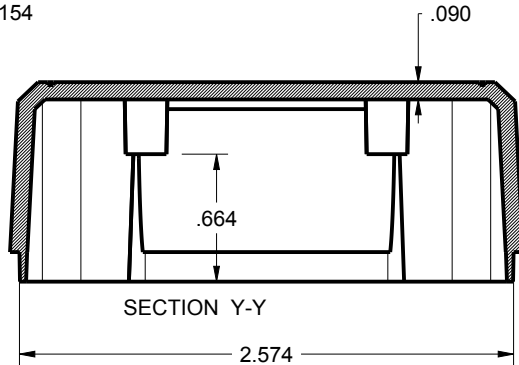
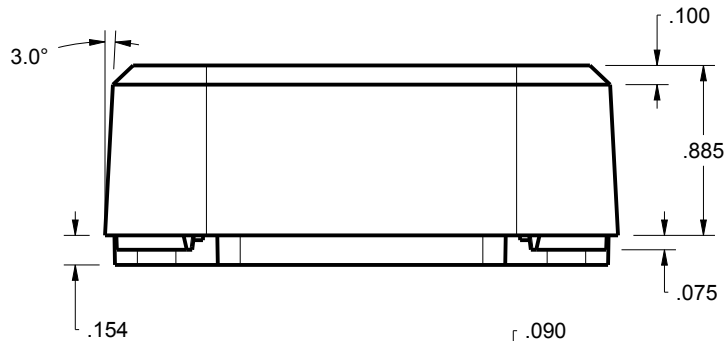

TOLERANCES: UNLESS OTHERWISE SPECIFIED
DIMENSIONS ARE IN U.S. INCHES.
X.XX = .015 X.XXXX = .001
X.XXX = .010 X.X° = 1°

NEW AGE ENCLOSURES
Customer's Part No: 272013

APPROVAL	BY	DATE
CHECK		
ENG.		
SCALE	AS NOTED	

DRAWN BY
M BOYER 2017-Jun-07

NEW AGE ENCLOSURES
2240 South Thornburg Street Santa Maria, CA. 93455
ph. (805) 595-1310 fax (805) 595-1024
www.newageenclosures.com

SM OUTDOOR UTILITY - STANDARD
SXX-272013-XXX

SIZE A	DRAWING NAME 272013_R1_0	SHEET 3 OF 6	REV.DOC 1.0
-----------	-----------------------------	-----------------	----------------

272013 WALL BASE

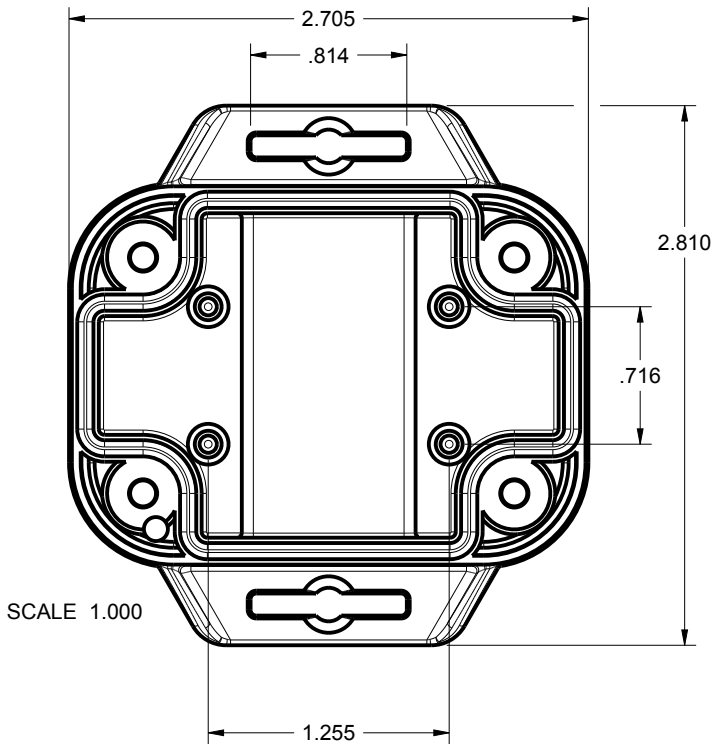

SCALE 1.000

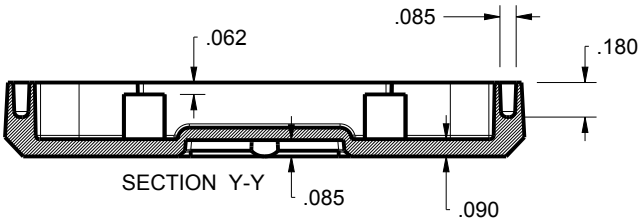
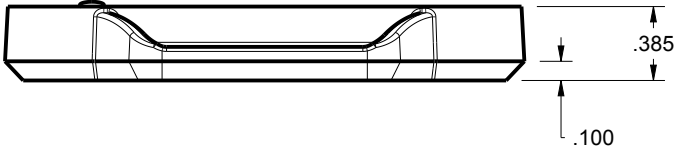
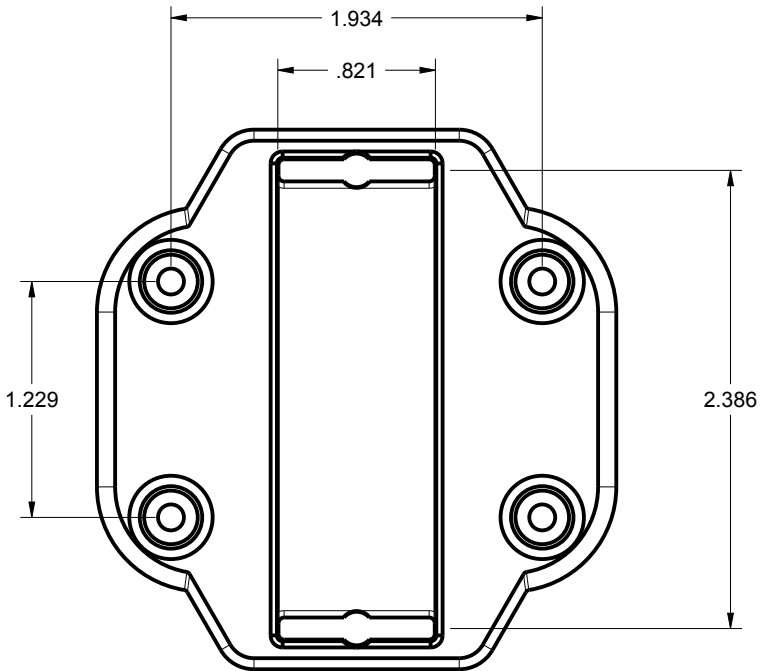

TOLERANCES: UNLESS OTHERWISE SPECIFIED DIMENSIONS ARE IN U.S. INCHES.
 X.XX = .015 X.XXXX = .001
 X.XXX = .010 X.X° = 1°

NEW AGE ENCLOSURES
 Customer's Part No: 272013

APPROVAL	BY	DATE
CHECK		
ENG.		
SCALE	AS NOTED	
DRAWN BY	2017-Jun-07	
M BOYER		

NEW AGE ENCLOSURES
 2240 South Thornburg Street Santa Maria, CA. 93455
 ph. (805) 595-1310 fax (805) 595-1024
www.newageenclosures.com

SM OUTDOOR UTILITY - STANDARD
 SXX-272013-XXX

SIZE	DRAWING NAME	SHEET	REV.DOC
A	272013_R1_0	4 OF 6	1.0

272013 PCB - CUSTOMER SUPPLIED

PCB SIZES ARE RECOMMENDATIONS ONLY. FINAL SIZES AND VERIFICATION OF ITS FIT ARE THE SOLE RESPONSIBILITY OF THE OEM.

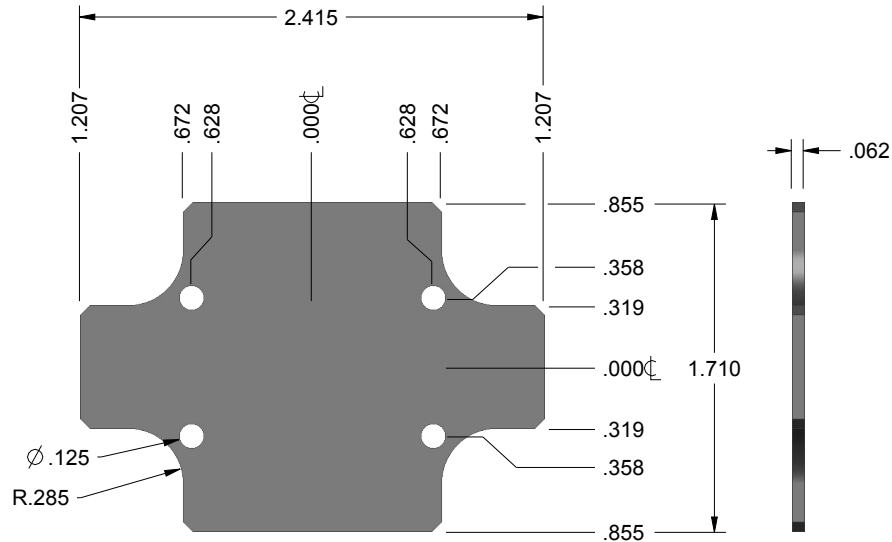

272013 TOP PCB
SCALE 1.000

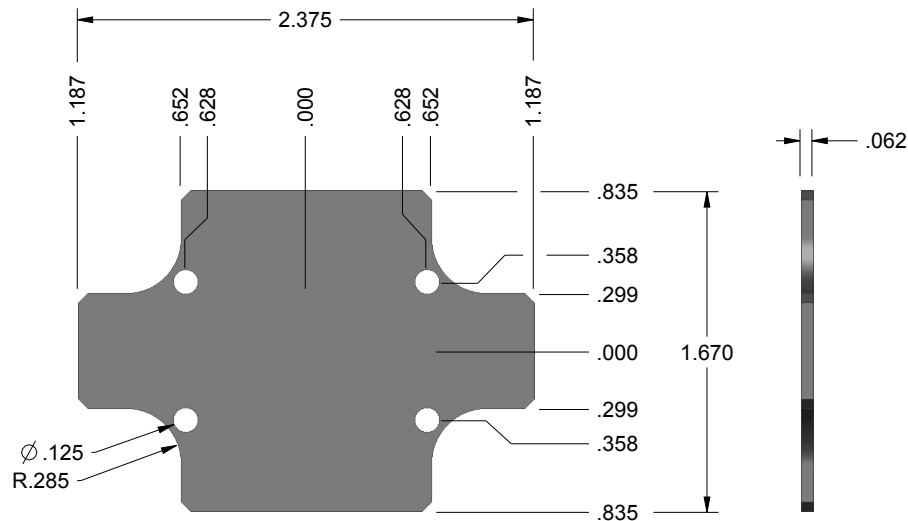

272013 BOTTOM PCB
SCALE 1.000

272013 O-RING

OR-036 DUROMETER 70A (MEDIUM) OR EQUIVALENT

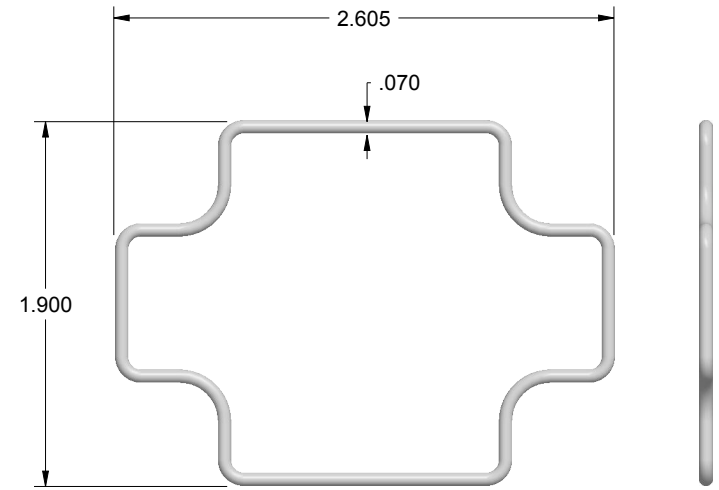

SCALE 1.000

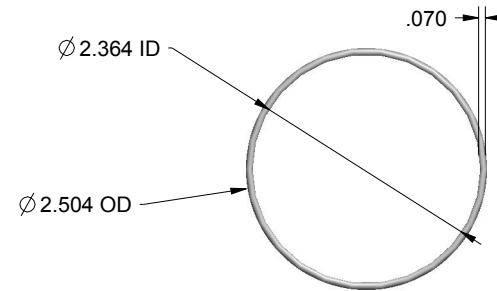

OFF THE SHELF EQUIVALENT
SCALE 0.500

TOLERANCES: UNLESS OTHERWISE SPECIFIED DIMENSIONS ARE IN U.S. INCHES.
X.XX = .015 X.XXXX = .001
X.XXX = .010 X.X° = 1°

NEW AGE ENCLOSURES
Customer's Part No: 272013

APPROVAL	BY	DATE
CHECK		
ENG.		
SCALE	AS NOTED	

DRAWN BY
M BOYER 2017-Jun-07

NEW AGE ENCLOSURES
2240 South Thornburg Street Santa Maria, CA. 93455
ph. (805) 595-1310 fax (805) 595-1024
www.newageenclosures.com

SM OUTDOOR UTILITY - STANDARD
SXX-272013-XXX

SIZE A	DRAWING NAME 272013_R1_0	SHEET 5 OF 6	REV.DOC 1.0
-----------	-----------------------------	-----------------	----------------

272013 - 2nd OPERATION DETAILS

NEW AGE ENCLOSURES DELIVERS YOUR ENCLOSURE MARKET-READY WITH IN-HOUSE
CNC MACHINING, PAD PRINTING, ASSEMBLY, AND FULFILLMENT.
ALL SURFACES AND AREAS ARE AVAILABLE FOR CNC ALTERATION BY NEW AGE ENCLOSURES
CALL (805) 595-1310 FOR PRICING AND SCHEDULE.
THE INSIDE RADIUS OF ANY MACHINED FEATURES SHOULD BE NO SMALLER THAN .031"

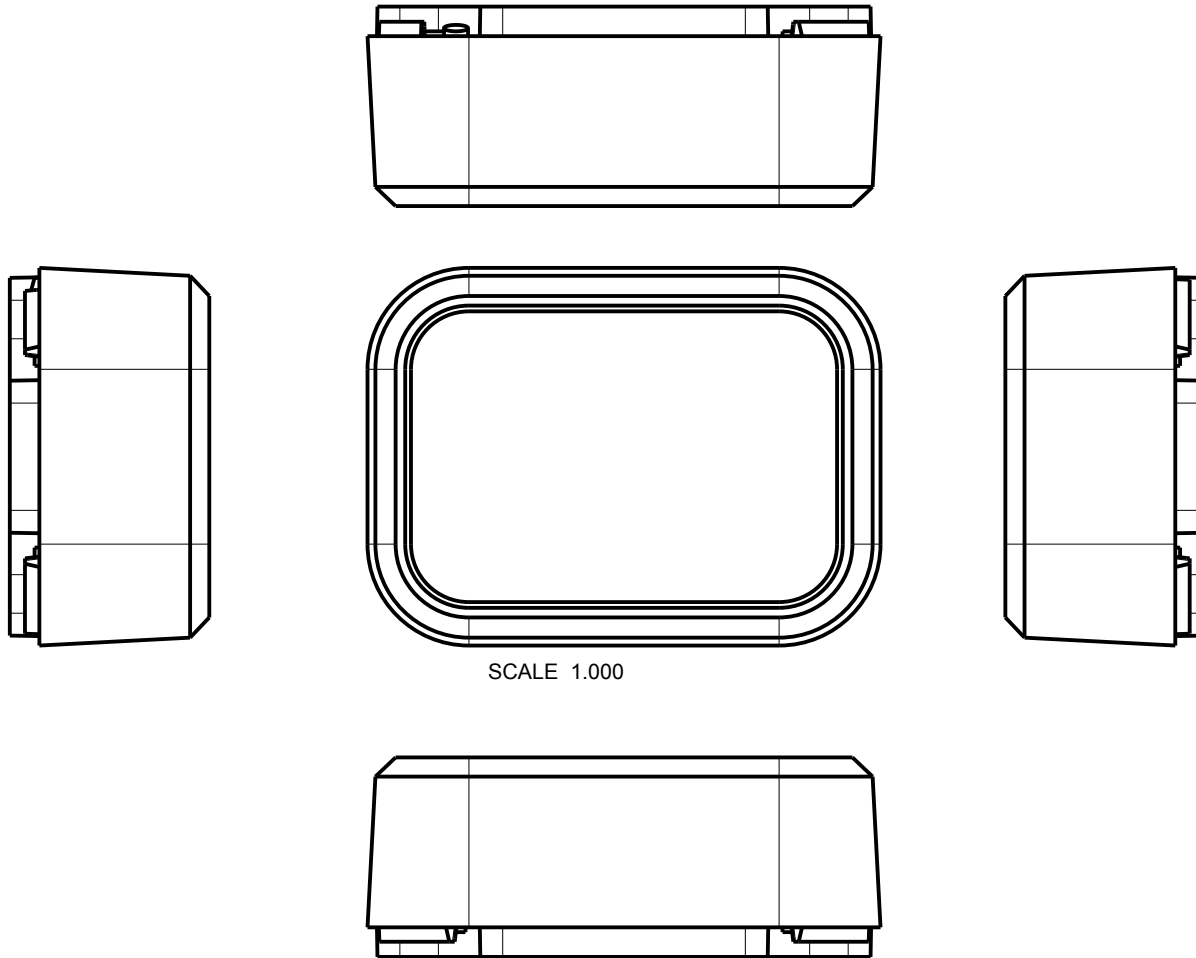

SCALE 1.000

TOLERANCES: UNLESS OTHERWISE SPECIFIED
DIMENSIONS ARE IN U.S. INCHES.
X.XX = .015 X.XXXX = .001
X.XXX = .010 X.X° = 1°

NEW AGE ENCLOSURES

Customer's Part No: 272013

NEW AGE ENCLOSURES
2240 South Thornburg Street Santa Maria, CA. 93455
ph. (805) 595-1310 fax (805) 595-1024

www.newageenclosures.com

APPROVAL	BY	DATE
CHECK		
ENG.		
SCALE	AS NOTED	
DRAWN BY		
M BOYER	2017-Jun-07	

**SM OUTDOOR UTILITY - STANDARD
SXX-272013-XXX**

SIZE	DRAWING NAME	SHEET	REV.DOC
A	272013_R1_0	6 OF 6	1.0

SXX-272013-XXX COVER - ASA, BLACK

STEP	DESCRIPTION	CUTTER	FIXTURE	ORIENTATION	PROGRAM
1-C-C1	-	T2 = .062" EM	TBD	-	o1001
2-C-C2	-	T2 = .062" EM	TBD	-	o1002

Mouser Electronics

Authorized Distributor

Click to View Pricing, Inventory, Delivery & Lifecycle Information:

[New Age Enclosures:](#)

[S3L-272013](#)

Данный компонент на территории Российской Федерации

Вы можете приобрести в компании MosChip.

Для оперативного оформления запроса Вам необходимо перейти по данной ссылке:

<http://moschip.ru/get-element>

Вы можете разместить у нас заказ для любого Вашего проекта, будь то серийное производство или разработка единичного прибора.

В нашем ассортименте представлены ведущие мировые производители активных и пассивных электронных компонентов.

Нашей специализацией является поставка электронной компонентной базы двойного назначения, продукции таких производителей как XILINX, Intel (ex.ALTERA), Vicor, Microchip, Texas Instruments, Analog Devices, Mini-Circuits, Amphenol, Glenair.

Сотрудничество с глобальными дистрибьюторами электронных компонентов, предоставляет возможность заказывать и получать с международных складов практически любой перечень компонентов в оптимальные для Вас сроки.

На всех этапах разработки и производства наши партнеры могут получить квалифицированную поддержку опытных инженеров.

Система менеджмента качества компании отвечает требованиям в соответствии с ГОСТ Р ИСО 9001, ГОСТ РВ 0015-002 и ЭС РД 009

Офис по работе с юридическими лицами:

105318, г.Москва, ул.Щербаковская д.3, офис 1107, 1118, ДЦ «Щербаковский»

Телефон: +7 495 668-12-70 (многоканальный)

Факс: +7 495 668-12-70 (доб.304)

E-mail: info@moschip.ru

Skype отдела продаж:

moschip.ru

moschip.ru_4

moschip.ru_6

moschip.ru_9