

## 19 GHz VCO with Prescaler

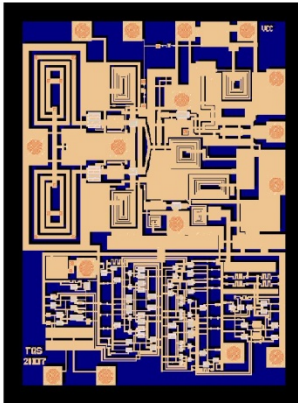

### Measured Performance

Bias conditions:  $V_{cc} = 5\text{ V}$ ,  $I_{total} = 165\text{ mA}$

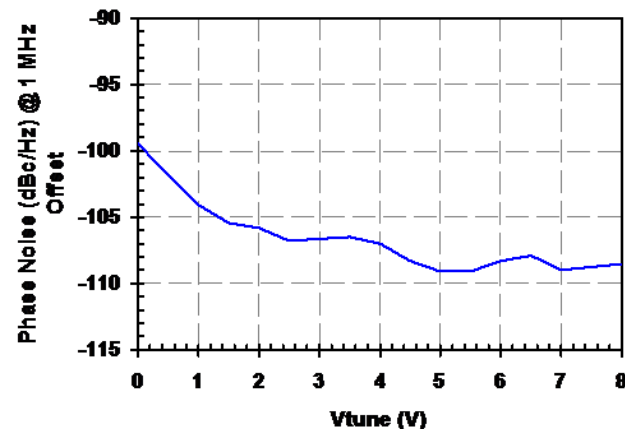
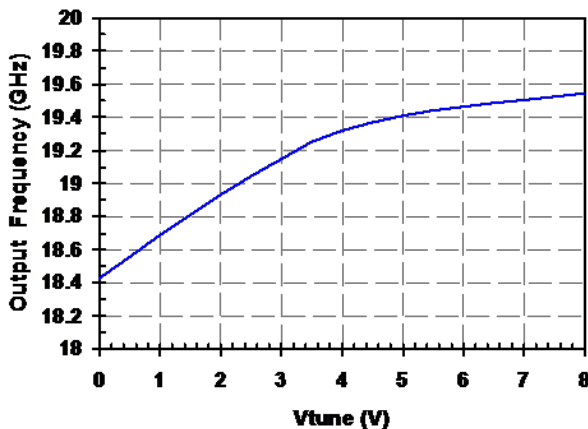

### Key Features

- Frequency Range: 18.5 – 19.5 GHz
- Output Power: 7 dBm @ 19 GHz
- Phase Noise: -105 dBc/Hz at 1 MHz offset,  $f_c=19\text{ GHz}$
- Prescaler Output Freq Range : 2.31 – 2.44 GHz
- Prescaler Output Power: -6 dBm
- Bias:  $V_{cc} = 5\text{ V}$ ,  $I_{total} = 165\text{ mA}$  Typical
- Technology: HBT3
- Chip Dimensions: 1.28 x 1.71 x 0.38 mm

### Primary Applications

- Automotive Radar

### Product Description

The TriQuint TGV2204-FC is a flip-chip voltage controlled oscillator (VCO) designed to operate at frequencies that target the automotive Radar market. The TGV2204-FC is designed using TriQuint's proven HBT3 process and front-side Cu / Sn pillar technology for simplified assembly and low interconnect inductance.

The TGV2204-FC is a VCO that typically provides 7 dBm output power at 19 GHz with < -105 dBc/Hz phase noise at 1 MHz offset . The integrated divide-by-8 prescaler eases PLL design. The TGV2204-FC is an excellent choice for applications requiring frequency stability in transmit chain architectures.

The TGV2204-FC has a protective surface passivation layer providing environmental robustness.

Lead-free and RoHS compliant.

**Table I**  
**Absolute Maximum Ratings 1/**

<b>Symbol</b>	<b>Parameter</b>	<b>Value</b>	<b>Notes</b>
Vcc	Collector Voltage	11 V	2/
Vtune	Tune Voltage	11 V	
Itotal	Collector Current	276 mA	2/

- 1/ These ratings represent the maximum operable values for this device. Stresses beyond those listed under "Absolute Maximum Ratings" may cause permanent damage to the device and / or affect device lifetime. These are stress ratings only, and functional operation of the device at these conditions is not implied.
- 2/ Combinations of supply voltage, supply current shall not exceed the maximum power dissipation listed in Table IV.

**Table II**  
**Recommended Operating Conditions**

<b>Symbol</b>	<b>Parameter 1/</b>	<b>Value</b>
Vcc	Collector Voltage	5 V $\pm$ 5%
Itotal	Collector Current	165 mA
Vtune	VCO Freq Tune Voltage	0-8 V

- 1/ See assembly diagram for bias instructions.

**Table III**  
**RF Characterization Table**

**Bias: Vcc = 5 V, Itotal = 165 mA, typical**

SYMBOL	PARAMETER	TEST CONDITIONS	MINIMUM	NOMINAL	MAXIMUM	UNITS
RF Out	Output Power	f = 19 – 19.25 GHz	5	7	13	dBm
PN	Phase Noise @ 1 MHz Offset	f = 19 – 19.25 GHz		-107		dBc/Hz
F/8 Pout 1/	Prescaler Output Power 1/	f = 19 – 19.25 GHz	-11	-6	2	dBm
F/8 Freq	Prescaler Output Frequency	f = 19 – 19.25 GHz		2.31 – 2.44		GHz
Fout 2V	Output Frequency, Vtune = 2 V		18.6	18.95	19.2	GHz
Fout 8V	Output Frequency, Vtune = 8 V		19.4	19.56	20.0	GHz

1/ Single-ended output power measurement

**Table IV**  
**Power Dissipation and Thermal Properties**

Parameter	Test Conditions	Value	Notes
Maximum Power Dissipation	Tbaseplate = 70 °C	Pd = TBD W Tjunction = TBD °C Tm = TBD Hrs	1/ 2/
Thermal Resistance, $\theta_{jc}$	Vcc = 5 V Id = 165 mA Pd = 0.825 W Tbaseplate = 70 °C	$\theta_{jc}$ = 80.4 (°C/W) Tjunction = 133.5 °C Tm = TBD Hrs	
Mounting Temperature		Refer to Solder Reflow Profiles (pp 11)	
Storage Temperature		-65 to 150 °C	

- 1/ For a median life of 1E+6 hours, Power Dissipation is limited to  

$$Pd(max) = (150\text{ °C} - Tbase\text{ °C})/\theta_{jc}.$$
- 2/ Junction operating temperature will directly affect the device median time to failure (MTTF). For maximum life, it is recommended that junction temperatures be maintained at the lowest possible levels.

**Median Lifetime (Tm) vs Channel Temperature**

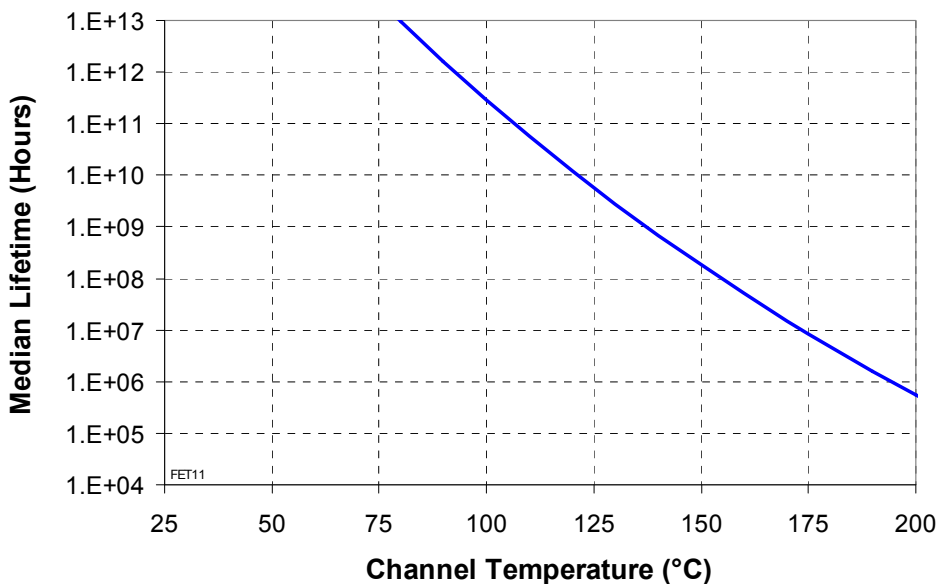

**Measured Data on Face-down (flipped) Die on Carrier Board**

Bias conditions:  $V_{cc} = 5\text{ V}$ ,  $I_{total} = 165\text{ mA}$

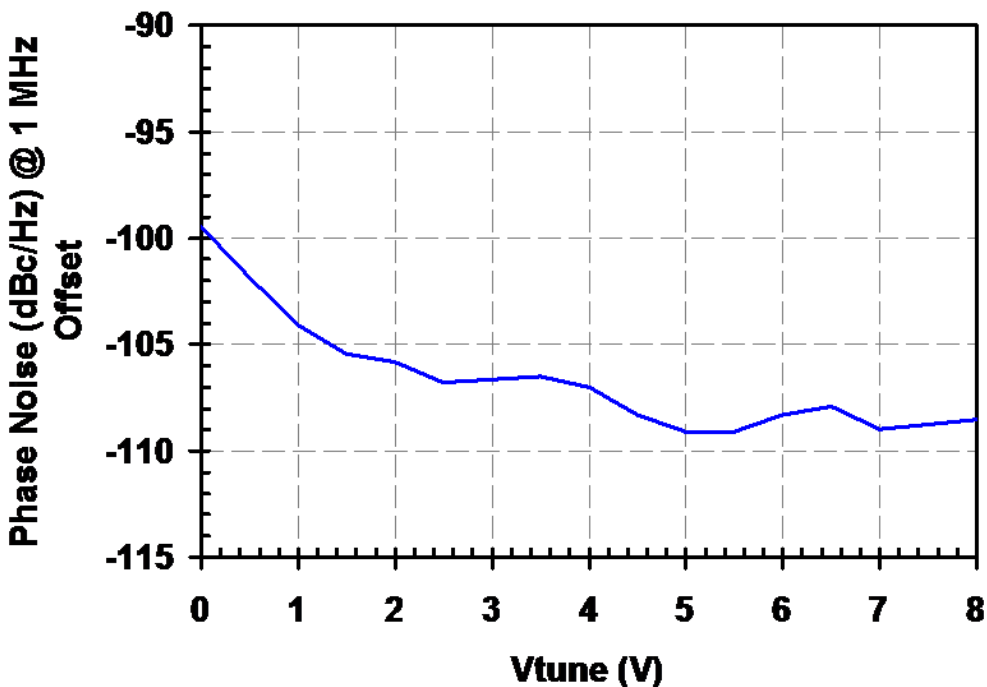
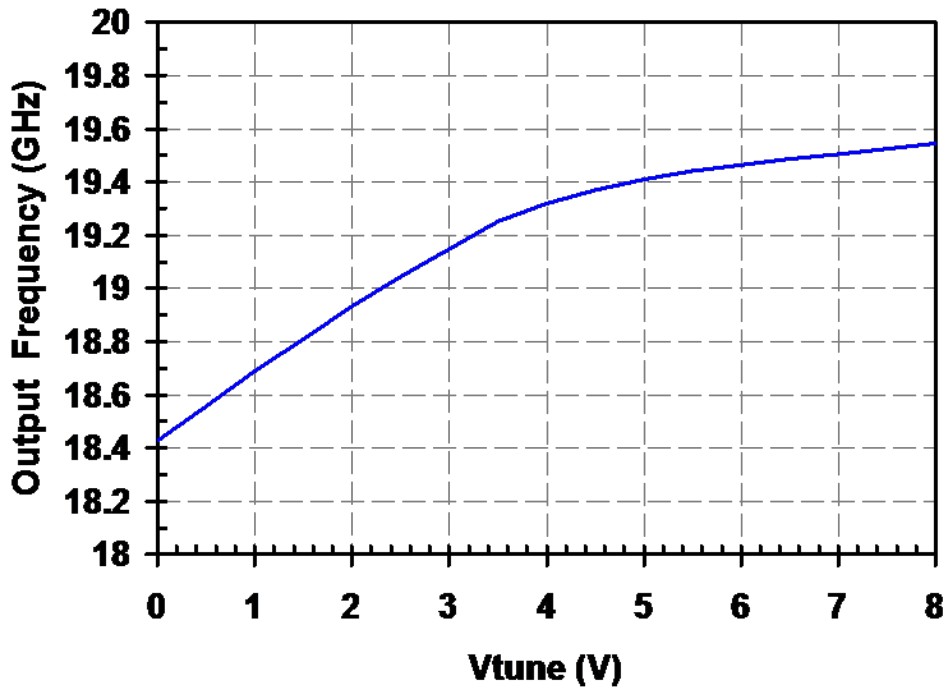

**Measured Data on Face-down (flipped) Die on Carrier Board**

Bias conditions:  $V_{cc} = 5\text{ V}$ ,  $I_{total} = 165\text{ mA}$

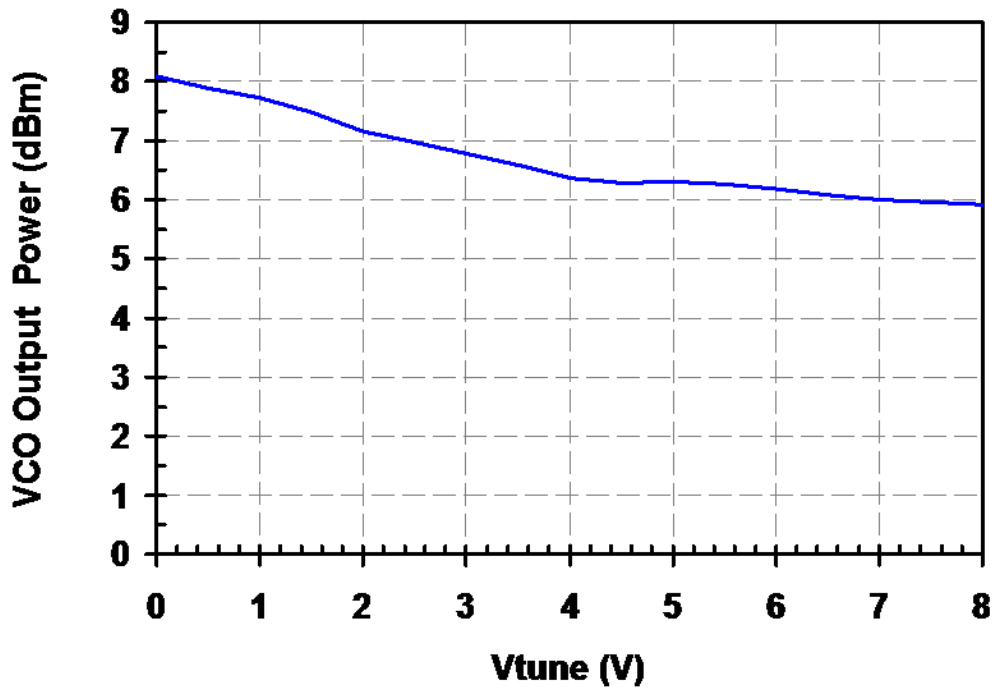

**Electrical Schematic**

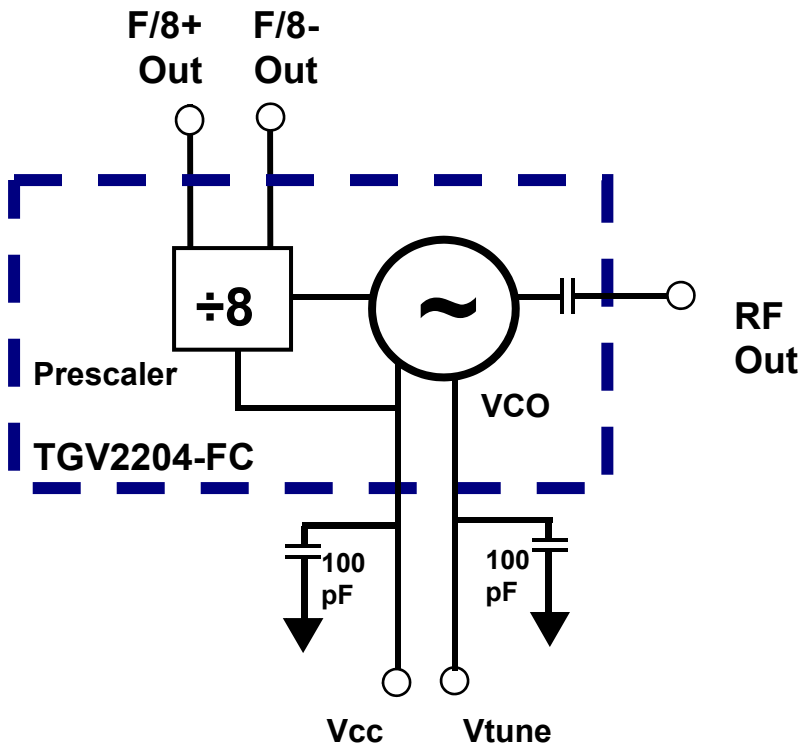

**Bias Procedures**

**Bias-up Procedure**

Vtune set to ~ +2 V (for desired Freq)

Vcc set to 5 V ± 5%

For single-ended use of the prescaler (F/8+), the F/8- output pin may be left open

**Bias-down Procedure**

Reduce Vcc to 0 V.

Turn Vtune to 0 V

## Mechanical Drawing

Drawing is for chip face-up

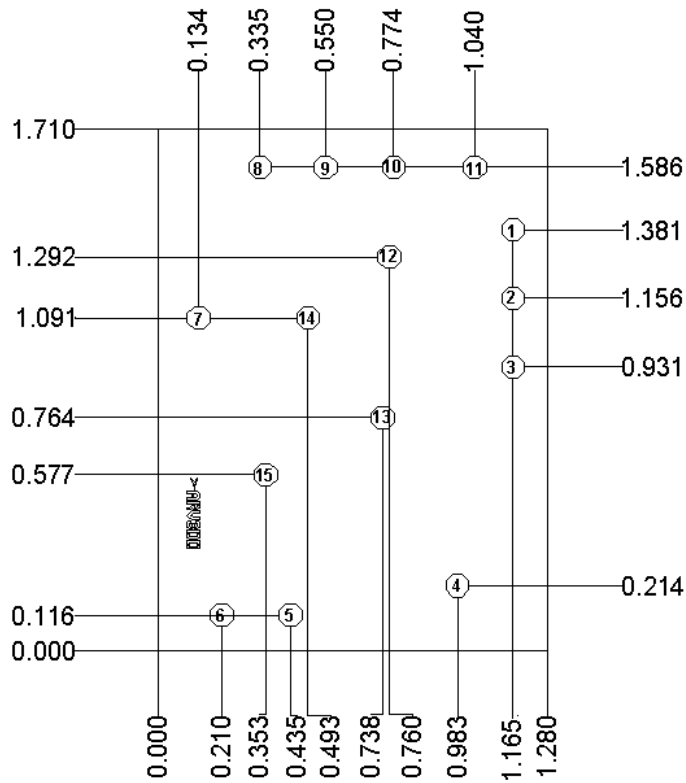

Units: millimeters

Thickness: 0.38

Die x,y size tolerance: +/- 0.050

Chip edge to pillar dimensions are shown to center of pillar

Pillar #4, 7, 10, 12-15	DC Ground	0.075 $\phi$	Pillar #6	Prescaler Out (F/8+)	0.075 $\phi$
Pillar #1, 3	RF CPW Ground	0.075 $\phi$	Pillar #8	Vtune	0.075 $\phi$
Pillar #2	RF Out	0.075 $\phi$	Pillar #9	Vbb (Not Used)	0.075 $\phi$
Pillar #5	Prescaler Out (F/8-)	0.075 $\phi$	Pillar #11	Vcc	0.075 $\phi$

**GaAs MMIC devices are susceptible to damage from Electrostatic Discharge. Proper precautions should be observed during handling, assembly and test.**



**Recommended Assembly Diagram**

Alumina substrate board  
Thickness: 0.38 mm  
 $\epsilon_r = 9.9$

Prescaler F/8- Output  
Prescaler F/8+ Output

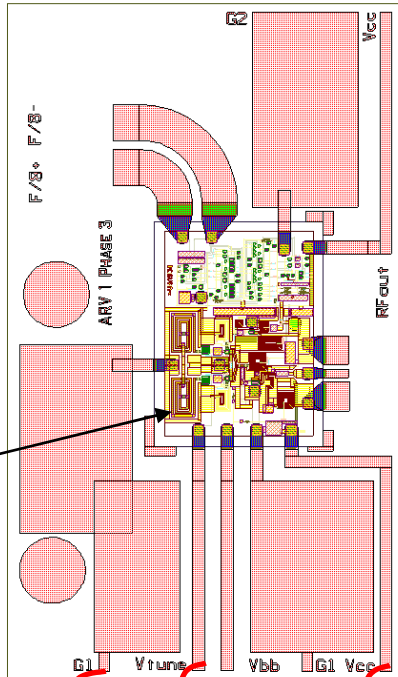

TGV2204-FC Die  
(flip-chip bonded)

RF Gnd  
RFout  
RF Gnd

TGV2204-FC data represented in this datasheet was taken using coplanar waveguide (CPW) transition on the substrate and ground-signal-ground probes

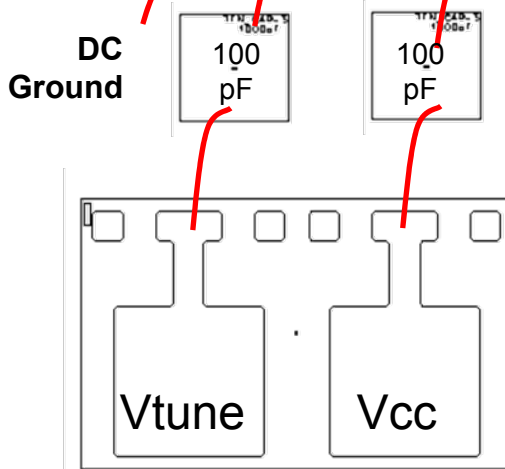

Die is flip-chip bonded / bumped to carrier

**NOTE:** Vcc should be bypassed sufficiently to avoid phase noise degradation. Bypass capacitors of 1 uF and 470 uF are recommended. Tuning port should also be free of supply noise.

*GaAs MMIC devices are susceptible to damage from Electrostatic Discharge. Proper precautions should be observed during handling, assembly and test.*

## Assembly Notes

Component placement and die attach assembly notes:

- Vacuum pencils and/or vacuum collets are the preferred method of pick up.
- Air bridges must be avoided during placement.
- Cu pillars on die are 65 um tall with a 22 um tall Sn solder cap.
- Recommended board metallization is evaporated TiW followed by nickel/gold at pillar attach interface. Ni is the adhesion layer for the solder and the gold keeps the Ni from oxidizing. The Au should be kept to a minimum to avoid embrittlement; suggested Au / Sn mass ratio must not exceed 8%.
- Au metallization is not recommended on traces due to solder wicking and consumption concerns. If Au traces are used, a physical solder barrier must be applied or designed into the pad area of the board. The barrier must be sufficient to keep the solder from undercutting the barrier.

Reflow process assembly notes:

- Minimum alloying temperatures 245 C.
- Repeating reflow cycles is not recommended due to Sn consumption on the first reflow cycle.
- An alloy station or conveyor furnace with an inert atmosphere such as N2 should be used.
- Dip copper pillars in “no-clean flip chip” flux prior to solder attach. Suggest using a high temperature flux. Avoid exposing entire die to flux.
- If screen printing flux, use small apertures and minimize volume of flux applied.
- Coefficient of thermal expansion matching between the MMIC and the substrate/board is critical for long-term reliability.
- Devices must be stored in a dry nitrogen atmosphere.
- Suggested reflow will depend on board material and density.

See Triquint Application Note for flip-chip soldering process: TBD

## Typical Reflow Profiles for TriQuint Cu / Sn Pillars

Process	Sn Reflow
Ramp-up Rate	3 °C/sec
Flux Activation Time and Temperature	60 – 120 sec @ 140 – 160 °C
Time above Melting Point (245 C)	60 – 150 sec
Max Peak Temperature	300 °C
Time within 5 □C of Peak Temperature	10 – 20 sec
Ramp-down Rate	4 – 6 °C/sec

## Ordering Information

Part	Package Style
TGV2204-FC	GaAs MMIC Die

***GaAs MMIC devices are susceptible to damage from Electrostatic Discharge. Proper precautions should be observed during handling, assembly and test.***

## Данный компонент на территории Российской Федерации

### Вы можете приобрести в компании MosChip.

Для оперативного оформления запроса Вам необходимо перейти по данной ссылке:

<http://moschip.ru/get-element>

Вы можете разместить у нас заказ для любого Вашего проекта, будь то серийное производство или разработка единичного прибора.

В нашем ассортименте представлены ведущие мировые производители активных и пассивных электронных компонентов.

Нашей специализацией является поставка электронной компонентной базы двойного назначения, продукции таких производителей как XILINX, Intel (ex.ALTERA), Vicor, Microchip, Texas Instruments, Analog Devices, Mini-Circuits, Amphenol, Glenair.

Сотрудничество с глобальными дистрибьюторами электронных компонентов, предоставляет возможность заказывать и получать с международных складов практически любой перечень компонентов в оптимальные для Вас сроки.

На всех этапах разработки и производства наши партнеры могут получить квалифицированную поддержку опытных инженеров.

Система менеджмента качества компании отвечает требованиям в соответствии с ГОСТ Р ИСО 9001, ГОСТ РВ 0015-002 и ЭС РД 009

### Офис по работе с юридическими лицами:

105318, г.Москва, ул.Щербаковская д.3, офис 1107, 1118, ДЦ «Щербаковский»

Телефон: +7 495 668-12-70 (многоканальный)

Факс: +7 495 668-12-70 (доб.304)

E-mail: [info@moschip.ru](mailto:info@moschip.ru)

Skype отдела продаж:

moschip.ru

moschip.ru\_4

moschip.ru\_6

moschip.ru\_9