

**NOTE**

All numerical values are in metric units [with U.S. customary units in brackets]. Dimensions are in millimeters. Unless otherwise specified, dimensions have a tolerance of ± 0.13 mm and angles have a tolerance of $\pm 2^\circ$. Figures and illustrations are for identification only and are not drawn to scale.

1. INTRODUCTION

This specification covers the requirements for application of NECTOR S Bus Bar Connectors. These connectors provide a branch circuit tap into two conductor cord type power cables. This bus bar connector accepts a NECTOR S plug to distribute power to lamps or other accessories.

When corresponding with TE Connectivity Personnel, use the terminology provided in this specification to facilitate inquiries for information. Basic terms and features of this product are provided in Figure 1.

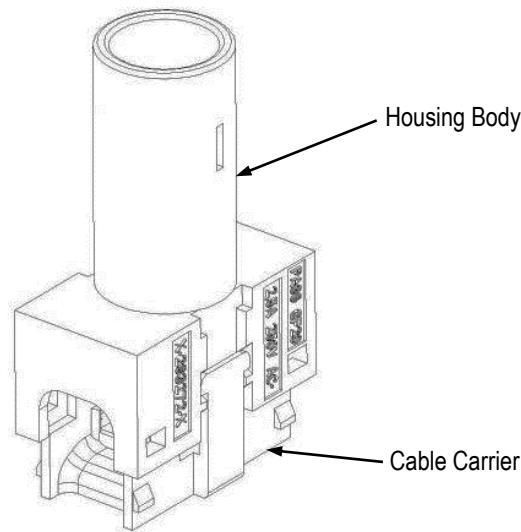

Figure 1

2. REFERENCE MATERIAL

2.1. Revision Summary

- Updated document to corporate requirements
- New layout and format
- New information for North America merged with European information throughout document

2.2. Customer Assistance

Reference Product Base Part Numbers 293270, 293300, and 2213222 and Product Codes K746 and L764 show the variations available for keying, mounting flange (tab), end vs. thru type, and sealing. Use of these numbers will identify the product line and help you to obtain product and tooling information. Such information can be obtained through a local TE Representative, by visiting our website at www.te.com, or by calling PRODUCT INFORMATION or the TOOLING ASSISTANCE CENTER at the numbers at the bottom of this page.

2.3. Drawings

Customer Drawings for product part numbers are available from our website at www.te.com. If there is a conflict between the information contained in the Customer Drawings and this specification or with any other technical documentation supplied, the information contained in the Customer Drawings takes priority.

2.4. Specifications

Product Specifications [108-20294](#) (North American version), and [108-94018](#) (European version), provides product performance and test results for the NECTOR S Connectors.

2.5. Instructional Material

Instruction sheets provide product assembly instructions or tool setup and operation procedures. Instruction sheets available that pertain to this product are:

- [411-18493](#) (Operating Instructions for Bus Bar Hand Tool 8-528441-7)
- [408-32179](#) (NECTOR S Bus Bar Connector)

3. REQUIREMENTS

3.1. Safety

Do not stack product shipping containers so high that the containers buckle or deform.

3.2. Storage

A. Ultraviolet Light

Prolonged exposure to ultraviolet light may deteriorate the chemical composition used in the product material.

B. Shelf Life

The product should remain in the shipping containers until ready for use to prevent deformation to components. The product should be used on a first in, first out basis to avoid storage contamination that could adversely affect performance.

C. Chemical Exposure

Do not store product near any chemical listed below as they may cause stress corrosion cracking in the material.

Alkalies	Ammonia	Citrates	Phosphates	Citrates	Sulfur Compounds
Amines	Carbonates	Nitrites	Sulfur Nitrites		Tartrates

3.3. Wire Selection and Preparation

These connectors will accept cables provided in the table in Figure 2. No preparation of the cables is required.

PART NUMBER SERIES	APPLICABLE CABLE
293270-[]	H03VVH2-F, 2 x 0.75 mm ²
293300-[]	
2213222-[]	SPT-2, 2/C 18 AWG Stranded

Figure 2

3.4. Termination Requirements

A. Cable Termination to NECTOR S Bus Bar Connectors



CAUTION

The cable carrier must always be gently pried off. Do NOT push the wire to be terminated through the opening of the connector body and cable carrier in the pre-staged position, otherwise damage may occur.

Two small screwdrivers can be used to gently pry the locking tabs of the cable carrier away to remove the cable carrier from the housing body. Care must be taken to avoid damaging the tabs on the cable carrier. See Figure 3.

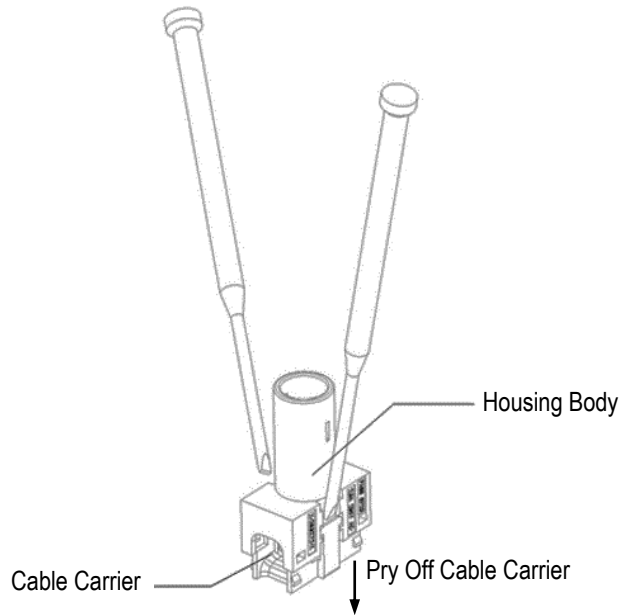

Figure 3

B. Positioning the Cable

Lay the cable to be tapped into the channel of the cable carrier.



CAUTION

Make sure that the cable is resting FLAT inside the channel to ensure the termination is successful. See Figure 4.

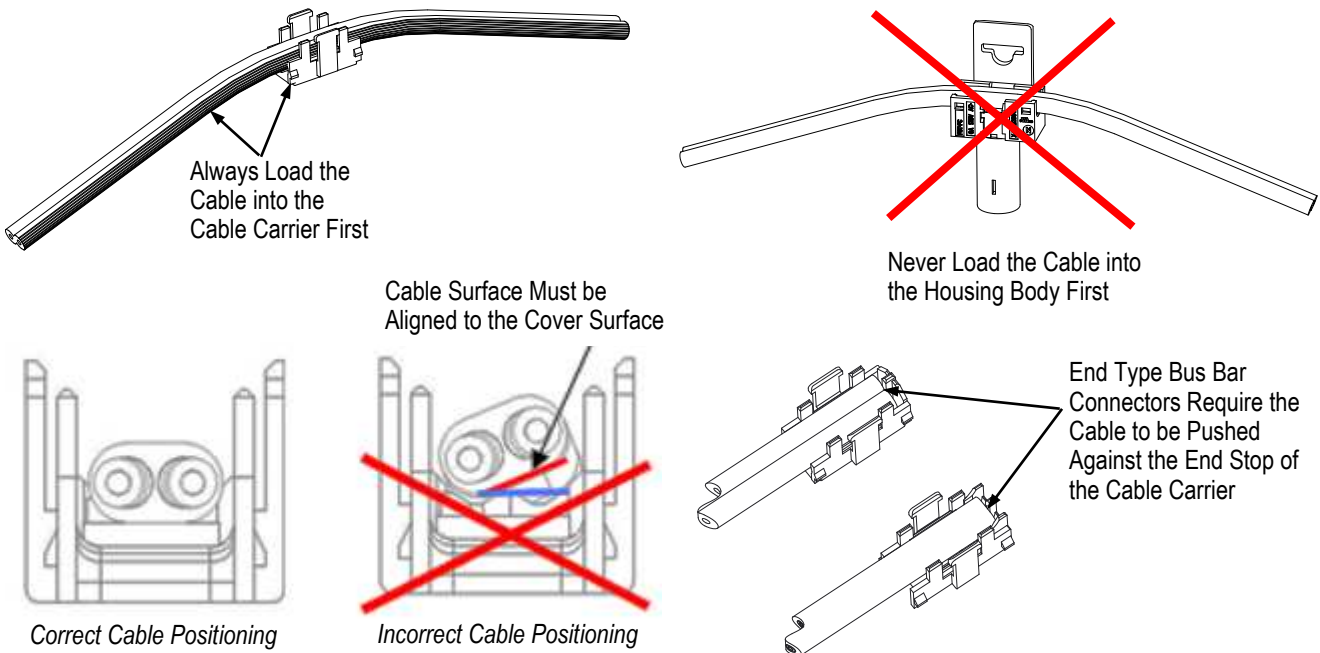

Figure 4

C. Housing Body

Install the housing body onto the cable carrier with the cable between the two parts until the locking tabs on the cable carrier engage with the locking ramp features on the housing body in the pre-stage position. See Figure 5.



CAUTION

Always note cable polarity conventions when placing the cable carrier into the pre-staged position. The striped/ribbed side of the cable is normally placed on the Neutral (N) or Negative (-) side of the bus bar connector.

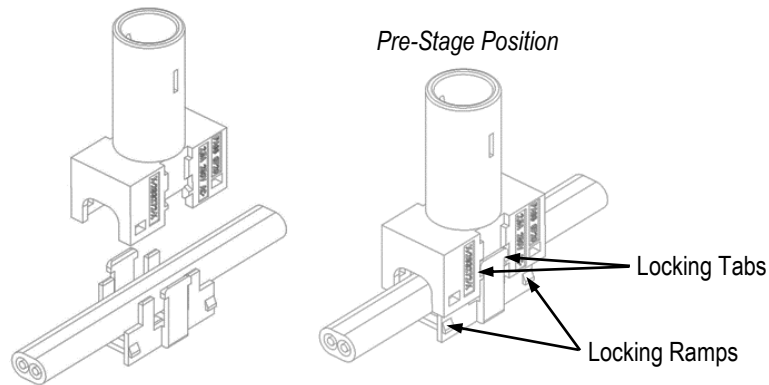
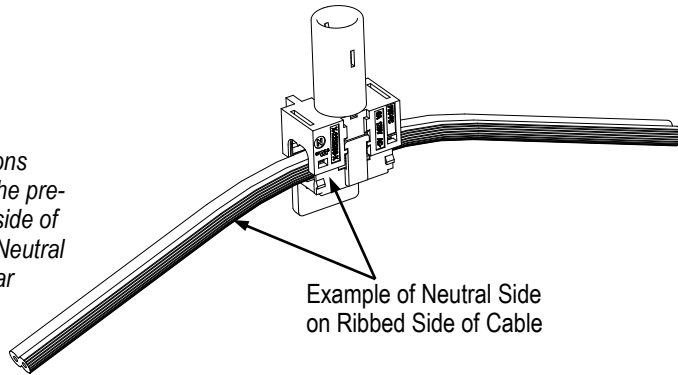

NOTE

Keep the cable flat in the cable carrier during this step.

Figure 5

D. Connector Termination



NOTE

Pre-form the cable to fit into the cable support feature while ensuring the cable remains flat in the cable carrier.

The cable to be terminated must be routed through the support features in the hand tool to ensure a good termination. Then, place the pre-staged connector into the TE hand tool (p/n 8-528441-7) and squeeze the handles fully to terminate the connector onto the cable. The handle on the tool must be fully depressed to release and remove the terminated connector assembly. See Figure 6.

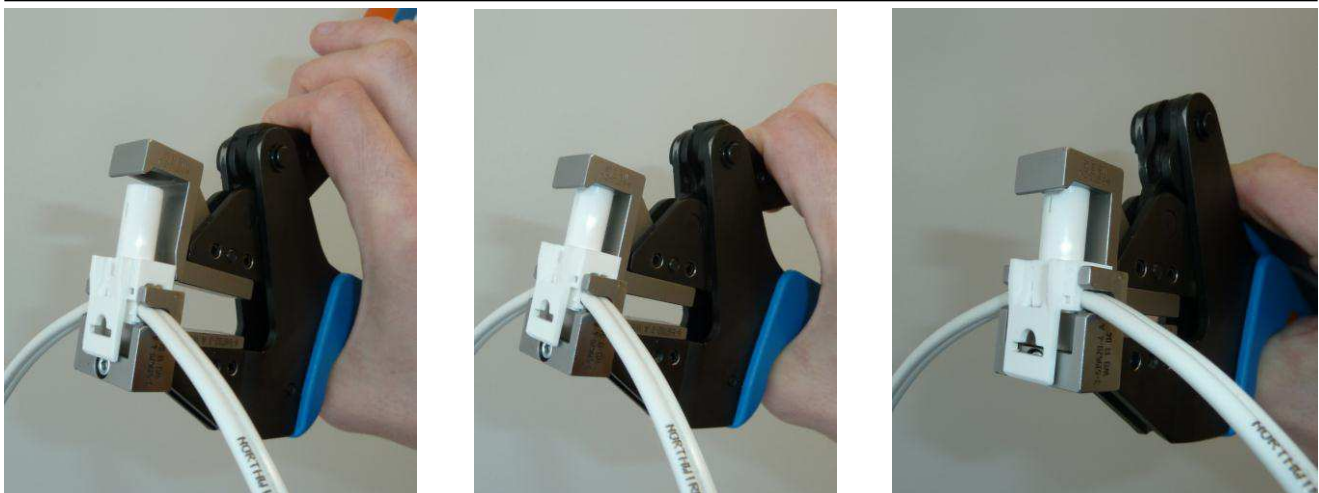
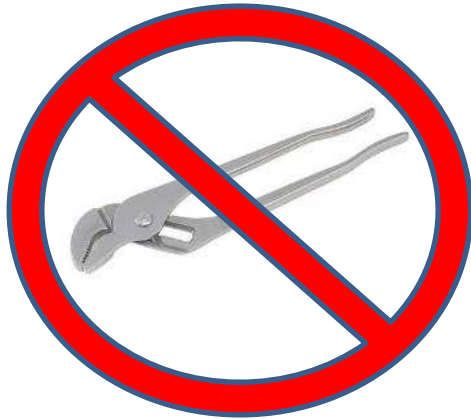

Figure 6



CAUTION

Terminating the NECTOR S Bus Bar connector with tooling other than the recommended TE hand tool can result in improperly terminated connectors. Additional details on the hand tool are available in Instruction Sheet 411-18493. If the TE hand tool is not used, the termination must be done using a tool with a parallel type action (an arbor press for example). When a non-TE tool is used to terminate this product, it is important to hold the cable flat in the cable carrier, while terminating. After termination, the latching features must be inspected to ensure that all latches on both sides of the bus bar connector are fully seated. This product cannot be properly terminated using standard single pivot type hand pliers. See Figure 7.



Arbor Press Termination

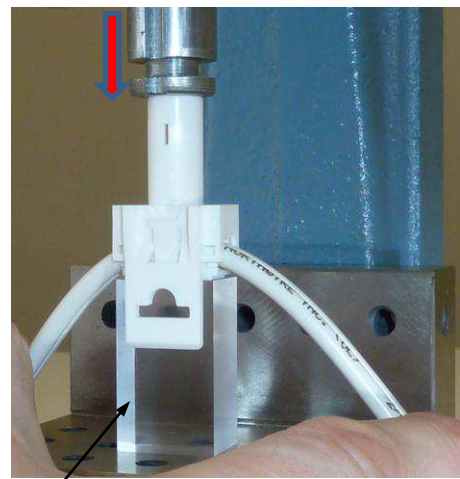
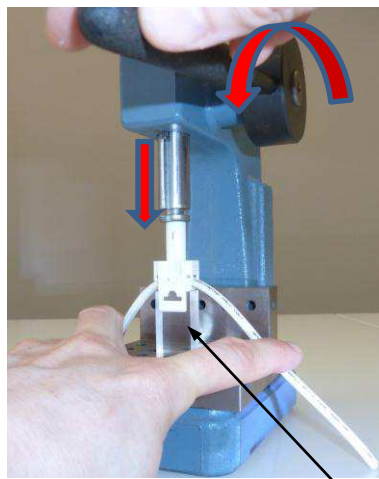

20-25 mm [.750-1.00 in.]
Wide Support Block Used
to Form Cable so it is
Held in the Cable Carrier
During Termination

Figure 7

E. Termination Inspection

Inspect the terminated connector to ensure all of the latch features on the connector housing body and cable carrier are fully seated. Verify the cable is flat in the termination area. A terminated connector assembly is not designed to be repaired. If the connector features are not properly seated or damaged, the connector must be removed and replaced with a newly terminated connector. See Figure 8.

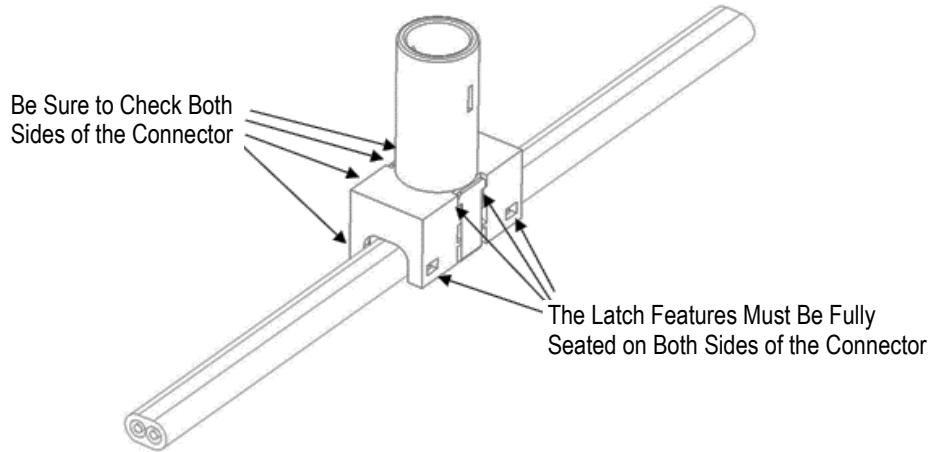
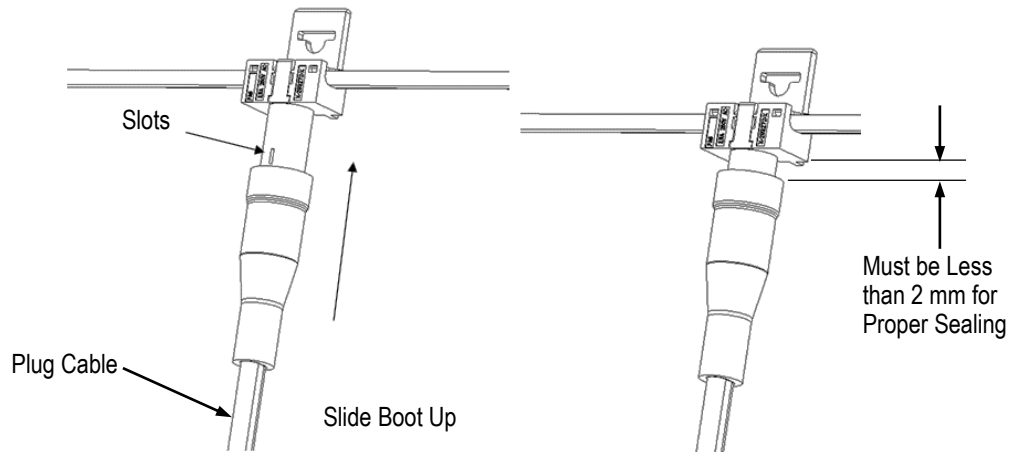

Figure 8

3.5. Ancillary Items

A. Sealing Boot

If the NECTOR S Bus Bar connector is a sealed version with the sealing gel inside the connector, the NECTOR S connector that plugs into the bottom of the bus bar connector must have a sealing boot to fully seal the assembly. The sealing boot must be the proper type per the options shown in the table in Figure 9. The boot must also be installed on the mating NECTOR S connector cable assembly before it is plugged into the bus bar connector. The boot needs to be pushed up over the slots in the bus bar barrel to be fully seated.



SEALING BOOT OPTIONS

SEALING BOOT PART NUMBER	PLUG CABLE TYPE	DIMENSIONS
2213211-1	SVT 2/C 18 AWG	5.59-6.48 mm OD
293284-1	H03VVH2-F, 2 x 0.75 mm ²	5.6 x 3.4 mm

Figure 9

B. Wall Outlet (Assembly into Customer Supplied Panel)

Wall outlet part numbers 293285-1 and 293286-[] can be used to mount the bus bar connector into a panel opening. The panel opening must be 75 x 35 +0.5/-0 mm. Panel thickness is to be 0.9 +0.1/-0. See Figure 10.

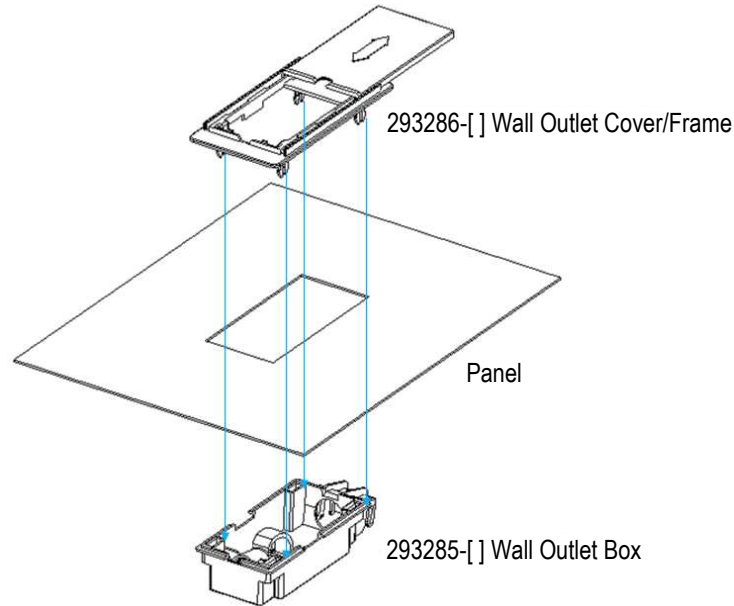

Figure 10

C. Wall Outlet (Assembly of Bus Bar Connector into Wall Outlet)

The bus bar connector is inserted into the wall outlet assembly by inserting the barrel end first and rotating it into position until it snaps together. The internal boot inside the wall outlet assembly can be used to plug the end of the bus bar connector if not being used right away. See Figure 11.

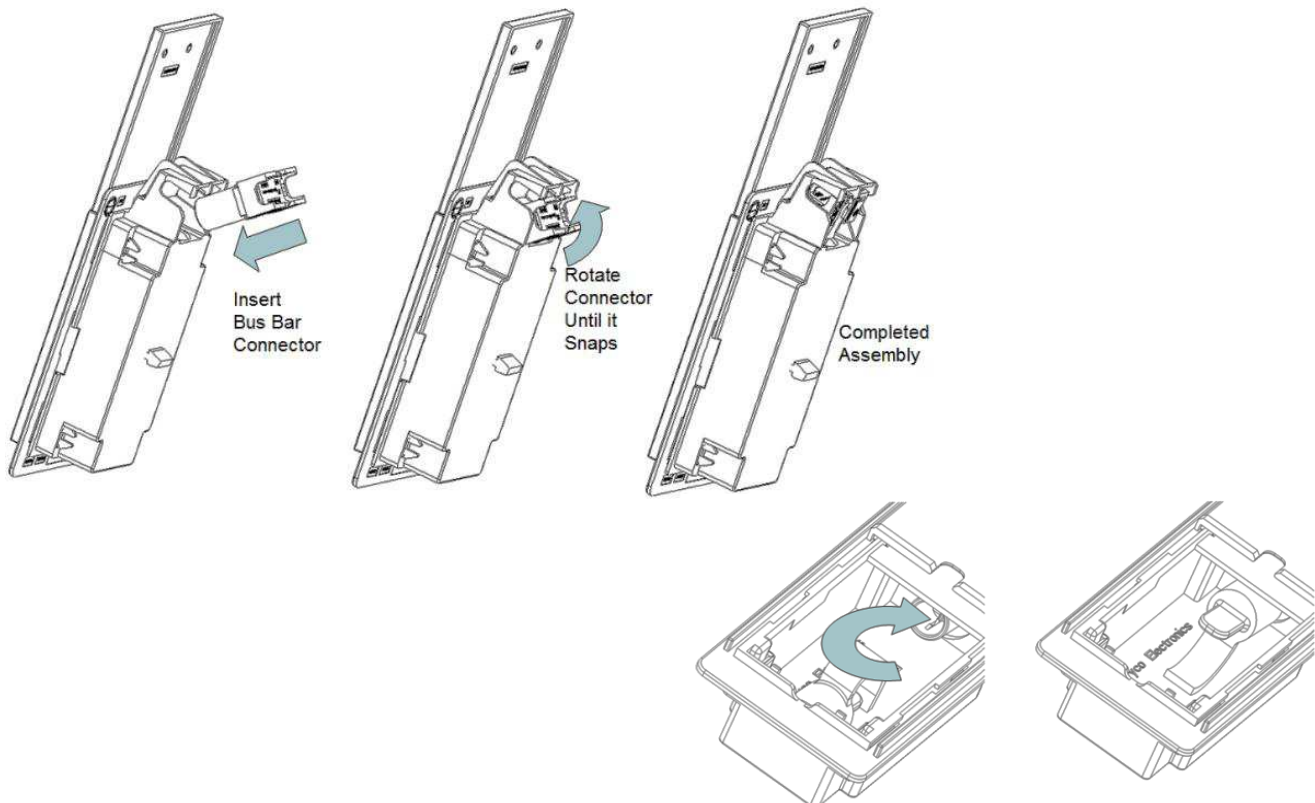

Figure 11

4. QUALIFICATION

No qualifying support was provided at time of publication of this document.

5. TOOLING

Tooling required for assembly and termination of this product are two small flat-bladed screwdrivers and TE Hand Tool (p/n 8-528441-7) with accompanying Instruction Sheet 411-18493.

6. VISUAL AID

The illustration below shows a typical application of this product. This illustration should be used by production personnel to ensure a correctly applied product. Applications which do not appear correct should be inspected using the information in the preceding pages of this specification and in the instructional material shipped with the product or tooling.

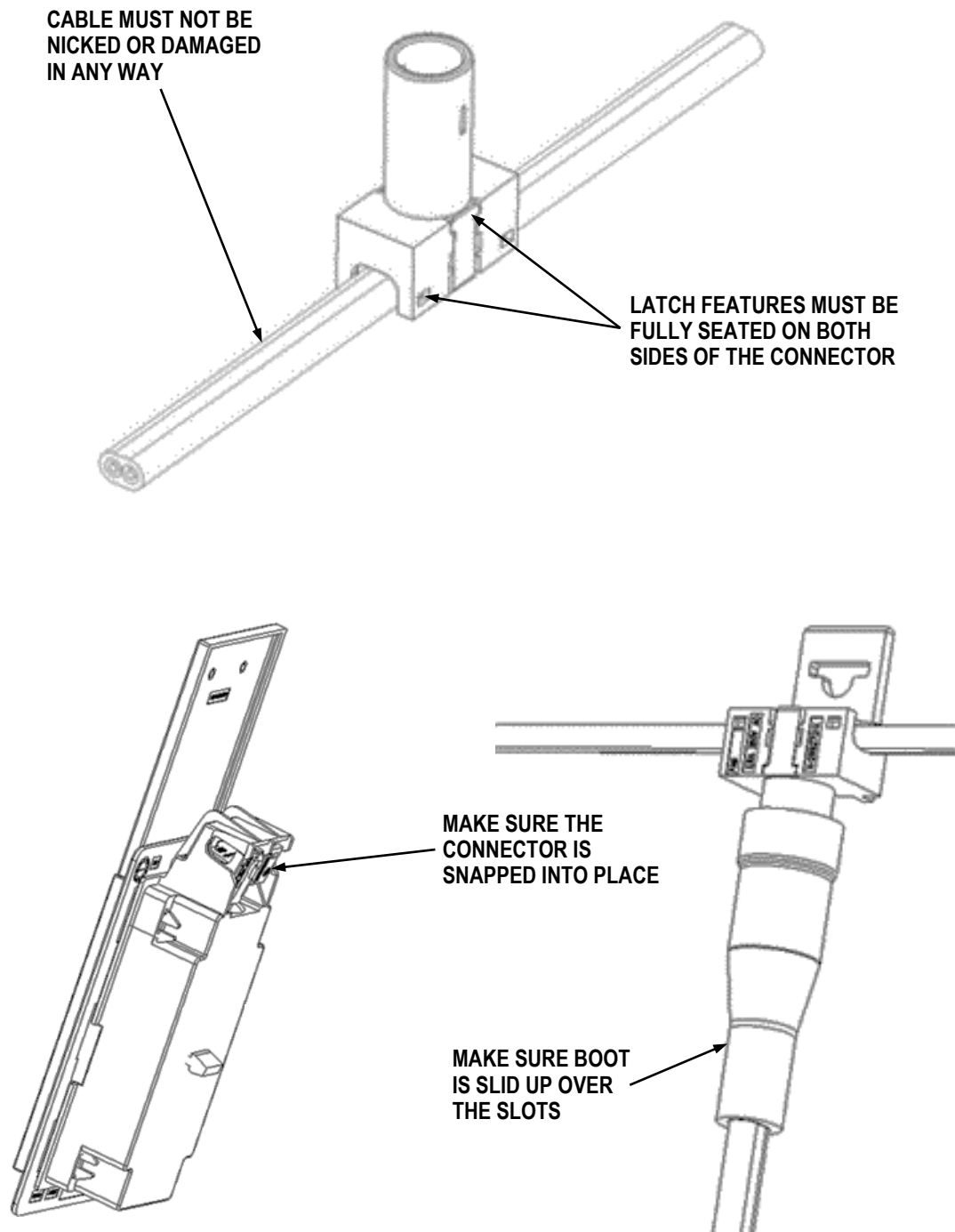

FIGURE 12. VISUAL AID

Данный компонент на территории Российской Федерации

Вы можете приобрести в компании MosChip.

Для оперативного оформления запроса Вам необходимо перейти по данной ссылке:

<http://moschip.ru/get-element>

Вы можете разместить у нас заказ для любого Вашего проекта, будь то серийное производство или разработка единичного прибора.

В нашем ассортименте представлены ведущие мировые производители активных и пассивных электронных компонентов.

Нашей специализацией является поставка электронной компонентной базы двойного назначения, продукции таких производителей как XILINX, Intel (ex.ALTERA), Vicor, Microchip, Texas Instruments, Analog Devices, Mini-Circuits, Amphenol, Glenair.

Сотрудничество с глобальными дистрибьюторами электронных компонентов, предоставляет возможность заказывать и получать с международных складов практически любой перечень компонентов в оптимальные для Вас сроки.

На всех этапах разработки и производства наши партнеры могут получить квалифицированную поддержку опытных инженеров.

Система менеджмента качества компании отвечает требованиям в соответствии с ГОСТ Р ИСО 9001, ГОСТ РВ 0015-002 и ЭС РД 009

Офис по работе с юридическими лицами:

105318, г.Москва, ул.Щербаковская д.3, офис 1107, 1118, ДЦ «Щербаковский»

Телефон: +7 495 668-12-70 (многоканальный)

Факс: +7 495 668-12-70 (доб.304)

E-mail: info@moschip.ru

Skype отдела продаж:

moschip.ru

moschip.ru_4

moschip.ru_6

moschip.ru_9