

Type 4, 4X Mild Steel and Stainless Steel Consolelet *Series 2000*

Modular Console System



Application

- Serves as an economical housing for operator interface applications.
- Provides an ideal sloped surface for mounting keyboards, switches, indicator lights, and/or dials.
- Provides panel mounting capabilities for a variety of applications. Generally used as a stand alone enclosure. Possible to put side by side with base on a single plinth (ie. 36" wide consolelet with 24" base with terminal all together on a 60" plinth).
- Optional casters (require plinth) allow for a completely mobile, NEMA rated work station.
- Smooth lines and clean edges provide an attractive, contemporary appearance.

Standards

- UL 508 Type 3R, 4,12
- CSA Type 3R, 4, 12, 13
- EIA RS-310-D
- Complies with
 - NEMA Type 3R, 4, 12
 - IEC 60529, IP66

Construction

- UL 508 Type 3R, 4, 4X, 12
- CSA Type 3R, 4, 4X, 12
- Complies with
 - NEMA Type 3R, 4, 4X, 12
 - IEC 60529, IP66

Finish

- Formed 14 gauge steel bodies with 14 gauge steel door and lid.
- Also offered with formed 14 gauge 304 stainless steel bodies with 14 gauge 304 stainless steel door and lid.
- Smooth, continuously welded seams without knockouts or holes.
- Body stiffeners are provided where required for increased strength and rigidity.
- Offered in 4 widths 24", 36", 48" and 60".
- Has solid sides and back, solid door on front, 3 point adjustable lid on sloped (20°) top, and closed bottom with removable access panel.
- 24" and 36" widths have single door on the front whereas 48" and 60" widths have two outside hinged doors on the front.
- Doors can be hinged from either side on 24" and 36" units.
- Door profiles provide increased strength and are pre-punched to provide mounting options.

- Formed lip on enclosure excludes flowing liquids and contaminants.
- Slotted quarter turn oil-tight latches secure the door and lid, with optional tamper resistant and locking latches available.
- Stainless steel models utilize stainless steel hardware.
- Oil resistant gaskets are permanently secured and mechanically retained.
- Features internal stud locations for mounting optional inner panel.
- A bonding screw is provided on the door and a grounding stud is provided in the enclosure.

Accessories

- Available in RAL 7035 light gray textured powder coating and natural stainless steel with a smooth, brushed finish.

Accessories

Cooling Products

Filtered Fans

Heaters

Modular Plinth

Mobile Keyboard Support

- Blowers and Fans
- Rack Mount Fan Tray
- Footrest
- Consolet Panel

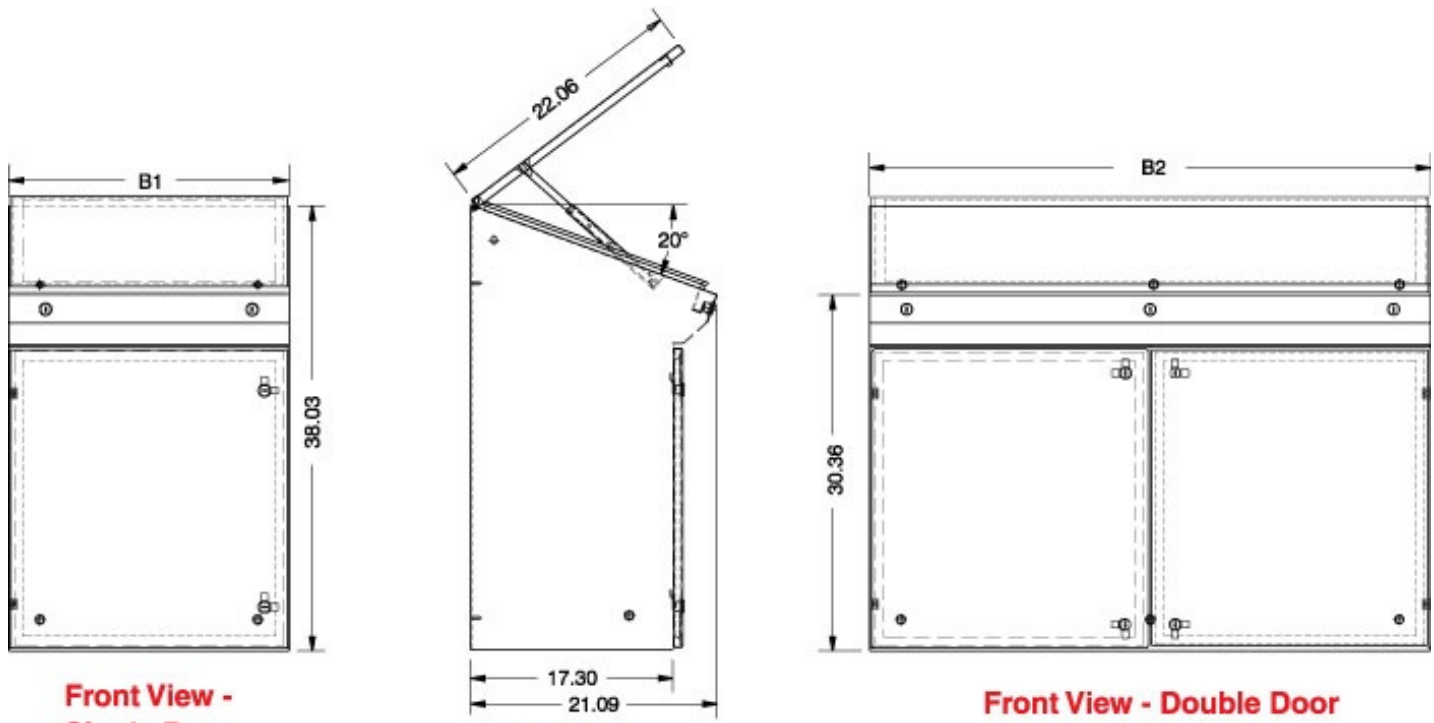

**Front View -
Single Door**

**Side View
(Either)**

Front View - Double Door

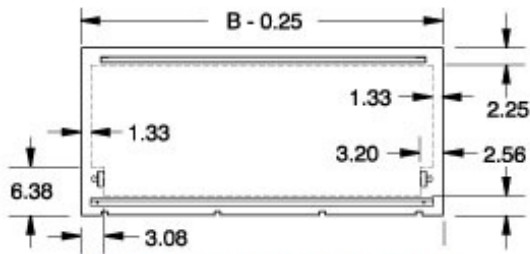

**Enlarged Inside View of
Door on Sloped Surface
(Either)**

RAL 7035 Light Gray Part No.	Stainless Steel Part No.	B1	B2
2CLC2024	2CSC2024	24.00	-
2CLC2036	2CSC2036	36.00	-
2CLC2048	2CSC2048	-	48.00
2CLC2060	2CSC2060	-	60.00

Data subject to change without notice.

Данный компонент на территории Российской Федерации

Вы можете приобрести в компании MosChip.

Для оперативного оформления запроса Вам необходимо перейти по данной ссылке:

<http://moschip.ru/get-element>

Вы можете разместить у нас заказ для любого Вашего проекта, будь то серийное производство или разработка единичного прибора.

В нашем ассортименте представлены ведущие мировые производители активных и пассивных электронных компонентов.

Нашей специализацией является поставка электронной компонентной базы двойного назначения, продукции таких производителей как XILINX, Intel (ex.ALTERA), Vicor, Microchip, Texas Instruments, Analog Devices, Mini-Circuits, Amphenol, Glenair.

Сотрудничество с глобальными дистрибьюторами электронных компонентов, предоставляет возможность заказывать и получать с международных складов практически любой перечень компонентов в оптимальные для Вас сроки.

На всех этапах разработки и производства наши партнеры могут получить квалифицированную поддержку опытных инженеров.

Система менеджмента качества компании отвечает требованиям в соответствии с ГОСТ Р ИСО 9001, ГОСТ РВ 0015-002 и ЭС РД 009

Офис по работе с юридическими лицами:

105318, г.Москва, ул.Щербаковская д.3, офис 1107, 1118, ДЦ «Щербаковский»

Телефон: +7 495 668-12-70 (многоканальный)

Факс: +7 495 668-12-70 (доб.304)

E-mail: info@moschip.ru

Skype отдела продаж:

moschip.ru

moschip.ru_4

moschip.ru_6

moschip.ru_9