

74HC4017-Q100; 74HCT4017-Q100

Johnson decade counter with 10 decoded outputs

Rev. 2 — 1 July 2020

Product data sheet

1. General description

The 74HC4017-Q100; 74HCT4017-Q100 is a 5-stage Johnson decade counter with 10 decoded outputs (Q0 to Q9), an output from the most significant flip-flop ($\overline{Q}5-9$), two clock inputs (CP0 and $\overline{CP}1$) and an overriding asynchronous master reset input (MR). The counter is advanced by either a LOW-to-HIGH transition at CP0 while $\overline{CP}1$ is LOW or a HIGH-to-LOW transition at $\overline{CP}1$ while CP0 is HIGH. When cascading counters, the $\overline{Q}5-9$ output, which is LOW while the counter is in states 5, 6, 7, 8 and 9, can be used to drive the CP0 input of the next counter. A HIGH on MR resets the counter to zero (Q0 = $\overline{Q}5-9$ = HIGH; Q1 to Q9 = LOW) independent of the clock inputs (CP0 and $\overline{CP}1$). Automatic code correction of the counter is provided by an internal circuit: following any illegal code the counter returns to a proper counting mode within 11 clock pulses. Inputs include clamp diodes. This enables the use of current limiting resistors to interface inputs to voltages in excess of V_{CC} .

This product has been qualified to the Automotive Electronics Council (AEC) standard Q100 (Grade 1) and is suitable for use in automotive applications.

2. Features and benefits

- Automotive product qualification in accordance with AEC-Q100 (Grade 1)
 - Specified from -40 °C to +85 °C and from -40 °C to +125 °C
- Wide supply voltage range from 2.0 V to 6.0 V
- CMOS low power dissipation
- High noise immunity
- Latch-up performance exceeds 100 mA per JESD 78 Class II Level B
- Complies with JEDEC standards:
 - JESD8C (2.7 V to 3.6 V)
 - JESD7A (2.0 V to 6.0 V)
- Input levels:
 - For 74HC4017-Q100: CMOS level
 - For 74HCT4017-Q100: TTL level
- ESD protection:
 - MIL-STD-883, method 3015 exceeds 2000 V
 - HBM JESD22-A114F exceeds 2000 V
 - MM JESD22-A115-A exceeds 200 V (C = 200 pF, R = 0 Ω)
- Multiple package options
- DHVQFN package with Side-Wettable Flanks enabling Automatic Optical Inspection (AOI) of solder joints

3. Ordering information

Table 1. Ordering information

Type number	Package			Version
	Temperature range	Name	Description	
74HC4017D-Q100 74HCT4017D-Q100	-40 °C to +125 °C	SO16	plastic small outline package; 16 leads; body width 3.9 mm	SOT109-1
74HC4017PW-Q100	-40 °C to +125 °C	TSSOP16	plastic thin shrink small outline package; 16 leads; body width 4.4 mm	SOT403-1
74HC4017BQ-Q100 74HCT4017BQ-Q100	-40 °C to +125 °C	DHVQFN16	plastic dual in-line compatible thermal enhanced very thin quad flat package; no leads; 16 terminals; body 2.5 × 3.5 × 0.85 mm	SOT763-1

4. Functional diagram

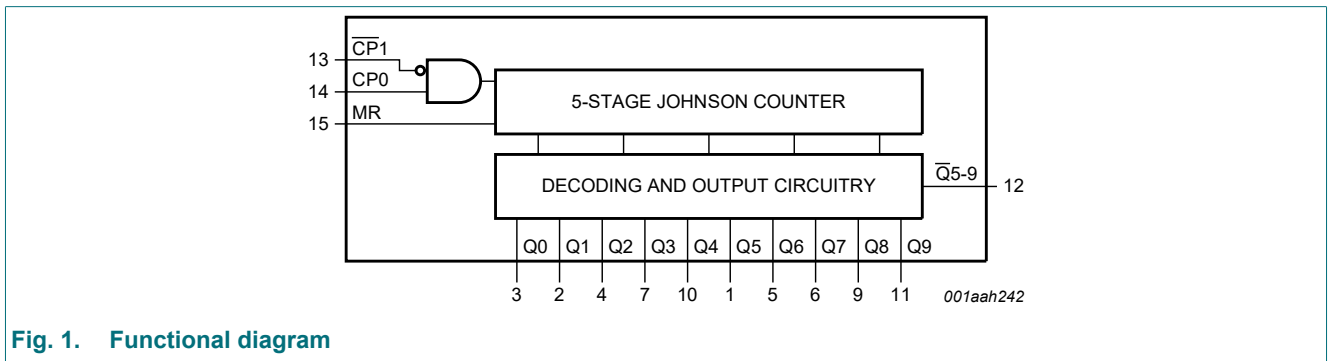

Fig. 1. Functional diagram

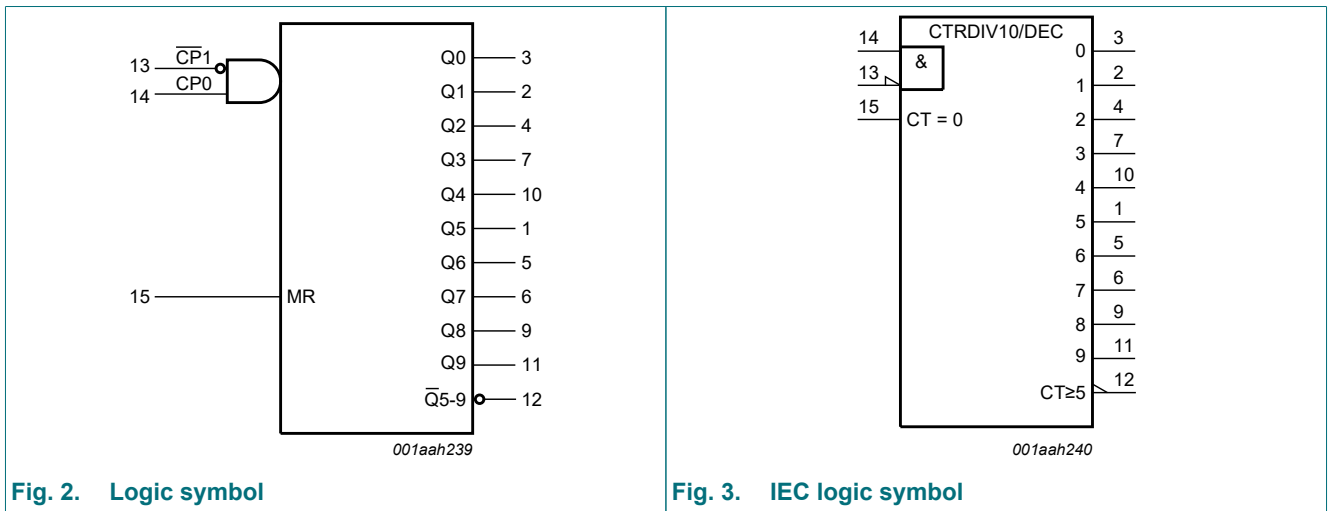

Fig. 2. Logic symbol

Fig. 3. IEC logic symbol

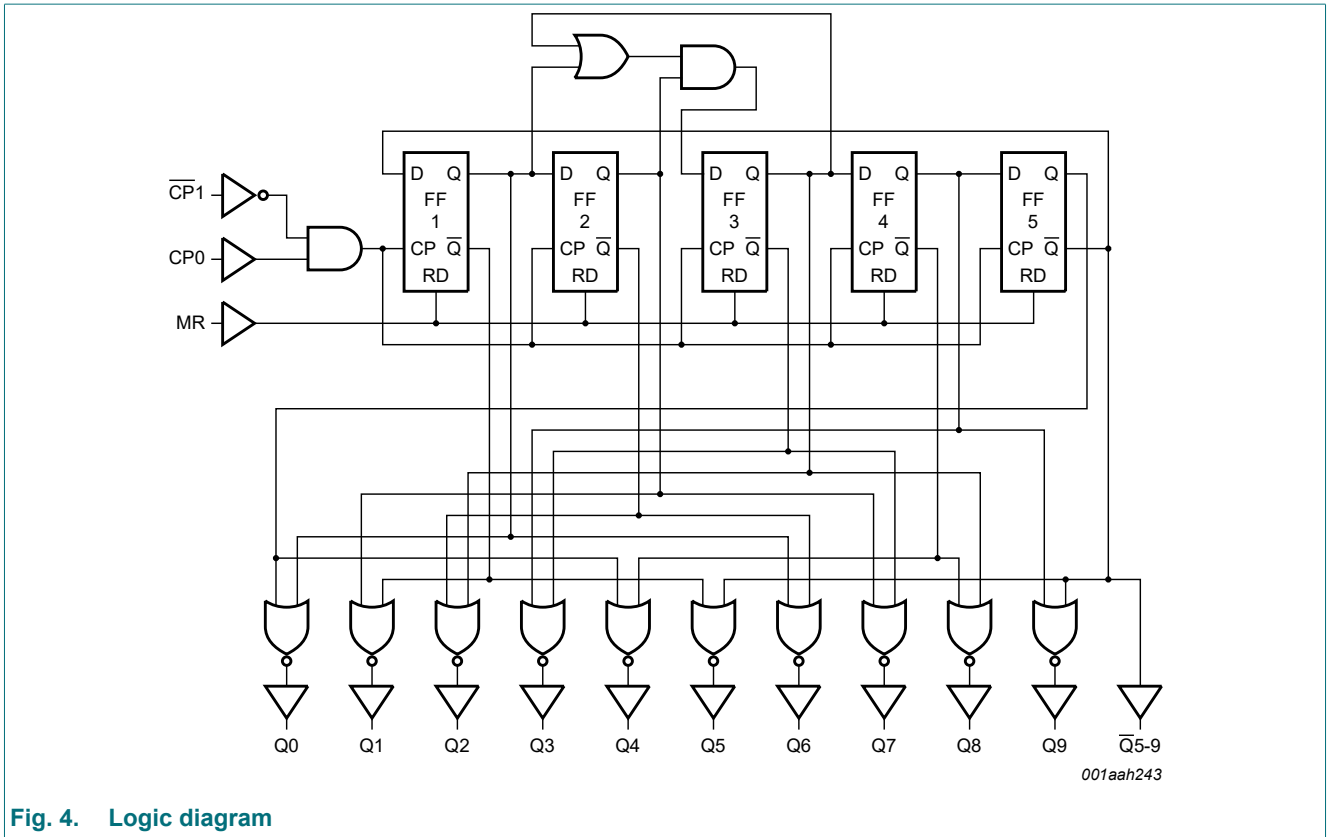

Fig. 4. Logic diagram

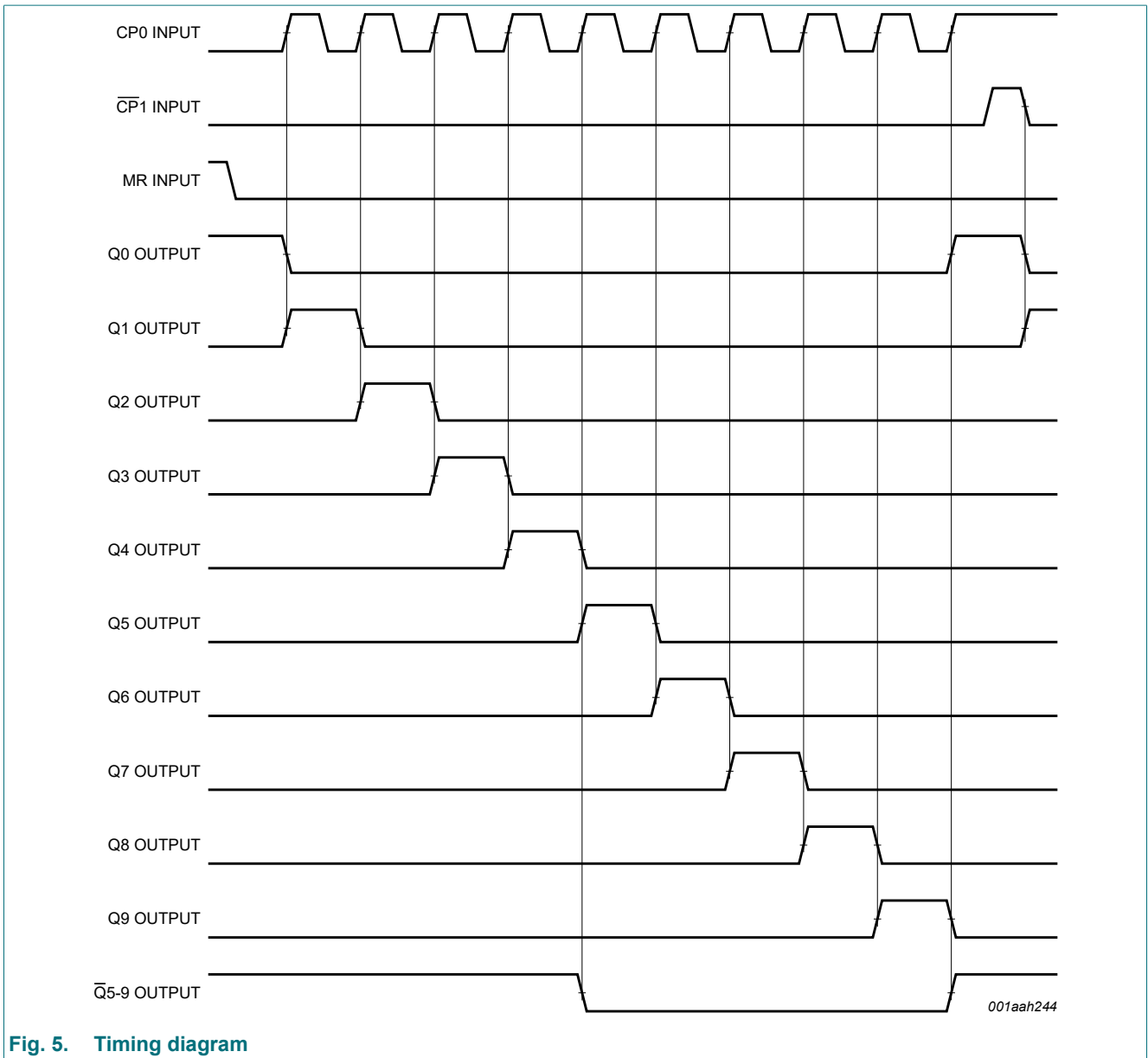
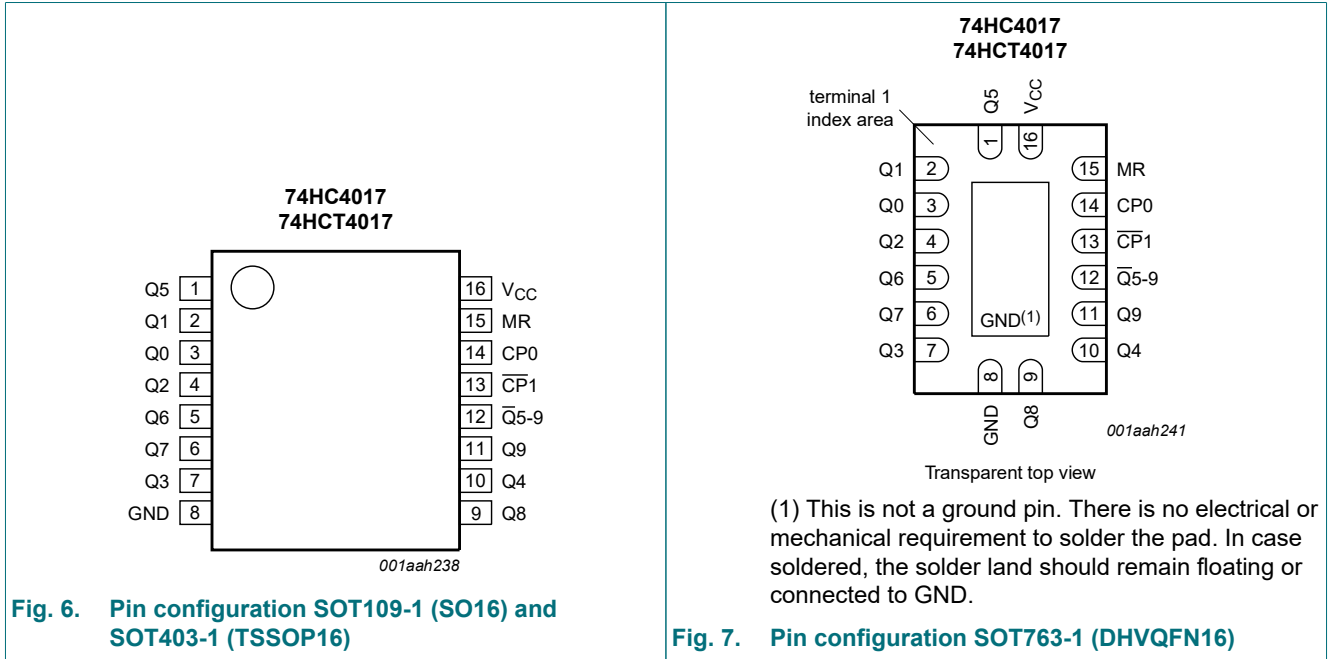

Fig. 5. Timing diagram

5. Pinning information

5.1. Pinning



5.2. Pin description

Table 2. Pin description

Symbol	Pin	Description
Q0, Q1, Q2, Q3, Q4, Q5, Q6, Q7, Q8, Q9	3, 2, 4, 7, 10, 1, 5, 6, 9, 11	decoded output
GND	8	ground (0 V)
Q̄5-9	12	carry output (active LOW)
CP1	13	clock input (HIGH-to-LOW edge-triggered)
CP0	14	clock input (LOW-to-HIGH edge-triggered)
MR	15	master reset input (active HIGH)
V _{CC}	16	supply voltage

6. Functional description

Table 3. Function table

H = HIGH voltage level; L = LOW voltage level; X = don't care; ↑ = LOW-to-HIGH transition; ↓ = HIGH-to-LOW transition;

MR	CP0	CP1	Operation
H	X	X	Q0 = Q5-9 = HIGH; Q1 to Q9 = LOW
L	H	↓	counter advances
L	↑	L	counter advances
L	L	X	no change
L	X	H	no change
L	H	↑	no change
L	↓	L	no change

7. Limiting values

Table 4. Limiting values

In accordance with the Absolute Maximum Rating System (IEC 60134). Voltages are referenced to GND (ground = 0 V).

Symbol	Parameter	Conditions	Min	Max	Unit
V _{CC}	supply voltage		-0.5	+7	V
I _{IK}	input clamping current	V _I < -0.5 V or V _I > V _{CC} + 0.5 V [1]	-	±20	mA
I _{OK}	output clamping current	V _O < -0.5 V or V _O > V _{CC} + 0.5 V [1]	-	±20	mA
I _O	output current	-0.5 V < V _O < V _{CC} + 0.5 V	-	±25	mA
I _{CC}	supply current		-	50	mA
I _{GND}	ground current		-50	-	mA
T _{stg}	storage temperature		-65	+150	°C
P _{tot}	total power dissipation	T _{amb} = -40 °C to +125 °C [2]	-	500	mW

[1] The input and output voltage ratings may be exceeded if the input and output current ratings are observed.

[2] For SOT109-1 (SO16) package: P_{tot} derates linearly with 12.4 mW/K above 110 °C.
 For SOT403-1 (TSSOP16) package: P_{tot} derates linearly with 8.5 mW/K above 91 °C.
 For SOT763-1 (DHVQFN16) package: P_{tot} derates linearly with 11.2 mW/K above 106 °C.

8. Recommended operating conditions

Table 5. Recommended operating conditions

Symbol	Parameter	Conditions	74HC4017-Q100			74HCT4017-Q100			Unit
			Min	Typ	Max	Min	Typ	Max	
V _{CC}	supply voltage		2.0	5.0	6.0	4.5	5.0	5.5	V
V _I	input voltage		0	-	V _{CC}	0	-	V _{CC}	V
V _O	output voltage		0	-	V _{CC}	0	-	V _{CC}	V
Δt/ΔV	input transition rise and fall rate	V _{CC} = 2.0 V	-	-	625	-	-	-	ns/V
		V _{CC} = 4.5 V	-	1.67	139	-	1.67	139	ns/V
		V _{CC} = 6.0 V	-	-	83	-	-	-	ns/V
T _{amb}	ambient temperature		-40	+25	+125	-40	+25	+125	°C

9. Static characteristics

Table 6. Static characteristics

At recommended operating conditions; voltages are referenced to GND (ground = 0 V).

Symbol	Parameter	Conditions	25 °C			-40 °C to +85 °C		-40 °C to +125 °C		Unit
			Min	Typ	Max	Min	Max	Min	Max	
74HC4017-Q100										
V _{IH}	HIGH-level input voltage	V _{CC} = 2.0 V	1.5	1.2	-	1.5	-	1.5	-	V
		V _{CC} = 4.5 V	3.15	2.4	-	3.15	-	3.15	-	V
		V _{CC} = 6.0 V	4.2	3.2	-	4.2	-	4.2	-	V
V _{IL}	LOW-level input voltage	V _{CC} = 2.0 V	-	0.8	0.5	-	0.5	-	0.5	V
		V _{CC} = 4.5 V	-	2.1	1.35	-	1.35	-	1.35	V
		V _{CC} = 6.0 V	-	2.8	1.8	-	1.8	-	1.8	V
V _{OH}	HIGH-level output voltage	V _I = V _{IH} or V _{IL}								
		I _O = -20 μA; V _{CC} = 2.0 V	1.9	2.0	-	1.9	-	1.9	-	V
		I _O = -20 μA; V _{CC} = 4.5 V	4.4	4.5	-	4.4	-	4.4	-	V
		I _O = -20 μA; V _{CC} = 6.0 V	5.9	6.0	-	5.9	-	5.9	-	V
		I _O = -4.0 mA; V _{CC} = 4.5 V	3.98	4.32	-	3.84	-	3.7	-	V
		I _O = -5.2 mA; V _{CC} = 6.0 V	5.48	5.81	-	5.34	-	5.2	-	V
V _{OL}	LOW-level output voltage	V _I = V _{IH} or V _{IL}								
		I _O = 20 μA; V _{CC} = 2.0 V	-	0	0.1	-	0.1	-	0.1	V
		I _O = 20 μA; V _{CC} = 4.5 V	-	0	0.1	-	0.1	-	0.1	V
		I _O = 20 μA; V _{CC} = 6.0 V	-	0	0.1	-	0.1	-	0.1	V
		I _O = 4.0 mA; V _{CC} = 4.5 V	-	0.15	0.26	-	0.33	-	0.4	V
		I _O = 5.2 mA; V _{CC} = 6.0 V	-	0.16	0.26	-	0.33	-	0.4	V
I _I	input leakage current	V _I = V _{CC} or GND; V _{CC} = 6.0 V	-	-	±0.1	-	±1.0	-	±1.0	μA
I _{CC}	supply current	V _I = V _{CC} or GND; I _O = 0 A; V _{CC} = 6.0 V	-	-	8.0	-	80	-	160	μA
C _I	input capacitance		-	3.5	-	-	-	-	-	pF

Symbol	Parameter	Conditions	25 °C			-40 °C to +85 °C		-40 °C to +125 °C		Unit
			Min	Typ	Max	Min	Max	Min	Max	
74HCT4017-Q100										
V _{IH}	HIGH-level input voltage	V _{CC} = 4.5 V to 5.5 V	2.0	1.6	-	2.0	-	2.0	-	V
V _{IL}	LOW-level input voltage	V _{CC} = 4.5 V to 5.5 V	-	1.2	0.8	-	0.8	-	0.8	V
V _{OH}	HIGH-level output voltage	V _I = V _{IH} or V _{IL} ; V _{CC} = 4.5 V								
		I _O = -20 µA	4.4	4.5	-	4.4	-	4.4	-	V
		I _O = -4 mA	3.98	4.32	-	3.84	-	3.7	-	V
V _{OL}	LOW-level output voltage	V _I = V _{IH} or V _{IL} ; V _{CC} = 4.5 V								
		I _O = 20 µA	-	0	0.1	-	0.1	-	0.1	V
		I _O = 4.0 mA	-	0.15	0.26	-	0.33	-	0.4	V
I _I	input leakage current	V _I = V _{CC} or GND; V _{CC} = 5.5 V	-	-	±0.1	-	±1.0	-	±1.0	µA
I _{CC}	supply current	V _I = V _{CC} or GND; V _{CC} = 5.5 V; I _O = 0 A	-	-	8.0	-	80	-	160	µA
ΔI _{CC}	additional supply current	per input pin; V _I = V _{CC} - 2.1 V; other inputs at V _{CC} or GND; V _{CC} = 4.5 V to 5.5 V; I _O = 0 A								
		CP0 input	-	25	90	-	113	-	123	µA
		$\overline{\text{CP}}1$ input	-	40	144	-	180	-	196	µA
		MR input	-	50	180	-	225	-	245	µA
C _I	input capacitance		-	3.5	-	-	-	-	-	pF

10. Dynamic characteristics

Table 7. Dynamic characteristics

$GND = 0\text{ V}$; $t_r = t_f = 6\text{ ns}$; $C_L = 50\text{ pF}$; see [Fig. 11](#).

Symbol	Parameter	Conditions	25 °C			-40 °C to +85 °C		-40 °C to +125 °C		Unit
			Min	Typ	Max	Min	Max	Min	Max	
74HC4017-Q100										
t_{pd}	propagation delay	CP0 to Qn; CP0 to $\overline{Q}5-9$; see Fig. 8 [1]								
		$V_{CC} = 2.0\text{ V}$	-	63	230	-	290	-	345	ns
		$V_{CC} = 4.5\text{ V}$	-	23	46	-	58	-	69	ns
		$V_{CC} = 5.0\text{ V}$; $C_L = 15\text{ pF}$	-	20	-	-	-	-	-	ns
		$V_{CC} = 6.0\text{ V}$	-	18	39	-	49	-	59	ns
		$\overline{CP}1$ to Qn; $\overline{CP}1$ to $\overline{Q}5-9$; see Fig. 8								
		$V_{CC} = 2.0\text{ V}$	-	61	250	-	315	-	375	ns
		$V_{CC} = 4.5\text{ V}$	-	22	50	-	63	-	75	ns
t_{PHL}	HIGH to LOW propagation delay	MR to Qn; see Fig. 9								
		$V_{CC} = 2.0\text{ V}$	-	52	230	-	290	-	345	ns
		$V_{CC} = 4.5\text{ V}$	-	19	46	-	58	-	69	ns
t_{PLH}	LOW to HIGH propagation delay	MR to $\overline{Q}5-9$, Q0; see Fig. 9								
		$V_{CC} = 2.0\text{ V}$	-	55	230	-	290	-	345	ns
		$V_{CC} = 4.5\text{ V}$	-	20	46	-	58	-	69	ns
t_t	transition time	see Fig. 8 [2]								
		$V_{CC} = 2.0\text{ V}$	-	19	75	-	95	-	110	ns
		$V_{CC} = 4.5\text{ V}$	-	7	15	-	19	-	22	ns
t_w	pulse width	CP0 and $\overline{CP}1$ (HIGH or LOW); see Fig. 9								
		$V_{CC} = 2.0\text{ V}$	80	17	-	100	-	120	-	ns
		$V_{CC} = 4.5\text{ V}$	16	6	-	20	-	24	-	ns
		$V_{CC} = 6.0\text{ V}$	14	5	-	17	-	20	-	ns
		MR (HIGH); see Fig. 9								
		$V_{CC} = 2.0\text{ V}$	80	19	-	100	-	120	-	ns
		$V_{CC} = 4.5\text{ V}$	16	7	-	20	-	24	-	ns
t_{su}	set-up time	$\overline{CP}1$ to CP0; CP0 to $\overline{CP}1$; see Fig. 10								
		$V_{CC} = 2.0\text{ V}$	50	-8	-	65	-	75	-	ns
		$V_{CC} = 4.5\text{ V}$	10	-3	-	13	-	15	-	ns
		$V_{CC} = 6.0\text{ V}$	9	-2	-	11	-	13	-	ns

Symbol	Parameter	Conditions	25 °C			-40 °C to +85 °C		-40 °C to +125 °C		Unit	
			Min	Typ	Max	Min	Max	Min	Max		
t _h	hold time	$\overline{CP1}$ to CP0; CP0 to $\overline{CP1}$; see Fig. 10									
		V _{CC} = 2.0 V	50	17	-	65	-	75	-	ns	
		V _{CC} = 4.5 V	10	6	-	13	-	15	-	ns	
		V _{CC} = 6.0 V	9	5	-	11	-	13	-	ns	
t _{rec}	recovery time	MR to CP0 and MR to $\overline{CP1}$; see Fig. 9									
		V _{CC} = 2.0 V	5	-17	-	5	-	5	-	ns	
		V _{CC} = 4.5 V	5	-6	-	5	-	5	-	ns	
		V _{CC} = 6.0 V	5	-5	-	5	-	5	-	ns	
f _{max}	maximum frequency	CP0 or $\overline{CP1}$; see Fig. 9									
		V _{CC} = 2.0 V	6.0	23	-	4.8	-	4.0	-	MHz	
		V _{CC} = 4.5 V	30	70	-	24	-	20	-	MHz	
		V _{CC} = 5.0 V; C _L = 15 pF	-	77	-	-	-	-	-	MHz	
		V _{CC} = 6.0 V	25	83	-	28	-	24	-	MHz	
C _{PD}	power dissipation capacitance	V _I = GND to V _{CC} ; V _{CC} = 5 V; [3] f _i = 1 MHz	-	35	-	-	-	-	-	pF	
74HCT4017-Q100											
t _{pd}	propagation delay	CP0 to Q _n ; CP0 to $\overline{Q5-9}$; see Fig. 8 [1]									
		V _{CC} = 4.5 V	-	25	46	-	58	-	69	ns	
		V _{CC} = 5.0 V; C _L = 15 pF	-	21	-	-	-	-	-	ns	
		$\overline{CP1}$ to Q _n ; $\overline{CP1}$ to $\overline{Q5-9}$; see Fig. 8									
		V _{CC} = 4.5 V	-	25	50	-	63	-	75	ns	
		V _{CC} = 5.0 V; C _L = 15 pF	-	21	-	-	-	-	-	ns	
t _{PHL}	HIGH to LOW propagation delay	MR to Q _n ; see Fig. 9									
		V _{CC} = 4.5 V	-	22	46	-	58	-	69	ns	
t _{PLH}	LOW to HIGH propagation delay	MR to $\overline{Q5-9}$, Q0; see Fig. 9									
		V _{CC} = 4.5 V	-	20	46	-	58	-	69	ns	
t _t	transition time	see Fig. 8 [2]									
		V _{CC} = 4.5 V	-	7	15	-	19	-	22	ns	
t _W	pulse width	CP0 and $\overline{CP1}$ (HIGH or LOW); see Fig. 9									
		V _{CC} = 4.5 V	16	7	-	20	-	24	-	ns	
		MR (HIGH); see Fig. 9									
		V _{CC} = 4.5 V	16	4	-	20	-	24	-	ns	
t _{su}	set-up time	$\overline{CP1}$ to CP0; CP0 to $\overline{CP1}$; see Fig. 10									
		V _{CC} = 4.5 V	10	-3	-	13	-	15	-	ns	
t _h	hold time	$\overline{CP1}$ to CP0; CP0 to $\overline{CP1}$; see Fig. 10									
		V _{CC} = 4.5 V	10	6	-	13	-	15	-	ns	

Symbol	Parameter	Conditions	25 °C			-40 °C to +85 °C		-40 °C to +125 °C		Unit
			Min	Typ	Max	Min	Max	Min	Max	
t _{rec}	recovery time	MR to CP0 and MR to $\overline{CP1}$; see Fig. 9								
		V _{CC} = 4.5 V	5	-5	-	5	-	5	-	ns
f _{max}	maximum frequency	CP0 or $\overline{CP1}$; see Fig. 9								
		V _{CC} = 4.5 V	30	61	-	24	-	20	-	MHz
		V _{CC} = 5.0 V; C _L = 15 pF	-	67	-	-	-	-	-	MHz
C _{PD}	power dissipation capacitance	V _I = GND to V _{CC} - 1.5 V; V _{CC} = 5 V; f _i = 1 MHz [3]	-	36	-	-	-	-	-	pF

- [1] t_{pd} is the same as t_{PHL} and t_{PLH}.
- [2] t_i is the same as t_{THL} and t_{TLH}.
- [3] C_{PD} is used to determine the dynamic power dissipation (P_D in μW):
 $P_D = C_{PD} \times V_{CC}^2 \times f_i \times N + \sum(C_L \times V_{CC}^2 \times f_o)$ where:
 f_i = input frequency in MHz;
 f_o = output frequency in MHz;
 C_L = output load capacitance in pF;
 V_{CC} = supply voltage in V;
 N = number of inputs switching;
 $\sum(C_L \times V_{CC}^2 \times f_o)$ = sum of outputs.

10.1. Waveforms and test circuit

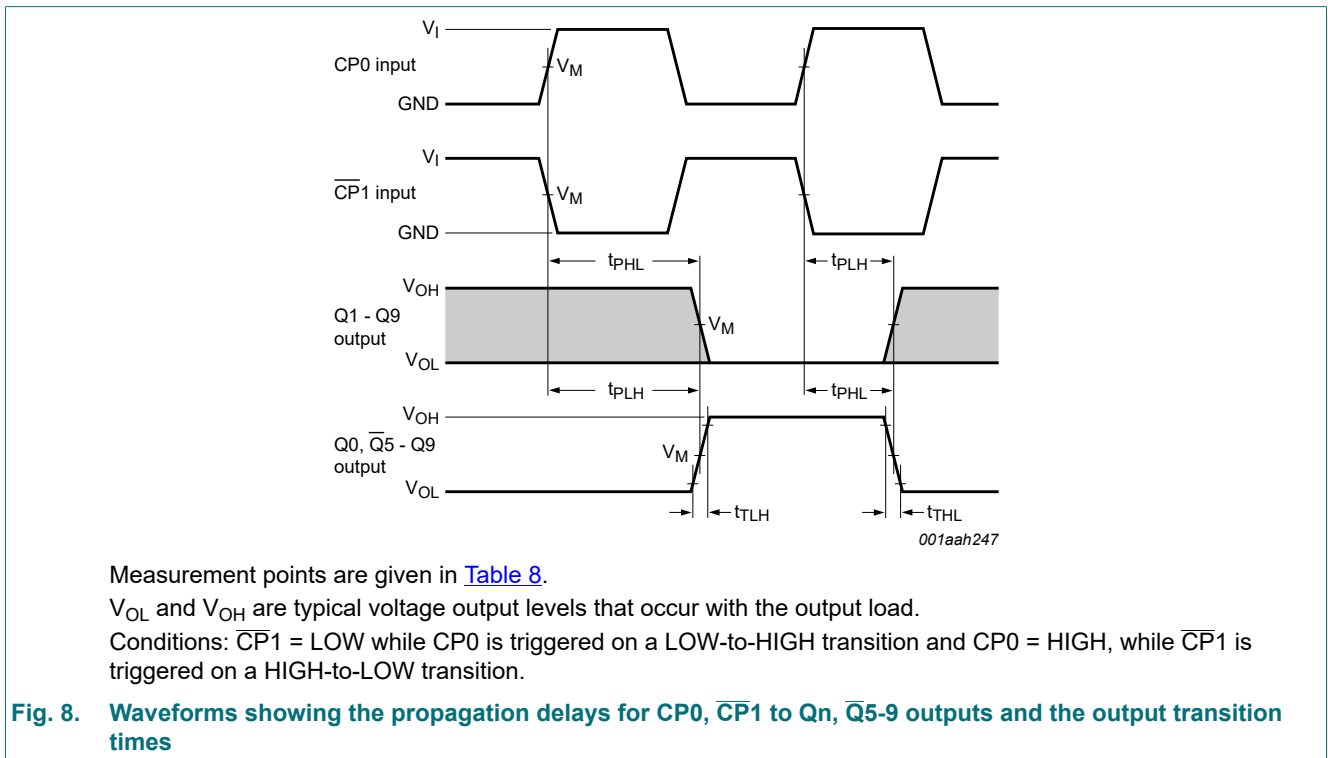

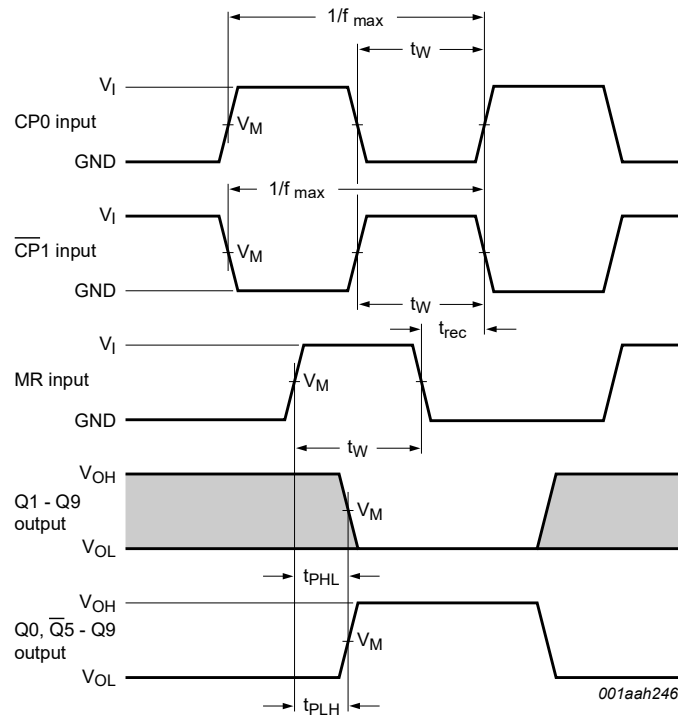

Measurement points are given in [Table 8](#).

V_{OL} and V_{OH} are typical voltage output levels that occur with the output load.

Fig. 9. Waveforms showing the minimum pulse width for CP0, CP1 and MR input; the maximum frequency for CP0 and CP1 input; the recovery time for MR and the MR input to Qn and Q5-9 output propagation delays

Table 8. Measurement points

Type	Input	Output
	V_M	V_M
74HC4017-Q100	$0.5 \times V_{CC}$	$0.5 \times V_{CC}$
74HCT4017-Q100	1.3 V	1.3 V

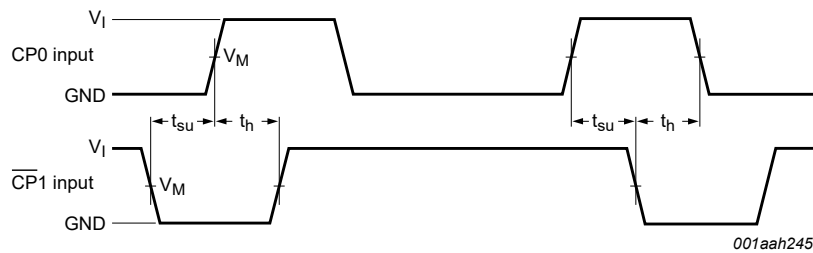

Measurement points are given in [Table 8](#).

V_{OL} and V_{OH} are typical voltage output levels that occur with the output load.

Fig. 10. Waveforms showing the set-up and hold times for CP0 to CP1 and CP1 to CP0

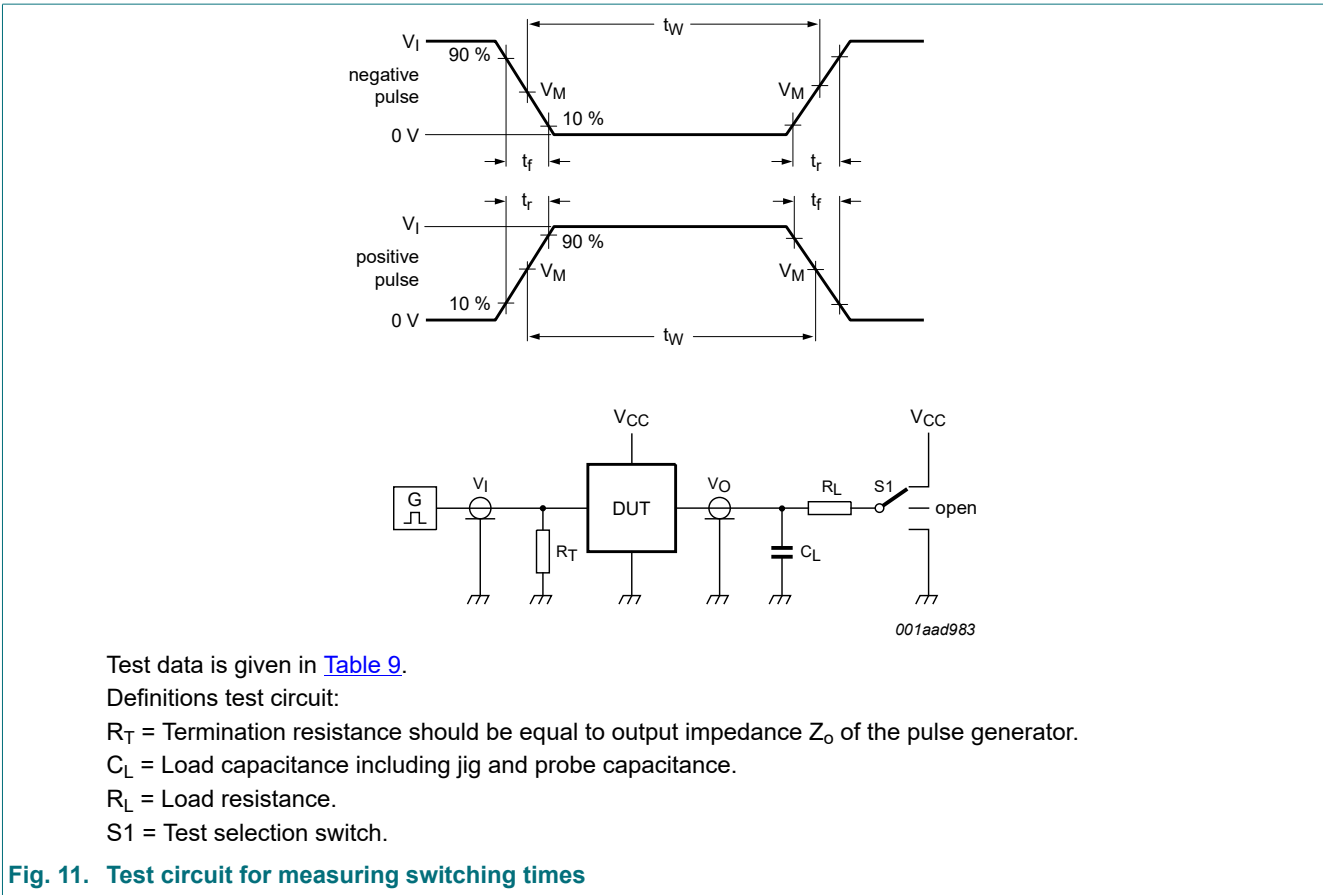

Fig. 11. Test circuit for measuring switching times

Table 9. Test data

Type	Input		Load		S1 position		
	V_I	t_r, t_f	C_L	R_L	t_{PHL}, t_{PLH}	t_{PZH}, t_{PHZ}	t_{PZL}, t_{PLZ}
74HC4017-Q100	V_{CC}	6 ns	15 pF, 50 pF	1 kΩ	open	GND	V_{CC}
74HCT4017-Q100	3 V	6 ns	15 pF, 50 pF	1 kΩ	open	GND	V_{CC}

11. Application information

Some examples of applications for the 74HC4017-Q100; 74HCT4017-Q100 are:

- Decade counter with decimal decoding
- 1 out of n decoding counter (when cascaded)
- Sequential controller
- Timer

Fig. 12 shows a technique for extending the number of decoded output states for the 74HC4017-Q100; 74HCT4017-Q100. Decoded outputs are sequential within each stage and from stage to stage, with no dead time (except propagation delay).

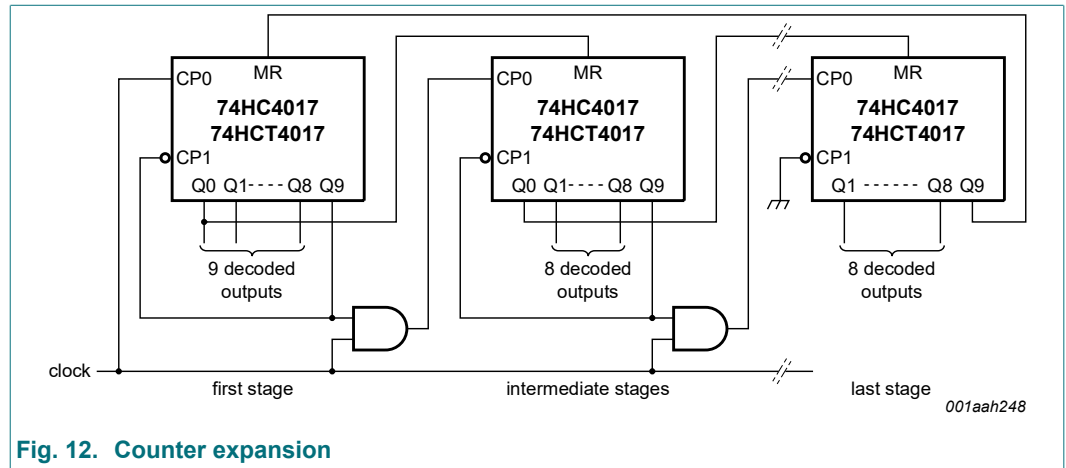

Fig. 12. Counter expansion

Remark: It is essential not to enable the counter on $\overline{CP1}$ when $CP0$ is HIGH, or on $CP0$ when $\overline{CP1}$ is LOW, as this would cause an extra count.

Fig. 13 shows an example of a divide-by 2 through divide-by 10 circuit using one 74HC4017-Q100; 74HCT4017-Q100. Since the 74HC4017-Q100; 74HCT4017-Q100 has an asynchronous reset, the output pulse widths are narrow (minimum expected pulse width is 6 ns). The output pulse widths can be enlarged by inserting an RC network at the MR input.

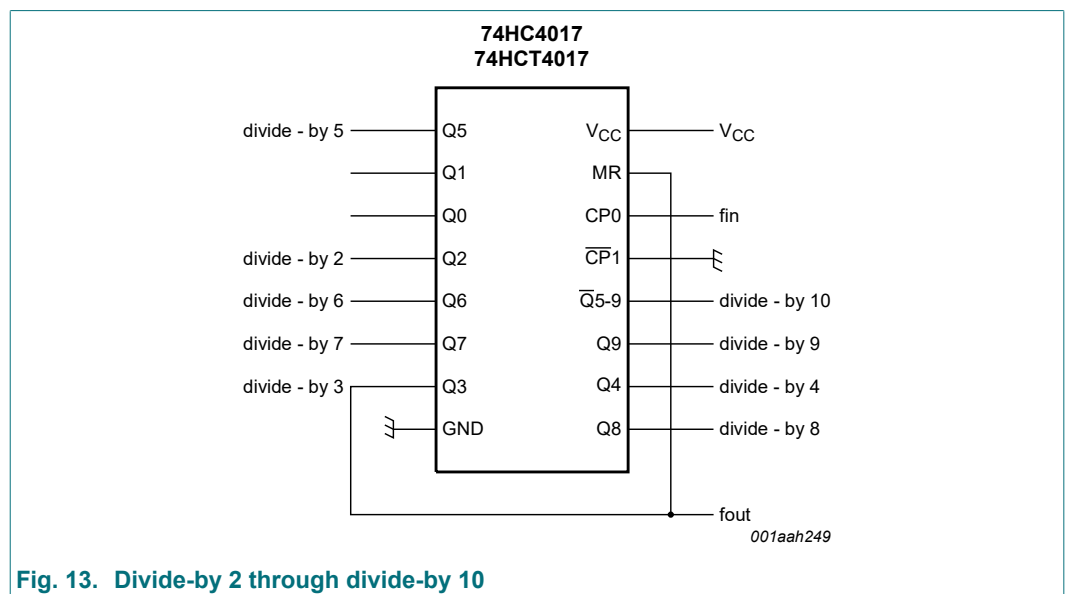

Fig. 13. Divide-by 2 through divide-by 10

12. Package outline

SO16: plastic small outline package; 16 leads; body width 3.9 mm

SOT109-1



Fig. 14. Package outline SOT109-1 (SO16)

TSSOP16: plastic thin shrink small outline package; 16 leads; body width 4.4 mm

SOT403-1



Fig. 15. Package outline SOT403-1 (TSSOP16)

DHVQFN16: plastic dual in-line compatible thermal enhanced very thin quad flat package; no leads; 16 terminals; body 2.5 x 3.5 x 0.85 mm

SOT763-1

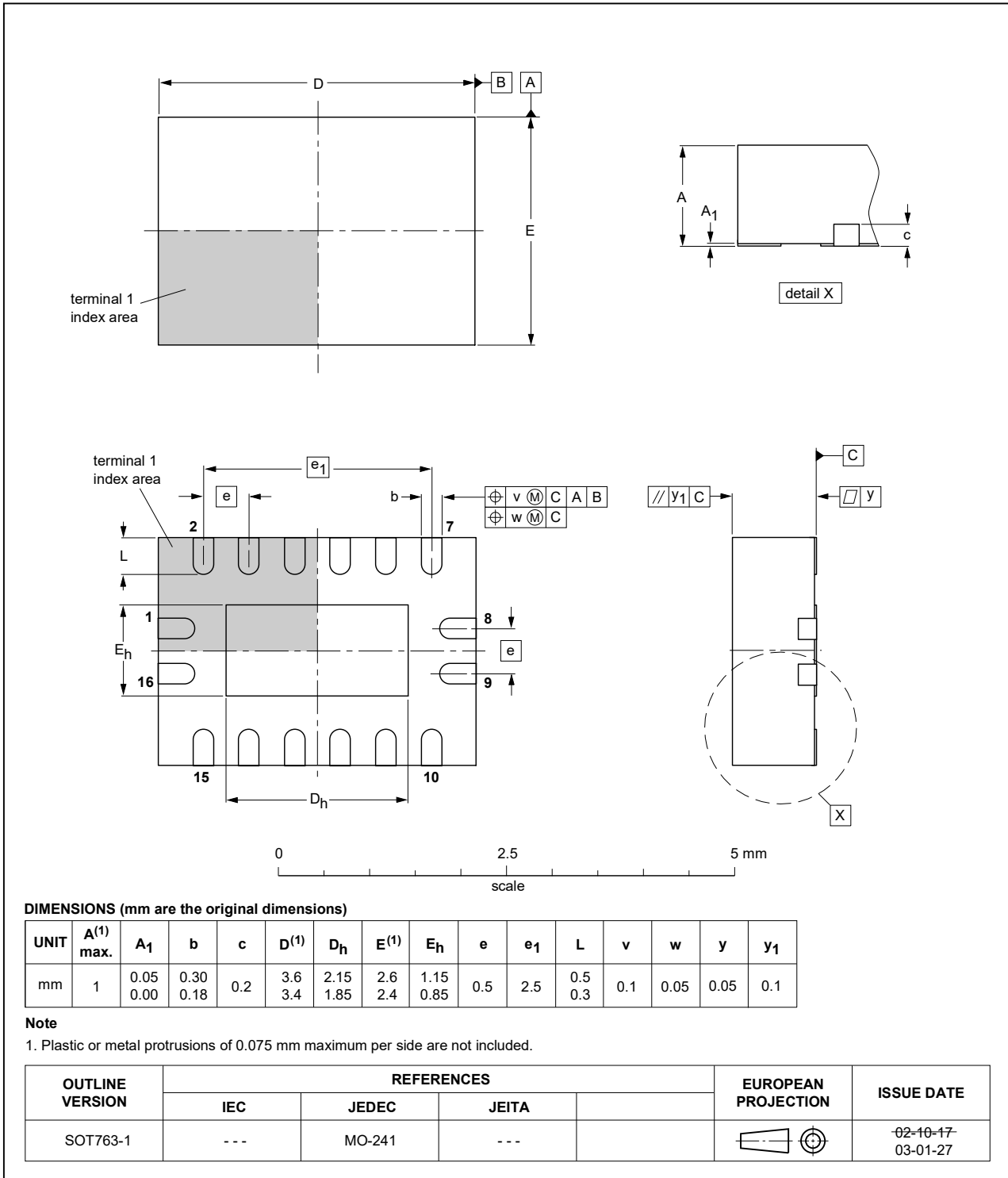

Fig. 16. Package outline SOT763-1 (DHVQFN16)

13. Abbreviations

Table 10. Abbreviations

Acronym	Description
CMOS	Complementary Metal Oxide Semiconductor
DUT	Device Under Test
ESD	ElectroStatic Discharge
HBM	Human Body Model
MIL	Military
MM	Machine Model
TTL	Transistor-Transistor Logic

14. Revision history

Table 11. Revision history

Document ID	Release date	Data sheet status	Change notice	Supersedes
74HC_HCT4017_Q100 v.2	20200701	Product data sheet	-	74HC_HCT4017_Q100 v.1
Modifications:	<ul style="list-style-type: none"> The format of this data sheet has been redesigned to comply with the identity guidelines of Nexperia. Legal texts have been adapted to the new company name where appropriate. Section 1 and Section 2 updated. Table 4: Derating values for P_{tot} total power dissipation have been updated. 			
74HC_HCT4017_Q100 v.1	20140324	Product data sheet	-	-

15. Legal information

Data sheet status

Document status [1][2]	Product status [3]	Definition
Objective [short] data sheet	Development	This document contains data from the objective specification for product development.
Preliminary [short] data sheet	Qualification	This document contains data from the preliminary specification.
Product [short] data sheet	Production	This document contains the product specification.

- [1] Please consult the most recently issued document before initiating or completing a design.
- [2] The term 'short data sheet' is explained in section "Definitions".
- [3] The product status of device(s) described in this document may have changed since this document was published and may differ in case of multiple devices. The latest product status information is available on the internet at <https://www.nexperia.com>.

Definitions

Draft — The document is a draft version only. The content is still under internal review and subject to formal approval, which may result in modifications or additions. Nexperia does not give any representations or warranties as to the accuracy or completeness of information included herein and shall have no liability for the consequences of use of such information.

Short data sheet — A short data sheet is an extract from a full data sheet with the same product type number(s) and title. A short data sheet is intended for quick reference only and should not be relied upon to contain detailed and full information. For detailed and full information see the relevant full data sheet, which is available on request via the local Nexperia sales office. In case of any inconsistency or conflict with the short data sheet, the full data sheet shall prevail.

Product specification — The information and data provided in a Product data sheet shall define the specification of the product as agreed between Nexperia and its customer, unless Nexperia and customer have explicitly agreed otherwise in writing. In no event however, shall an agreement be valid in which the Nexperia product is deemed to offer functions and qualities beyond those described in the Product data sheet.

Disclaimers

Limited warranty and liability — Information in this document is believed to be accurate and reliable. However, Nexperia does not give any representations or warranties, expressed or implied, as to the accuracy or completeness of such information and shall have no liability for the consequences of use of such information. Nexperia takes no responsibility for the content in this document if provided by an information source outside of Nexperia.

In no event shall Nexperia be liable for any indirect, incidental, punitive, special or consequential damages (including - without limitation - lost profits, lost savings, business interruption, costs related to the removal or replacement of any products or rework charges) whether or not such damages are based on tort (including negligence), warranty, breach of contract or any other legal theory.

Notwithstanding any damages that customer might incur for any reason whatsoever, Nexperia's aggregate and cumulative liability towards customer for the products described herein shall be limited in accordance with the Terms and conditions of commercial sale of Nexperia.

Right to make changes — Nexperia reserves the right to make changes to information published in this document, including without limitation specifications and product descriptions, at any time and without notice. This document supersedes and replaces all information supplied prior to the publication hereof.

Suitability for use in automotive applications — This Nexperia product has been qualified for use in automotive applications. Unless otherwise agreed in writing, the product is not designed, authorized or warranted to be suitable for use in life support, life-critical or safety-critical systems or

equipment, nor in applications where failure or malfunction of an Nexperia product can reasonably be expected to result in personal injury, death or severe property or environmental damage. Nexperia and its suppliers accept no liability for inclusion and/or use of Nexperia products in such equipment or applications and therefore such inclusion and/or use is at the customer's own risk.

Quick reference data — The Quick reference data is an extract of the product data given in the Limiting values and Characteristics sections of this document, and as such is not complete, exhaustive or legally binding.

Applications — Applications that are described herein for any of these products are for illustrative purposes only. Nexperia makes no representation or warranty that such applications will be suitable for the specified use without further testing or modification.

Customers are responsible for the design and operation of their applications and products using Nexperia products, and Nexperia accepts no liability for any assistance with applications or customer product design. It is customer's sole responsibility to determine whether the Nexperia product is suitable and fit for the customer's applications and products planned, as well as for the planned application and use of customer's third party customer(s). Customers should provide appropriate design and operating safeguards to minimize the risks associated with their applications and products.

Nexperia does not accept any liability related to any default, damage, costs or problem which is based on any weakness or default in the customer's applications or products, or the application or use by customer's third party customer(s). Customer is responsible for doing all necessary testing for the customer's applications and products using Nexperia products in order to avoid a default of the applications and the products or of the application or use by customer's third party customer(s). Nexperia does not accept any liability in this respect.

Limiting values — Stress above one or more limiting values (as defined in the Absolute Maximum Ratings System of IEC 60134) will cause permanent damage to the device. Limiting values are stress ratings only and (proper) operation of the device at these or any other conditions above those given in the Recommended operating conditions section (if present) or the Characteristics sections of this document is not warranted. Constant or repeated exposure to limiting values will permanently and irreversibly affect the quality and reliability of the device.

Terms and conditions of commercial sale — Nexperia products are sold subject to the general terms and conditions of commercial sale, as published at <http://www.nexperia.com/profile/terms>, unless otherwise agreed in a valid written individual agreement. In case an individual agreement is concluded only the terms and conditions of the respective agreement shall apply. Nexperia hereby expressly objects to applying the customer's general terms and conditions with regard to the purchase of Nexperia products by customer.

No offer to sell or license — Nothing in this document may be interpreted or construed as an offer to sell products that is open for acceptance or the grant, conveyance or implication of any license under any copyrights, patents or other industrial or intellectual property rights.

Export control — This document as well as the item(s) described herein may be subject to export control regulations. Export might require a prior authorization from competent authorities.

Translations — A non-English (translated) version of a document is for reference only. The English version shall prevail in case of any discrepancy between the translated and English versions.

Trademarks

Notice: All referenced brands, product names, service names and trademarks are the property of their respective owners.

Contents

1. General description	1
2. Features and benefits	1
3. Ordering information	2
4. Functional diagram	2
5. Pinning information	5
5.1. Pinning.....	5
5.2. Pin description.....	5
6. Functional description	6
7. Limiting values	6
8. Recommended operating conditions	6
9. Static characteristics	7
10. Dynamic characteristics	9
10.1. Waveforms and test circuit.....	11
11. Application information	14
12. Package outline	15
13. Abbreviations	18
14. Revision history	18
15. Legal information	19

© Nexperia B.V. 2020. All rights reserved

For more information, please visit: <http://www.nexperia.com>

For sales office addresses, please send an email to: salesaddresses@nexperia.com

Date of release: 1 July 2020

Данный компонент на территории Российской Федерации

Вы можете приобрести в компании MosChip.

Для оперативного оформления запроса Вам необходимо перейти по данной ссылке:

<http://moschip.ru/get-element>

Вы можете разместить у нас заказ для любого Вашего проекта, будь то серийное производство или разработка единичного прибора.

В нашем ассортименте представлены ведущие мировые производители активных и пассивных электронных компонентов.

Нашей специализацией является поставка электронной компонентной базы двойного назначения, продукции таких производителей как XILINX, Intel (ex.ALTERA), Vicor, Microchip, Texas Instruments, Analog Devices, Mini-Circuits, Amphenol, Glenair.

Сотрудничество с глобальными дистрибьюторами электронных компонентов, предоставляет возможность заказывать и получать с международных складов практически любой перечень компонентов в оптимальные для Вас сроки.

На всех этапах разработки и производства наши партнеры могут получить квалифицированную поддержку опытных инженеров.

Система менеджмента качества компании отвечает требованиям в соответствии с ГОСТ Р ИСО 9001, ГОСТ РВ 0015-002 и ЭС РД 009

Офис по работе с юридическими лицами:

105318, г.Москва, ул.Щербаковская д.3, офис 1107, 1118, ДЦ «Щербаковский»

Телефон: +7 495 668-12-70 (многоканальный)

Факс: +7 495 668-12-70 (доб.304)

E-mail: info@moschip.ru

Skype отдела продаж:

moschip.ru

moschip.ru_4

moschip.ru_6

moschip.ru_9