

RF Power LDMOS transistor HF up to 1.5 GHz

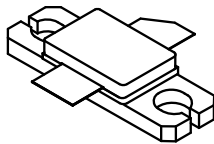

M243
Epoxy sealed

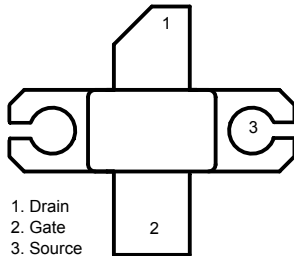

GADG310120180952IG

Features

- Excellent thermal stability
- Common source configuration
- P_{OUT} (@28 V) = 45 W with 18.5 dB gain @945 MHz
- BeO free package
- In compliance with European Directive 2002/95/EC

Description

The ST9045C is a common source N-channel enhancement-mode lateral field-effect RF power transistor designed for broadband commercial and industrial applications at frequencies up to 1.5 GHz. The ST9045C is designed for high gain and broadband performance operating in common source mode at 28 V. It is ideal for base station applications requiring high linearity.

Product status link

[ST9045C](#)

Product summary

Order code	ST9045C
Package	M243
Branding	ST9045C

1 Maximum ratings

($T_{CASE} = 25\text{ °C}$)

Table 1. Absolute maximum ratings

Symbol	Parameter	Value	Unit
$V_{(BR)DSS}$	Drain-source voltage	90	V
V_{GS}	Gate-source voltage	-10 +13	V
I_D	Drain current	9	A
P_{DISS}	Power dissipation (@ $T_C = 70\text{ °C}$)	130	W
T_J	Maximum operating junction temperature	200	°C
T_{STG}	Storage temperature	-65 to +150	°C

Table 2. Thermal data

Symbol	Parameter	Value	Unit
R_{thJC}	Junction-case thermal resistance	1.0	°C/W

2 Electrical characteristics

($T_{CASE} = 25\text{ °C}$)

Table 3. Static

Symbol	Test conditions	Min.	Typ.	Max.	Unit
$V_{(BR)DSS}$	$V_{GS} = 0\text{ V}, I_{DS} = 10\text{ mA}$	90	100		V
I_{DSS}	$V_{GS} = 0\text{ V}, V_{DS} = 28\text{ V}$			1	μA
I_{GSS}	$V_{GS} = 12\text{ V}, V_{DS} = 0\text{ V}$			1	μA
$V_{GS(Q)}$	$V_{DS} = 28\text{ V}, I_{DS} = 300\text{ mA}$	2	3	5	V
$V_{DS(ON)}$	$V_{GS} = 10\text{ V}, I_{DS} = 3\text{ A}$		1	1.3	V
G_{FS}	$V_{DS} = 10\text{ V}, I_{DS} = 3\text{ A}$		3.3		S
C_{ISS}	$V_{GS} = 0\text{ V}, V_{DS} = 28\text{ V}, f = 1\text{ MHz}$		54		pF
C_{OSS}	$V_{GS} = 0\text{ V}, V_{DS} = 28\text{ V}, f = 1\text{ MHz}$		18		pF
C_{RSS}	$V_{GS} = 0\text{ V}, V_{DS} = 28\text{ V}, f = 1\text{ MHz}$		1.2		pF

Table 4. Dynamic (RF spec @ 945 MHz)

Symbol	Test conditions	Min.	Typ.	Max.	Unit
P_{OUT}	$V_{DD} = 28\text{ V}, I_{DQ} = 300\text{ mA}, P_{IN} = 1\text{ W}$		63	-	W
Gain	$V_{DD} = 28\text{ V}, I_{DQ} = 300\text{ mA}, P_{IN} = 1\text{ W}$		18.5	-	dB
Efficiency	$V_{DD} = 28\text{ V}, I_{DQ} = 300\text{ mA}, P_{IN} = 1\text{ W}$		70	-	%
Load mismatch	$V_{DD} = 28\text{ V}, I_{DQ} = 300\text{ mA}, P_{OUT} = 45\text{ W}$ All phase angles	20:1		-	VSWR

3 Impedance data

Figure 1. Impedance data

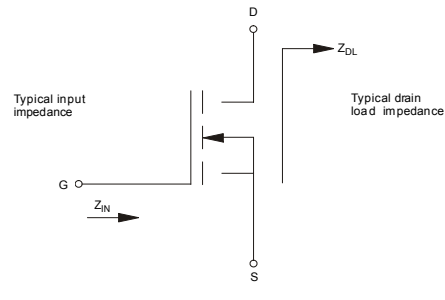

Table 5. Impedance data

Frequency (MHz)	$Z_{IN}\Omega$	$Z_{DL}\Omega$
945	$0.76 + j 0.11$	$5.2 - j 0.87$

4 Typical performance

Figure 2. Power gain and efficiency vs output power and I_{dq} ($V_{DD} = 28\text{ V}$, $f_o = 945\text{ MHz}$)

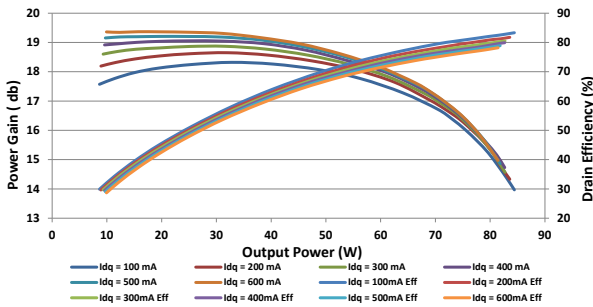

Figure 3. Power gain and efficiency vs output power and V_{DD} ($I_{dq} = 300\text{ mA}$, $f_o = 945\text{ MHz}$ tuned at $V_{DD} = 28\text{ V}$)

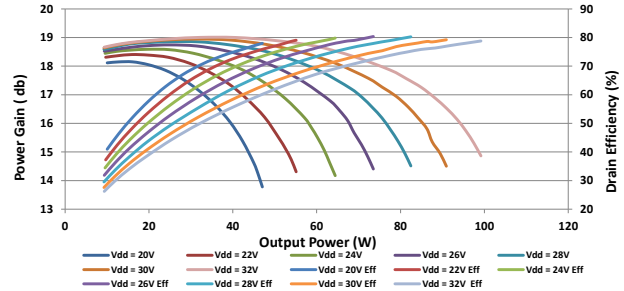

Figure 4. Output power and efficiency vs V_{DD} and input power ($I_{dq} = 300\text{ mA}$, $f_o = 945\text{ MHz}$ tuned at $V_{DD} = 28\text{ V}$)

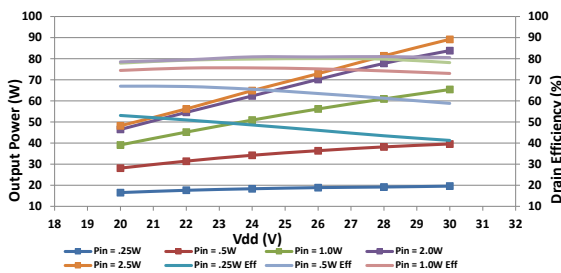

Figure 5. Output power and drain current vs V_{DD} and input power ($I_{dq} = 300\text{ mA}$, $f_o = 945\text{ MHz}$ tuned at $V_{DD} = 28\text{ V}$)

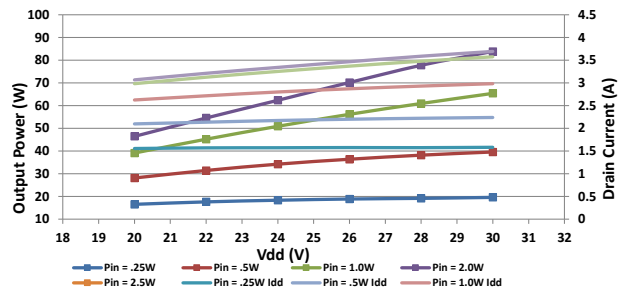

Figure 6. Output power and drain current vs V_{GS} and input power ($V_{DD} = 28\text{ V}$, $f_o = 945\text{ MHz}$)

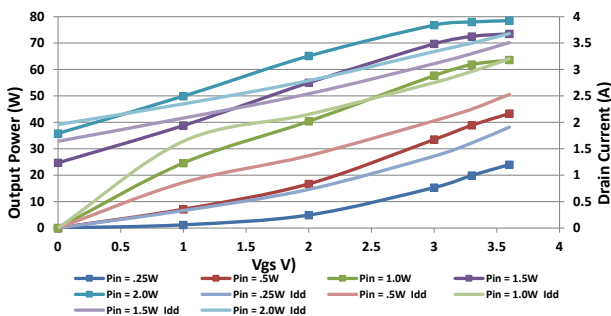

Figure 7. Output power vs V_{GS} and input power ($V_{DD} = 28\text{ V}$, $f_o = 945\text{ MHz}$)

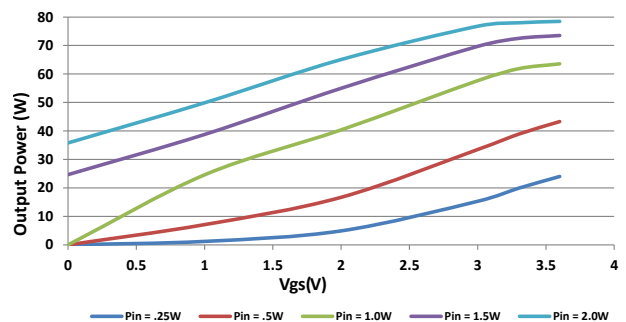

Figure 8. Drain current vs V_{GS} and input power ($V_{DD} = 28$ V, $f_o = 945$ MHz)

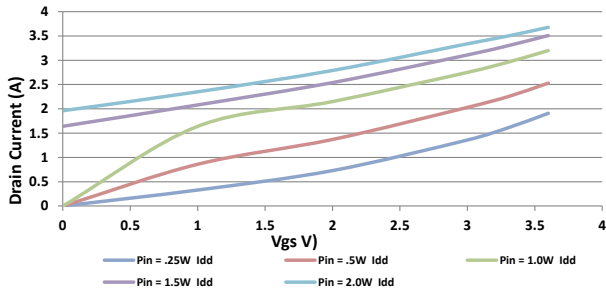
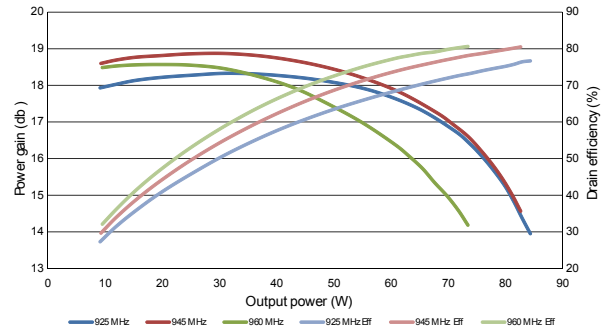
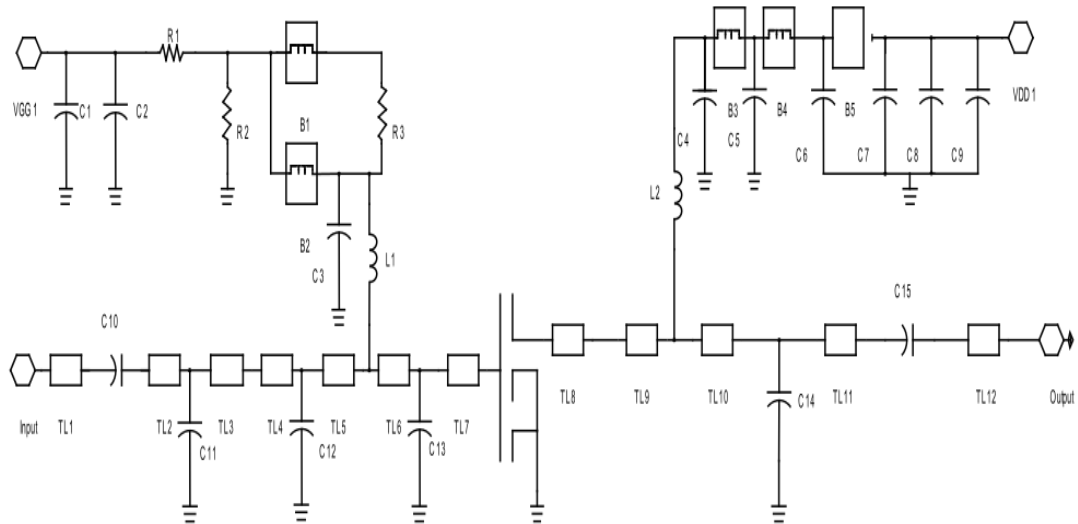

Figure 9. Power gain and efficiency vs frequency ($V_{DD} = 28$ V, $I_{dq} = 300$ mA tuned at 945 MHz)



5 Test circuit

Figure 10. Test circuit

Table 6. ST9045C components list

Item	Quantity	Part number	Vendor	Description
R1, R2	2	CR1206-8W-112JB	VENKEL	1.1 k Ω 1/8 W surface mount chip resistor
R3	1	CR1206-8W-100JB	VENKEL	10 Ω 1/8 W surface mount chip resistor
Coil	2		BELDEN	Inductor 5 turn air wound #20 AWG ID = 0.130 inches (3.3 mm) nylon coated
B1, B2, B3, B4, B5	5	2743021447	Fair-Rite Products	Surface mount EMI shield bead
C1, C7, C8	3	T491D106K035AT	KEMET	10 μ F 35 V tantalum capacitors
C2	1			100 μ F 63 V electrolytic capacitor
C3, C4, C10, C15	4	ATC100B470XXXX	ATC	47 pF chip capacitor
C5, C6	2	ATC200B393MW	ATC	39000 pF chip capacitor
C9	1			330 μ F 50 V electrolytic capacitor
C11, C13, C14	3	27291PC	Johanson Technology	0.8 to 8 pF giga-trim variable capacitor
C12	1	ATC100B4R7XXXX	ATC	4.7 pF chip capacitor
TL1				L = 1.350 inches [34.29 mm] W = 0.082 inches [02.08 mm]
TL2				L = 0.144 inches [3.65 mm] W = 0.082 inches [02.08 mm]
TL3				L = 0.311 inches [7.91 mm] W = 0.082 inches [02.08 mm]
TL4				L = 0.082 inches [2.09 mm] W = 0.323 inches [08.21 mm]

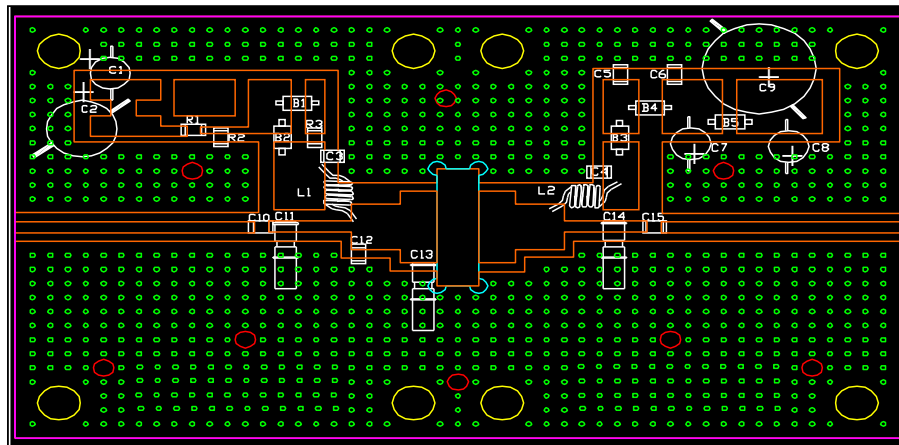
Item	Quantity	Part number	Vendor	Description
TL5				L = 0.194 inches [4.94 mm] W = 0.323 inches [08.21 mm]
TL6				L = 0.059 inches [1.49 mm] W = 0.506 inches [12.85 mm]
TL7				L = 0.144 inches [3.65 mm] W = 0.506 inches [12.85 mm]
TL8				L = 0.208 inches [5.28 mm] W = 0.506 inches [12.85 mm]
TL9				L = 0.275 inches [6.98 mm] W = 0.323 inches [08.21 mm]
TL10				L = 0.210 inches [5.33 mm] W = 0.082 inches [02.08 mm]
TL11				L = 0.260 inches [6.60 mm] W = 0.082 inches [02.08 mm]
TL12				L = 1.350 inches [34.29 mm] W = 0.082 inches [02.08 mm]
Board 3X5	1		ROGERS	Er = 2.55, t = 0.0026 inches, h = 0.030 inches

Figure 11. Circuit layout

6 Package information

In order to meet environmental requirements, ST offers these devices in different grades of ECOPACK® packages, depending on their level of environmental compliance. ECOPACK® specifications, grade definitions and product status are available at: www.st.com. ECOPACK® is an ST trademark.

6.1 M243 (.230 x .360 2L N/HERM W/FLG) package information

Figure 12. M243 (.230 x .360 2L N/HERM W/FLG) package outline

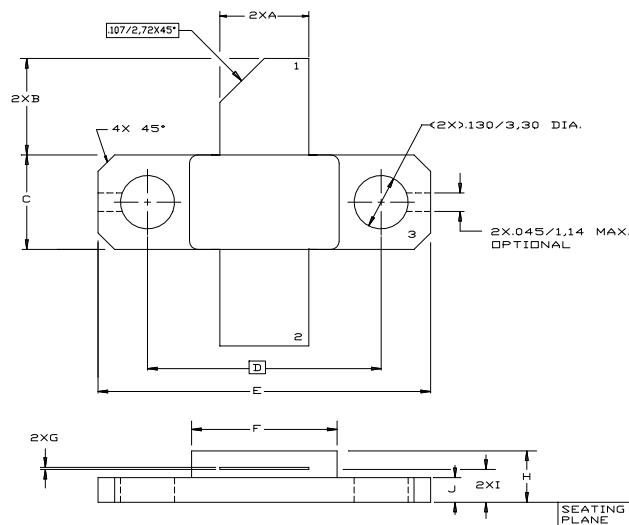

Table 7. M243 (.230 x .360 2L N/HERM W/FLG) package mechanical data

Dim.	mm		
	Min.	Typ.	Max.
A	5.21		5.72
B	5.46		6.48
C	5.59		6.1
D		14.27	
E	20.07		20.57
F	8.89		9.4
G	0.1		0.15
H	3.18		4.45
I	1.83		2.24
J	1.27		1.78

7 Marking, packing and shipping specifications

Table 8. Packing and shipping specifications

Order code	Packing	Pieces per tray	Dry pack humidity	Lot code
ST9045C	Plastic tray	25	< 10%	Two codes max.

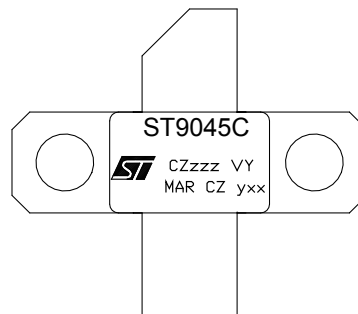
Figure 13. Marking layout

Table 9. Marking specifications

Symbol	Description
CZ	Assembly plant
zzz	Last 3 digits of diffusion lot
VY	Diffusion plant
MAR	Country of origin
CZ	Test and finishing plant
y	Assembly year
xx	Assembly week

Revision history

Table 10. Document revision history

Date	Revision	Changes
03-Mar-2016	1	Initial release.
24-Jan-2018	2	Updated title and description on cover page. Updated <i>Section 2: "Electrical characteristics"</i> . Updated <i>Section 4: "Typical performance"</i> . Minor text changes
16-Mar-2018	3	Updated package silhouette and pin connection in cover page.

Contents

1	Maximum ratings	2
2	Electrical characteristics	3
3	Impedance data	4
4	Typical performance	5
5	Test circuit	7
6	Package information	9
6.1	M243 (.230 x .360 2L N/HERM W/FLG) package information	9
7	Marking, packing and shipping specifications	10
	Revision history	11

IMPORTANT NOTICE – PLEASE READ CAREFULLY

STMicroelectronics NV and its subsidiaries (“ST”) reserve the right to make changes, corrections, enhancements, modifications, and improvements to ST products and/or to this document at any time without notice. Purchasers should obtain the latest relevant information on ST products before placing orders. ST products are sold pursuant to ST’s terms and conditions of sale in place at the time of order acknowledgement.

Purchasers are solely responsible for the choice, selection, and use of ST products and ST assumes no liability for application assistance or the design of Purchasers’ products.

No license, express or implied, to any intellectual property right is granted by ST herein.

Resale of ST products with provisions different from the information set forth herein shall void any warranty granted by ST for such product.

ST and the ST logo are trademarks of ST. All other product or service names are the property of their respective owners.

Information in this document supersedes and replaces information previously supplied in any prior versions of this document.

© 2018 STMicroelectronics – All rights reserved

Данный компонент на территории Российской Федерации

Вы можете приобрести в компании MosChip.

Для оперативного оформления запроса Вам необходимо перейти по данной ссылке:

<http://moschip.ru/get-element>

Вы можете разместить у нас заказ для любого Вашего проекта, будь то серийное производство или разработка единичного прибора.

В нашем ассортименте представлены ведущие мировые производители активных и пассивных электронных компонентов.

Нашей специализацией является поставка электронной компонентной базы двойного назначения, продукции таких производителей как XILINX, Intel (ex.ALTERA), Vicor, Microchip, Texas Instruments, Analog Devices, Mini-Circuits, Amphenol, Glenair.

Сотрудничество с глобальными дистрибьюторами электронных компонентов, предоставляет возможность заказывать и получать с международных складов практически любой перечень компонентов в оптимальные для Вас сроки.

На всех этапах разработки и производства наши партнеры могут получить квалифицированную поддержку опытных инженеров.

Система менеджмента качества компании отвечает требованиям в соответствии с ГОСТ Р ИСО 9001, ГОСТ РВ 0015-002 и ЭС РД 009

Офис по работе с юридическими лицами:

105318, г.Москва, ул.Щербаковская д.3, офис 1107, 1118, ДЦ «Щербаковский»

Телефон: +7 495 668-12-70 (многоканальный)

Факс: +7 495 668-12-70 (доб.304)

E-mail: info@moschip.ru

Skype отдела продаж:

moschip.ru

moschip.ru_4

moschip.ru_6

moschip.ru_9