

Common Source

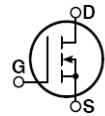

# RF POWER MOSFETS

## N-CHANNEL ENHANCEMENT MODE

**300V 150W 60MHz**

The ARF465A and 465B comprise a symmetric pair of common source RF power transistors designed for push-pull scientific, commercial, medical and industrial RF power amplifier applications up to 60 MHz.

• **Specified 300 Volt, 40.68 MHz Characteristics:**

**Output Power = 150 Watts.**

**Gain = 13dB (Class C)**

**Efficiency = 75%**

• **Low Cost Common Source RF Package.**

• **Low  $V_{th}$  thermal coefficient.**

• **Low Thermal Resistance.**

• **Optimized SOA for Superior Ruggedness.**

### MAXIMUM RATINGS

 All Ratings:  $T_C = 25^\circ\text{C}$  unless otherwise specified.

Symbol	Parameter	ARF465A/B(G)	UNIT
$V_{DSS}$	Drain-Source Voltage	1200	Volts
$V_{DGO}$	Drain-Gate Voltage	1200	
$I_D$	Continuous Drain Current @ $T_C = 25^\circ\text{C}$	6	Amps
$V_{GS}$	Gate-Source Voltage	$\pm 30$	Volts
$P_D$	Total Power Dissipation @ $T_C = 25^\circ\text{C}$	250	Watts
$R_{\theta JC}$	Junction to Case	0.50	$^\circ\text{C}/\text{W}$
$T_J, T_{STG}$	Operating and Storage Junction Temperature Range	-55 to 150	$^\circ\text{C}$
$T_L$	Lead Temperature: 0.063" from Case for 10 Sec.	300	

### STATIC ELECTRICAL CHARACTERISTICS

Symbol	Characteristic / Test Conditions	MIN	TYP	MAX	UNIT
$BV_{DSS}$	Drain-Source Breakdown Voltage ( $V_{GS} = 0\text{V}, I_D = 250 \mu\text{A}$ )	1200			Volts
$V_{DS(ON)}$	On State Drain Voltage <sup>①</sup> ( $I_D(ON) = 3\text{A}, V_{GS} = 10\text{V}$ )			8	
$I_{DSS}$	Zero Gate Voltage Drain Current ( $V_{DS} = V_{DSS}, V_{GS} = 0\text{V}$ )			25	$\mu\text{A}$
	Zero Gate Voltage Drain Current ( $V_{DS} = 0.8 V_{DSS}, V_{GS} = 0\text{V}, T_C = 125^\circ\text{C}$ )			250	
$I_{GSS}$	Gate-Source Leakage Current ( $V_{GS} = \pm 30\text{V}, V_{DS} = 0\text{V}$ )			$\pm 100$	nA
$g_{fs}$	Forward Transconductance ( $V_{DS} = 25\text{V}, I_D = 3\text{A}$ )	3	4		mhos
$V_{GS(TH)}$	Gate Threshold Voltage ( $V_{DS} = V_{GS}, I_D = 50\text{mA}$ )	3		5	Volts

 **CAUTION:** These Devices are Sensitive to Electrostatic Discharge. Proper Handling Procedures Should Be Followed.

## DYNAMIC CHARACTERISTICS

ARF465A/B(G)

Symbol	Characteristic	Test Conditions	MIN	TYP	MAX	UNIT
$C_{iss}$	Input Capacitance	$V_{GS} = 0V$ $V_{DS} = 200V$ $f = 1\text{ MHz}$		1200	1500	pF
$C_{oss}$	Output Capacitance			80	100	
$C_{rss}$	Reverse Transfer Capacitance			30	50	
$t_{d(on)}$	Turn-on Delay Time	$V_{GS} = 15V$ $V_{DD} = 0.5V$ $I_D = I_{D[Cont.]} @ 25^\circ C$ $R_G = 1.6W$		7	15	ns
$t_r$	Rise Time			5	10	
$t_{d(off)}$	Turn-off Delay Time			21	34	
$t_f$	Fall Time			12	25	

## FUNCTIONAL CHARACTERISTICS

Symbol	Characteristic	Test Conditions	MIN	TYP	MAX	UNIT
$G_{PS}$	Common Source Amplifier Power Gain	$f = 40.68\text{ MHz}$	13	15		dB
$\eta$	Drain Efficiency	$V_{GS} = 0V$ $V_{DD} = 300V$	70	75		%
$\Psi$	Electrical Ruggedness VSWR 6:1	$P_{out} = 150W$	No Degradation in Output Power			

① Pulse Test: Pulse width < 380  $\mu S$ , Duty Cycle < 2%

Microsemi Reserves the right to change, without notice, the specifications and information contained herein.

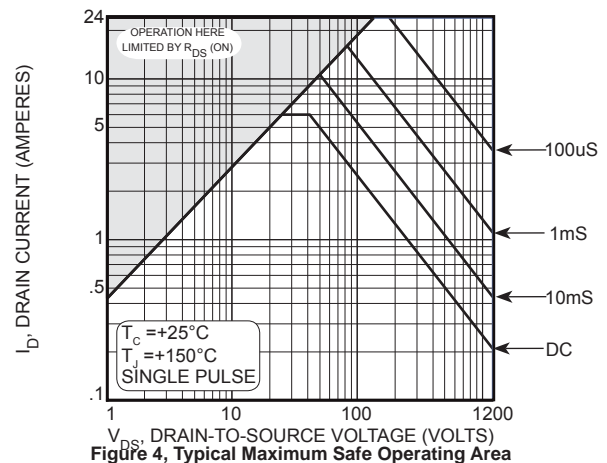
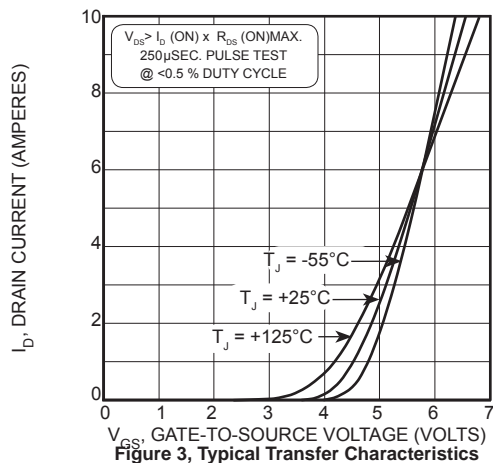
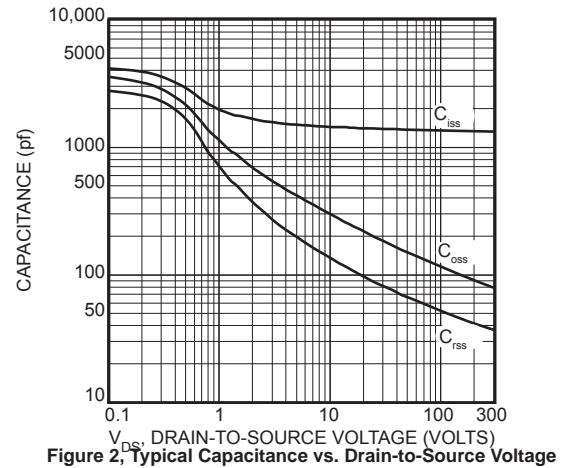
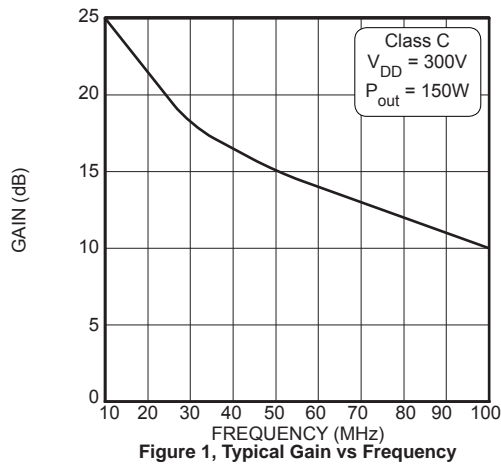

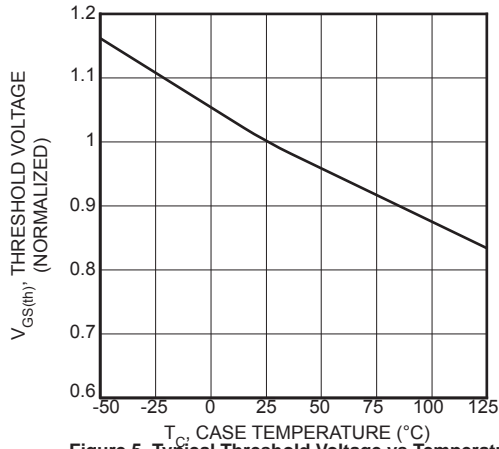

Figure 5, Typical Threshold Voltage vs Temperature

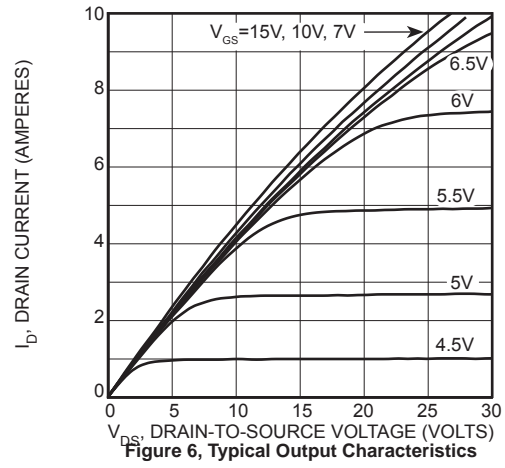

Figure 6, Typical Output Characteristics

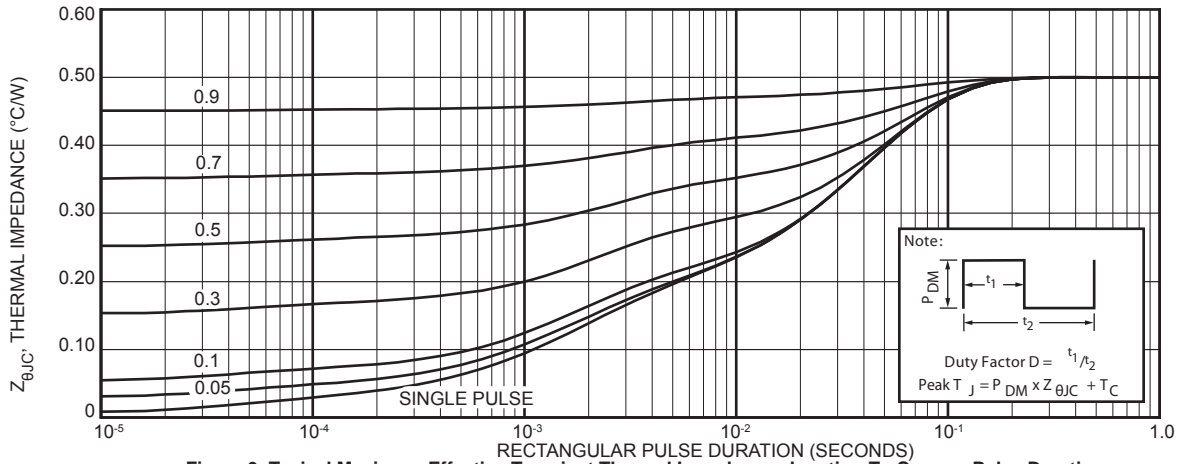

Figure 9, Typical Maximum Effective Transient Thermal Impedance, Junction-To-Case vs Pulse Duration

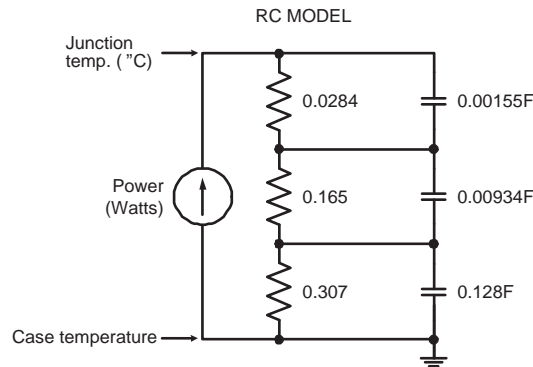

Figure 9a, TRANSIENT THERMAL IMPEDANCE MODEL

Table 1 - Typical Class AB Large Signal input - Output Impedance

Freq. (MHz)	Z <sub>in</sub> (Ω)	Z <sub>OL</sub> (Ω)
2.0	21.4 - j 8.7	206 - j 45
13.5	2.6 - j 7.3	68 - j 99
27	.54 - j 2.9	22 - j 64
40	.22 - j .69	10.5 - j 44
65	.31 + j 1.65	4.4 - j 27

Z<sub>in</sub> - Gate shunted with 25Ω

I<sub>DQ</sub> = 100mA

Z<sub>OL</sub> - Conjugate of optimum load for 150 Watts output at V<sub>dd</sub> = 300V

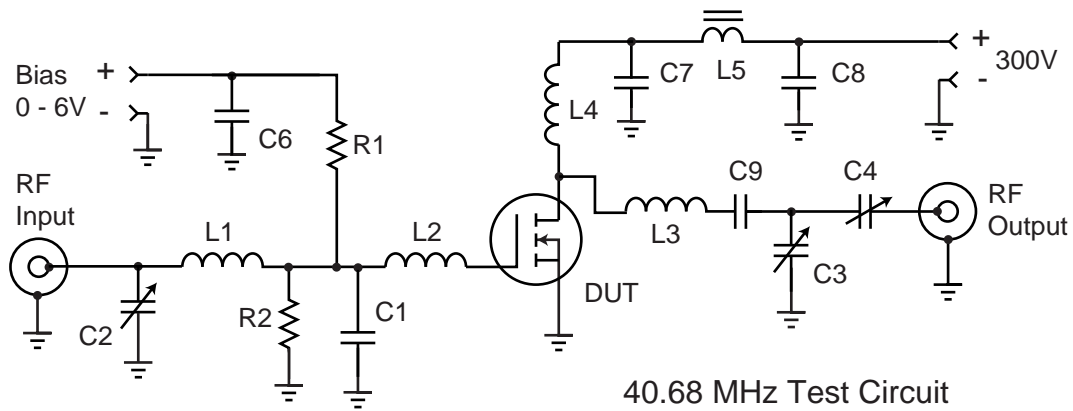

- C1 - 1000pF 100V chip ATC 700B
- C2-C5 - Arco 463 Mica trimmer
- C6-C8 - .01  $\mu$ F 500V ceramic chip
- C9 - 2200 pF COG 500 V chip
- L1 - 4t #20 AWG .25"ID .3"L ~110 nH
- L2 - 2t #20 AWG .25"ID .3"L ~ 25 nH

- L3-- 4t #16 AWG .4" ID .5"L ~290 nH
- L4 -- 25t #24 AWG .35"ID ~2uH
- L5-- VK200-4B ferrite choke 3uH
- R1-R2 -- 51 Ohm 0.5W Carbon
- DUT = ARF465A/B

**TO-247 Package Outline**

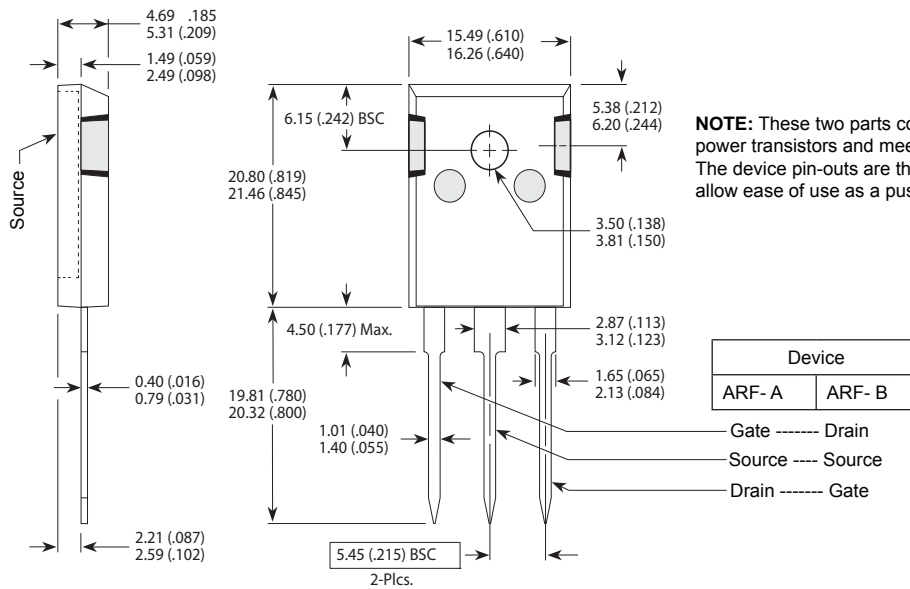

**NOTE:** These two parts comprise a symmetric pair of RF power transistors and meet the same electrical specifications. The device pin-outs are the mirror image of each other to allow ease of use as a push-pull pair.

**HAZARDOUS MATERIAL WARNING:**

The ceramic portion of the device between leads and mounting flange is beryllium oxide. Beryllium oxide dust is highly toxic when inhaled. Care must be taken during handling and mounting to avoid damage to this area. These devices must never be thrown away with general industrial or domestic waste.

**Disclaimer:**

The information contained in the document (unless it is publicly available on the Web without access restrictions) is PROPRIETARY AND CONFIDENTIAL information of Microsemi and cannot be copied, published, uploaded, posted, transmitted, distributed or disclosed or used without the express duly signed written consent of Microsemi. If the recipient of this document has entered into a disclosure agreement with Microsemi, then the terms of such Agreement will also apply. This document and the information contained herein may not be modified, by any person other than authorized personnel of Microsemi. No license under any patent, copyright, trade secret or other intellectual property right is granted to or conferred upon you by disclosure or delivery of the information, either expressly, by implication, inducement, estoppels or otherwise. Any license under such intellectual property rights must be approved by Microsemi in writing signed by an officer of Microsemi.

Microsemi reserves the right to change the configuration, functionality and performance of its products at anytime without any notice. This product has been subject to limited testing and should not be used in conjunction with life-support or other mission-critical equipment or applications. Microsemi assumes no liability whatsoever, and Microsemi disclaims any express or implied warranty, relating to sale and/or use of Microsemi products including liability or warranties relating to fitness for a particular purpose, merchantability, or infringement of any patent, copyright or other intellectual property right. Any performance specifications believed to be reliable but are not verified and customer or user must conduct and complete all performance and other testing of this product as well as any user or customers final application. User or customer shall not rely on any data and performance specifications or parameters provided by Microsemi. It is the customer's and user's responsibility to independently determine suitability of any Microsemi product and to test and verify the same. The information contained herein is provided "AS IS, WHERE IS" and with all faults, and the entire risk associated with such information is entirely with the User. Microsemi specifically disclaims any liability of any kind including for consequential, incidental and punitive damages as well as lost profit. The product is subject to other terms and conditions which can be located on the web at <http://www.microsemi.com/legal/tnc.asp>

## Данный компонент на территории Российской Федерации

### Вы можете приобрести в компании MosChip.

Для оперативного оформления запроса Вам необходимо перейти по данной ссылке:

<http://moschip.ru/get-element>

Вы можете разместить у нас заказ для любого Вашего проекта, будь то серийное производство или разработка единичного прибора.

В нашем ассортименте представлены ведущие мировые производители активных и пассивных электронных компонентов.

Нашей специализацией является поставка электронной компонентной базы двойного назначения, продукции таких производителей как XILINX, Intel (ex.ALTERA), Vicor, Microchip, Texas Instruments, Analog Devices, Mini-Circuits, Amphenol, Glenair.

Сотрудничество с глобальными дистрибьюторами электронных компонентов, предоставляет возможность заказывать и получать с международных складов практически любой перечень компонентов в оптимальные для Вас сроки.

На всех этапах разработки и производства наши партнеры могут получить квалифицированную поддержку опытных инженеров.

Система менеджмента качества компании отвечает требованиям в соответствии с ГОСТ Р ИСО 9001, ГОСТ РВ 0015-002 и ЭС РД 009

### Офис по работе с юридическими лицами:

105318, г.Москва, ул.Щербаковская д.3, офис 1107, 1118, ДЦ «Щербаковский»

Телефон: +7 495 668-12-70 (многоканальный)

Факс: +7 495 668-12-70 (доб.304)

E-mail: [info@moschip.ru](mailto:info@moschip.ru)

Skype отдела продаж:

moschip.ru

moschip.ru\_4

moschip.ru\_6

moschip.ru\_9