

Description

The AP3776B is a high performance AC/DC power supply controller for battery charger and adapter applications. It can meet less than 10mW standby power for “Super Star” charger criteria. The device uses Pulse Frequency Modulation (PFM) method to build discontinuous conduction mode (DCM) flyback power supplies.

The AP3776B provides accurate constant voltage (CV), constant current (CC) and outstanding dynamic performance without requiring an opto-coupler. It also eliminates the need of loop compensation circuitry while maintaining stability.

The AP3776B achieves excellent regulation and high average efficiency, less than 10mW no-load power consumption and less than 1s startup time. When AP3776B is used with AP4341, APR343 or APR3415, good under-shoot performance and higher conversion efficiency can be achieved.

The AP3776B is available in SO-8 package.

Features

- Primary Side Control for Eliminating Opto-coupler
- 10mW No-load Input Power
- Compensation for External Component Temperature Variations
- Flyback Topology in DCM Operation
- Random Frequency Adjustment to Reduce System EMI
- Semi-valley Turn on for the Higher Efficiency
- Built-in Soft Start
- Over Voltage Protection
- Over Temperature Protection
- Short Circuit Protection
- AP4341, APR343 or APR3415 Awakening Signal Detection
- Audio Noise Reduction
- Internal Cable Compensation
- SO-8 Package
- **Totally Lead-Free & Fully RoHS Compliant (Notes 1 & 2)**
- **Halogen and Antimony Free. “Green” Device (Note 3)**

- Notes:
1. No purposely added lead. Fully EU Directive 2002/95/EC (RoHS) & 2011/65/EU (RoHS 2) compliant.
 2. See http://www.diodes.com/quality/lead_free.html for more information about Diodes Incorporated’s definitions of Halogen- and Antimony-free, “Green” and Lead-free.
 3. Halogen- and Antimony-free “Green” products are defined as those which contain <900ppm bromine, <900ppm chlorine (<1500ppm total Br + Cl) and <1000ppm antimony compounds.

Pin Assignments

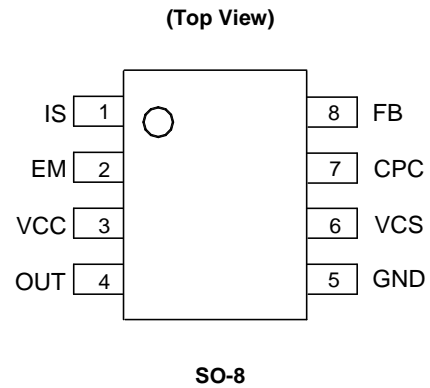

Applications

- Adapter/Chargers for Shaver, Cell/Cordless Phones, PDAs, MP3 and Other Portable Apparatus
- Standby and Auxiliary Power Supplies

Typical Applications Circuit

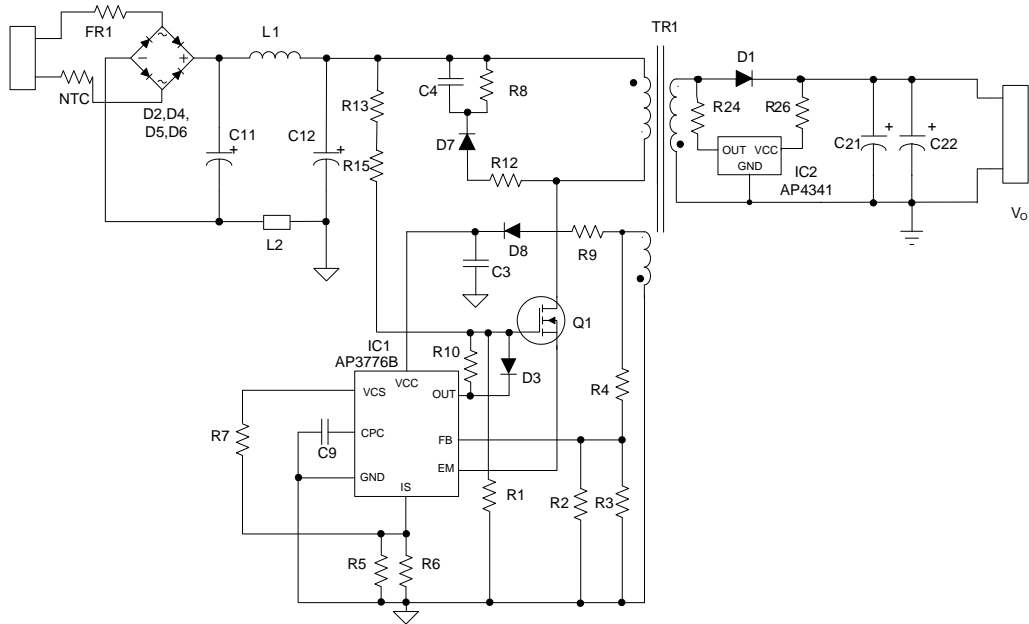

Typical Application of AP3776B with AP4341 ($V_{OUT} = 5V/1A$ or $2A$)

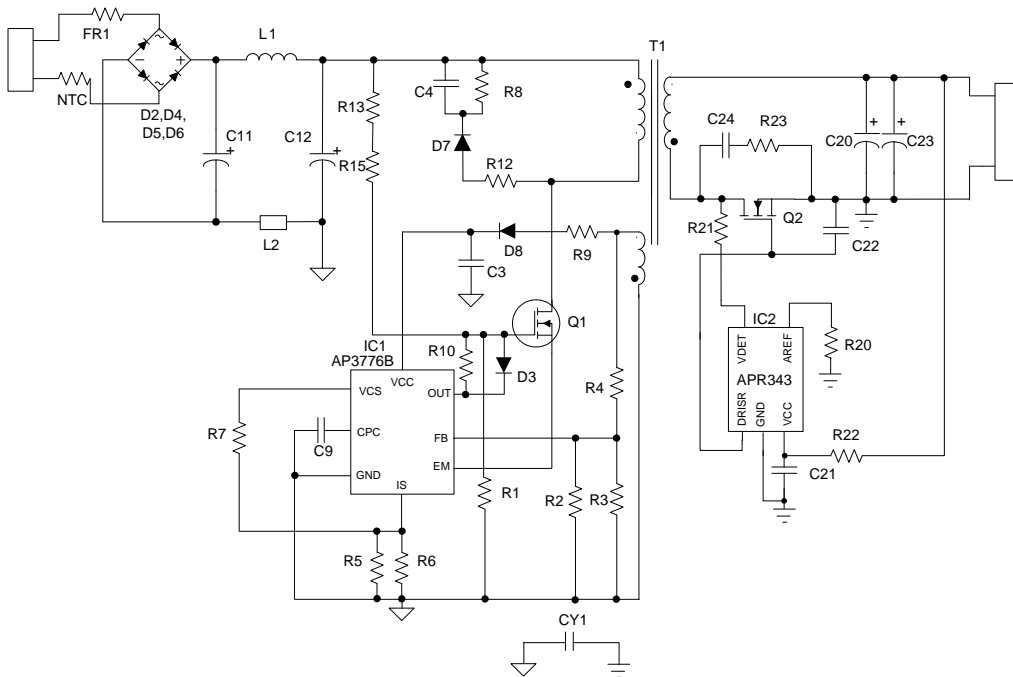

Typical Application of AP3776B with APR343 ($V_{OUT} = 5V/2A$ or $2.4A$)

NEW PRODUCT

Typical Applications Circuit (Cont.)

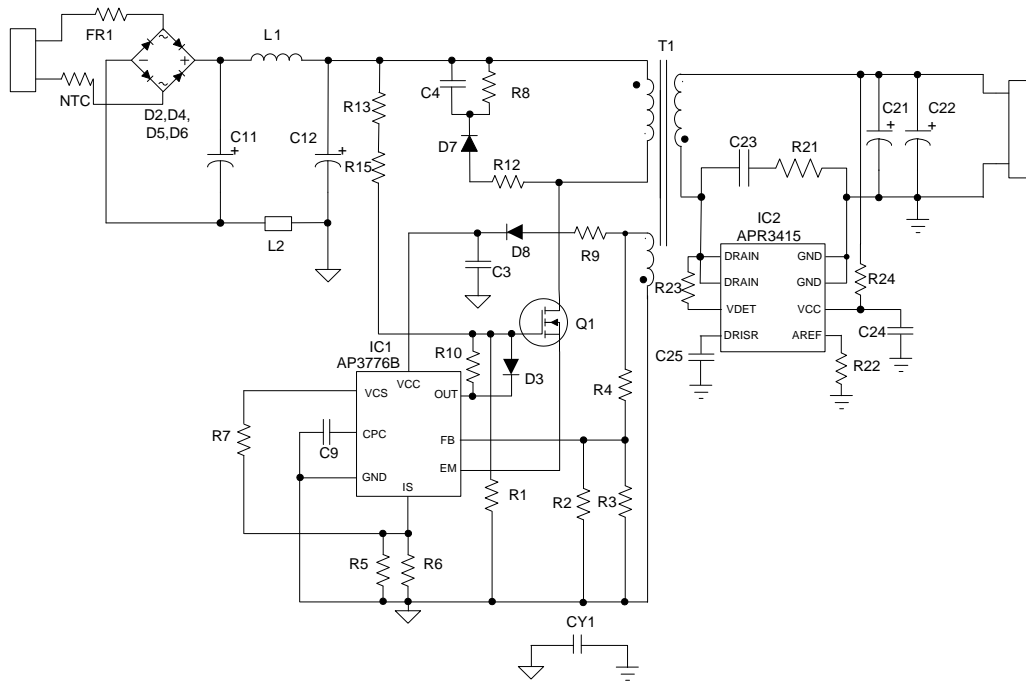

Typical Application of AP3776B with APR3415 ($V_{OUT} = 5V/2A$ or $2.4A$)

Pin Descriptions

Pin Number	Pin Name	Function
1	IS	Primary current sensing
2	EM	Connected to the source of external power MOSFET
3	VCC	Power supply
4	OUT	Driving the base of external power MOSFET
5	GND	Ground
6	VCS	Current sensing voltage
7	CPC	Connecting a capacitor for output cable compensation
8	FB	Voltage feedback

NEW PRODUCT

Functional Block Diagram

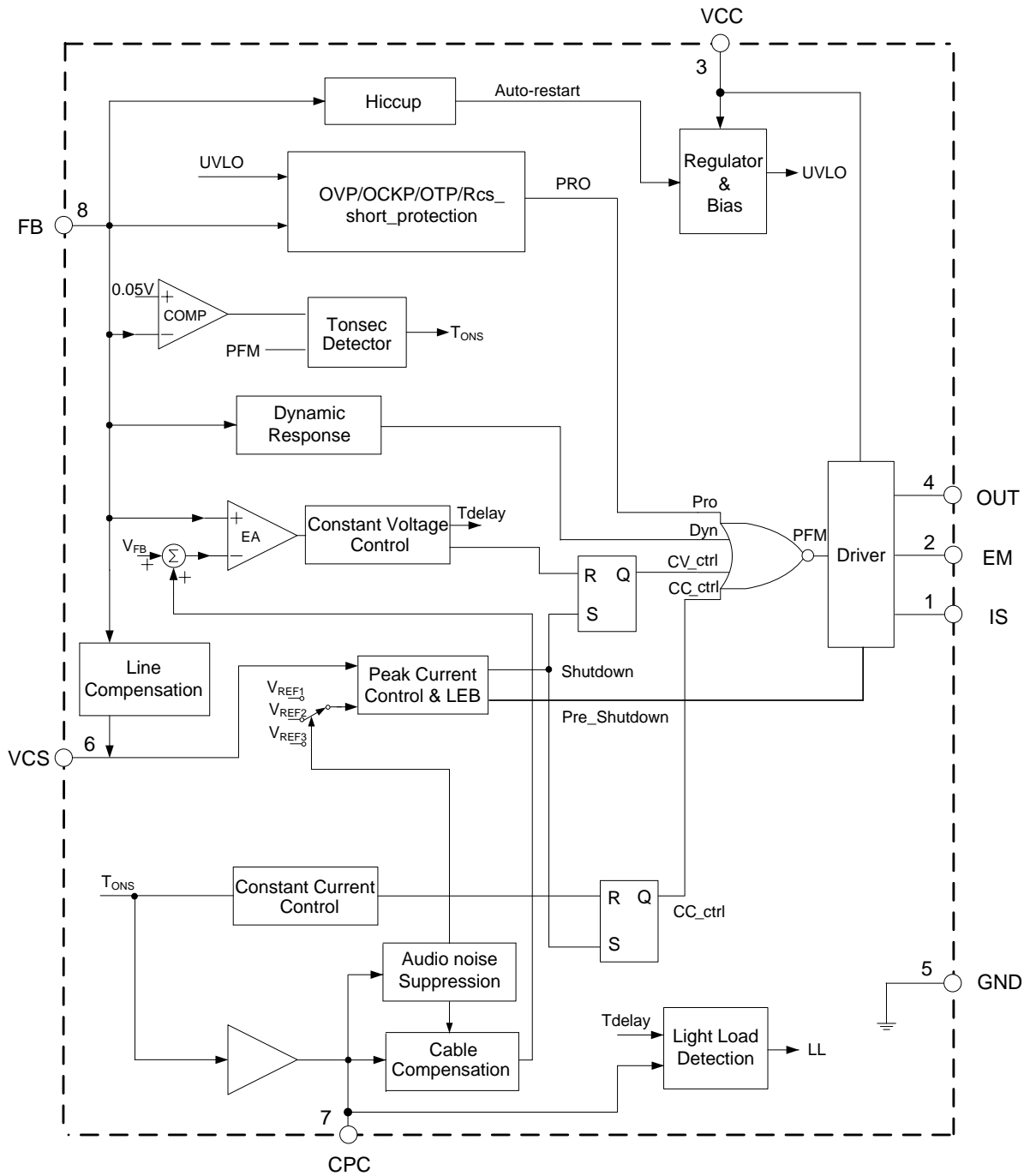

NEW PRODUCT

Absolute Maximum Ratings (Note 4)

Symbol	Parameter	Rating	Unit	
V _{CC}	Voltage at VCC to GND	-0.3 to 28	V	
–	Voltage at OUT, EM to GND	-0.3 to 23	V	
–	Voltage at IS, VCS, CPC to GND	-0.3 to 7	V	
–	FB Input	-40 to 10	V	
–	Output Current at OUT	Internally limited	A	
T _J	Operating Junction Temperature	+150	°C	
T _{STG}	Storage Temperature	-65 to +150	°C	
T _{LEAD}	Lead Temperature (Soldering, 10 Sec)	+300	°C	
θ _{JA}	Thermal Resistance Junction-to-Ambient	190	°C/W	
ESD	Electrostatic Discharge Capability	Human Body Model	6000	V
		Charged Device Model	2500	V
		Machine Model	200	V

Note 4: Stresses greater than those listed under “Absolute Maximum Ratings” may cause permanent damage to the device. These are stress ratings only, and functional operation of the device at these or any other conditions beyond those indicated under “Recommended Operating Conditions” is not implied. Exposure to “Absolute Maximum Ratings” for extended periods may affect device reliability.

Electrical Characteristics (@T_A = +25°C, V_{CC} = 15V, unless otherwise specified.)

Symbol	Parameter	Conditions	Min	Typ	Max	Unit
UVLO SECTION						
V _{TH} (ST)	Start-up Threshold	–	11	13	14	V
V _{OPR} (Min)	Minimal Operating Voltage	After turning on	5.3	6.1	7.0	
STANDBY CURRENT SECTION						
I _{ST}	Start-up Current	V _{CC} = V _{TH} (ST)-1V, Before turning on	0	0.2	0.6	µA
I _{CC} (STB)	Standby Mode Quiescent Current	No load at OUT pin, Standby Mode	60	100	130	
I _{CC} (QST)	Normal Mode Quiescent Current	No load at OUT pin, Normal Mode	160	280	330	
CURRENT SENSE SECTION						
V _{CS}	Current Sense Threshold (Note 5)	–	425	450	465	mV
t _{LEB}	Leading Edge Blanking (Note 6)	–	300	500	700	ns
FEEDBACK INPUT SECTION						
R _{FB}	Input Resistance of FB Pin	V _{FB} = 4V	0.5	0.7	0.9	MΩ
V _{FB}	Feedback Threshold Voltage	–	3.64	3.7	3.76	V
LINE COMPENSATION SECTION						
g _m	Line Compensation Transconductance (Note 7)	–	0.55	0.7	0.85	µS

Electrical Characteristics (Cont. @T_A = +25°C, V_{CC} = 15V, unless otherwise specified.)

Symbol	Parameter	Conditions	Min	Typ	Max	Unit
CABLE COMPENSATION SECTION						
V _{FB_CABLE} /V _{FB} %	Cable Compensation Voltage	–	2	3	4	%
DRIVE OUTPUT SECTION						
V _{GATE_CLAMP}	Gate Clamp Voltage	V _{CC} = 20V, C _L = 1nF	–	14	16	V
I _{SOURCE}	Source Current	–	55	67	80	mA
I _{SINK}	Sink Current	–	400	500	600	mA
t _{OFF} (MAX)	Maximum Off Time	–	15	19	30	ms
DYNAMIC FUNCTION SECTION						
t _D	Delay Time for Dynamic Function	–	100	140	220	μs
V _{TRIGGER}	Trigger Voltage for Dynamic Function	–	60	100	120	mV
PROTECTION SECTION						
tonp(MAX)	Maximum On Time of Primary Side	–	16	25	40	μs
V _{FB} (OVP)	Over Voltage Protection	–	6.5	7.5	8.5	V
V _{FB} (SCP)	Short Circuit Protection	–	2.38	2.50	2.62	V
–	Over Temperature Protection (Note 8)	Junction Temperature	+110	+130	+150	°C
–	Temperature Hysteresis (Note 8)	–	–	+20	–	°C

Notes: 5. V_{CS} is an equivalent parameter tested in closed loop to ensure the precise constant current.

6. The minimum power switch turn on time.

7. Line compensation voltage on CS pin: $\Delta V_{CS} = V_{IN_DC} \cdot \frac{N_{AUX}}{N_{PRI}} \cdot \frac{R_{17}}{R_{16} + R_{17}} \cdot g_m \cdot R_5$

8. Guaranteed by design.

Performance Characteristics

Start-up Threshold vs. Temperature

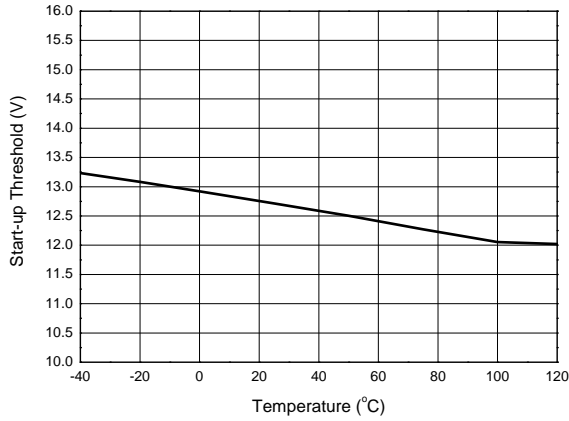

Start-up Current vs. Temperature

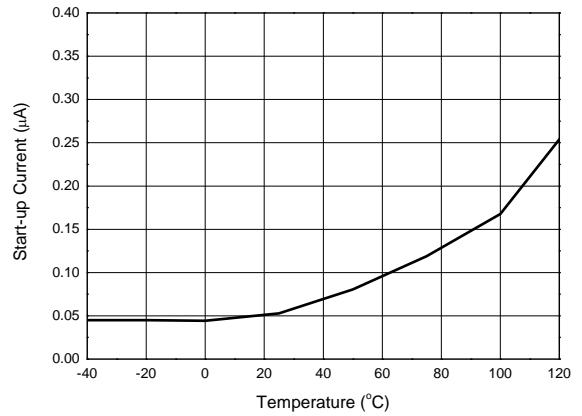

Minimal Operating Voltage vs. Temperature

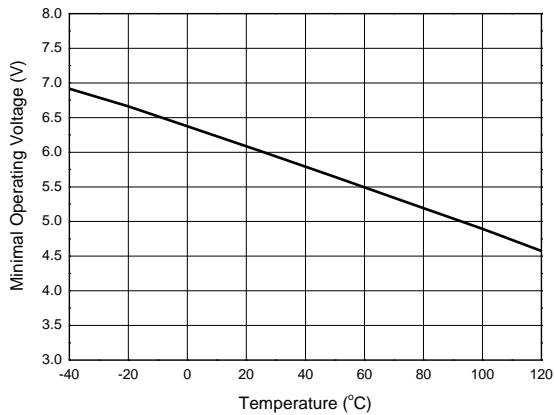

Standby Mode Quiescent Current vs. Temperature

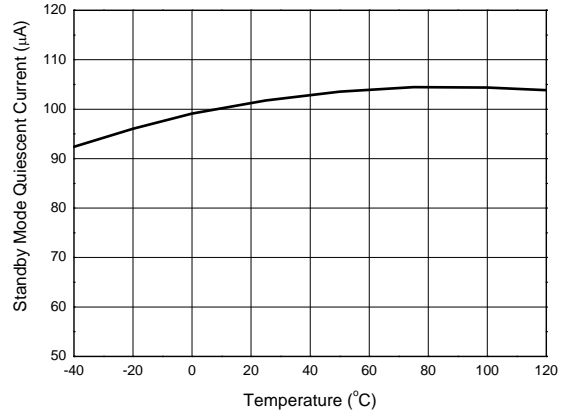

Normal Mode Quiescent Current vs. Temperature

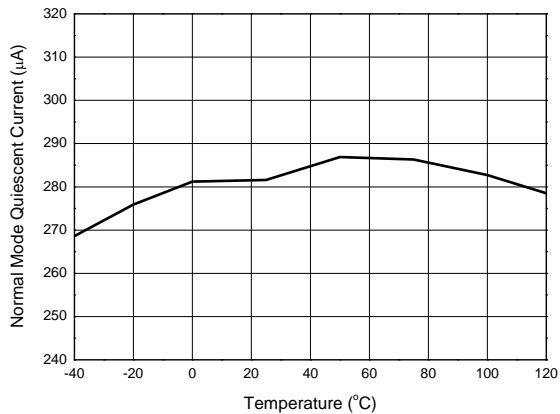

Function Description

Operation Description

1. Start-up Circuit

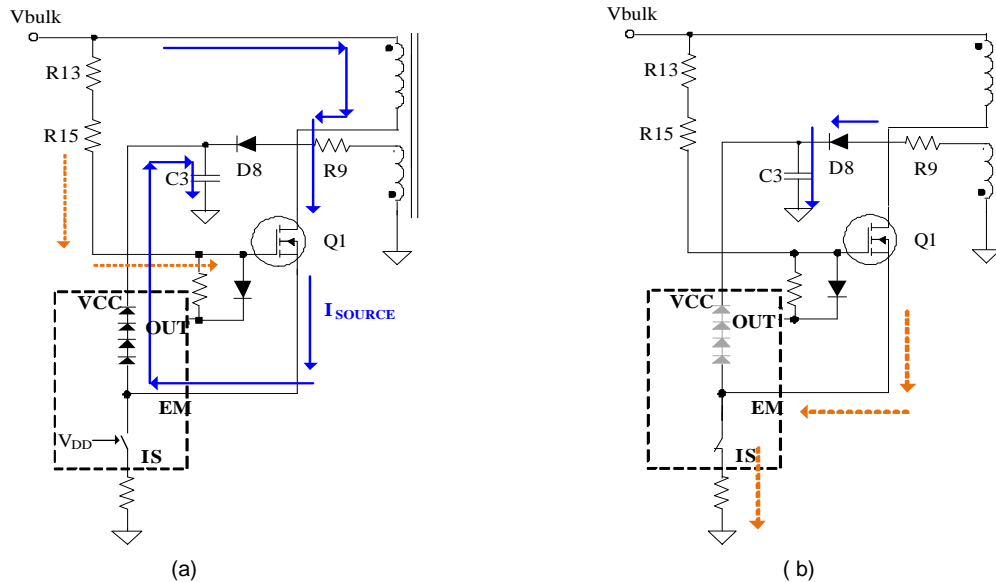

Figure 1. The AP3776B Start-up Circuit

Figure1 (a) shows the Startup Phase

- Before V_{CC} reaches $V_{TH}(ST)$, V_{DD} is zero and EM to IS pin is open.
- $C3$ is charged by I_{SOURCE} .
- The resistance of $R13$ and $R15$ should be big enough to reduce the power dissipation.

Figure1 (b) shows the Normal Operation Phase

- When V_{CC} reaches $V_{TH}(ST)$, V_{DD} is high and EM to IS pin is short.
- The voltage of EM pin is lower than 1V so that the four diodes in chip are open.
- $C3$ is supplied by Aux. winding of transformer.

2. Operation Mode

The typical application circuit of AP3776B is a conventional Flyback converter with a 3-winding transformer---primary winding (N_P), secondary winding (N_S) and auxiliary winding (N_{AUX}), as shown in the figure of Typical Application of AP3776B with AP4341. The auxiliary winding is used for providing V_{CC} supply voltage for IC and sensing the output voltage feedback signal to FB pin.

Figure 2 shows the typical waveforms which demonstrate the basic operating principle of AP3776B application. And the parameters are defined as following.

- I_P ---The primary side current
- I_S ---The secondary side current
- I_{PK} ---Peak value of primary side current
- I_{PKS} ---Peak value of secondary side current
- V_{SEC} ---The transient voltage at secondary winding
- V_S ---The stable voltage at secondary winding when rectification diode is in conducting status, which equals the sum of output voltage V_{OUT} and the forward voltage drop of diode
- V_{AUX} ---The transient voltage at auxiliary winding
- V_A --- The stable voltage at auxiliary winding when rectification diode is in conducting status, which equals the sum of voltage V_{CC} and the forward voltage drop of auxiliary diode
- t_{SW} ---The period of switching frequency
- t_{ONP} ---The conduction time when primary side switch is "ON"
- t_{ONS} ---The conduction time when secondary side diode is "ON"
- t_{OFF} ---The dead time when neither primary side switch nor secondary side diode is "ON"
- t_{OFFS} --- The time when secondary side diode is "OFF"

Function Description (Cont.)

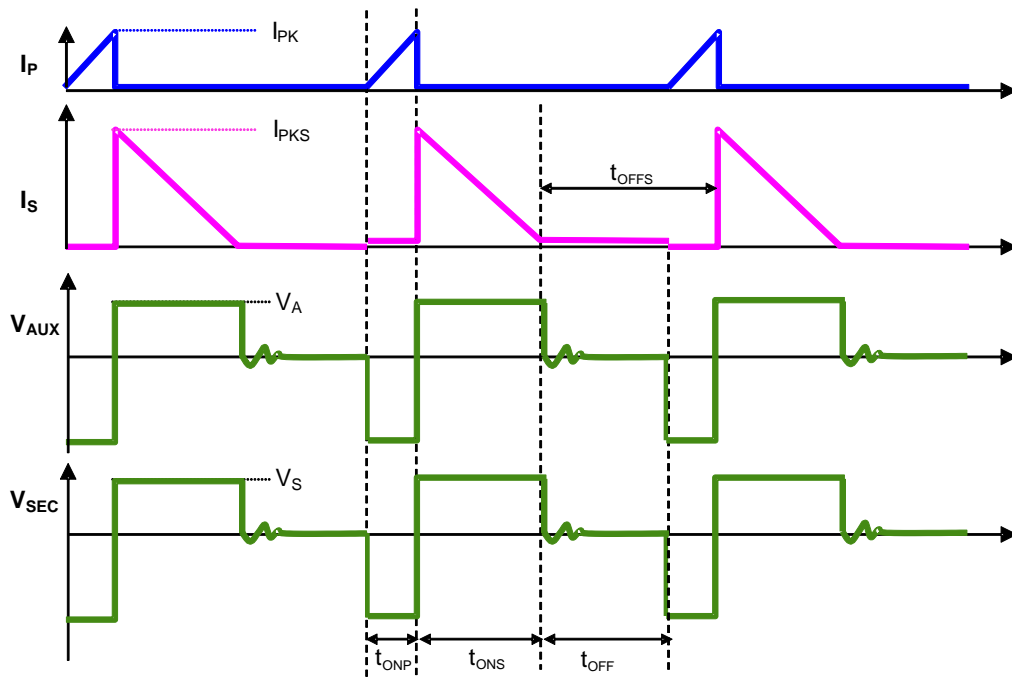

Figure 2. The Operation Waveform of Flyback PSR System

For primary-side regulation, the primary current $i_p(t)$ is sensed by a current sense resistor R_{CS} (R_5 , R_6 as shown in Typical Application of AP3776B). The current rises up linearly at a rate of:

$$\frac{di_p(t)}{dt} = \frac{V_{in}(t)}{L_M} \quad (1)$$

As illustrated in Figure 2, when the current $i_p(t)$ rises up to I_{PK} , the switch Q1 turns off. The constant peak current is given by:

$$I_{PK} = \frac{V_{CS}}{R_{CS}} \quad (2)$$

The energy stored in the magnetizing inductance L_M each cycle is therefore:

$$E_g = \frac{1}{2} \times L_M \cdot I_{PK}^2 \quad (3)$$

So the power transferring from the input to the output is given by:

$$P = \frac{1}{2} \times L_M \times I_{PK}^2 \times f_{SW} \quad (4)$$

Where, the f_{SW} is the switching frequency. When the peak current I_{PK} is constant, the output power depends on the switching frequency f_{SW} .

The maximum frequency for AP3776B system is about 84kHz.

Constant Voltage Operation

As to constant-voltage (CV) operation mode, the AP3776B detects the auxiliary winding voltage at FB pin to regulate the output voltage. The auxiliary winding voltage is coupled with secondary side winding voltage, so the auxiliary winding voltage at secondary rectification diode D1 conduction time is:

$$V_{AUX} = \frac{N_{AUX}}{N_S} \times (V_{OUT} + V_d) \quad (5)$$

Where the V_d is the diode forward voltage drop.

Function Description (Cont.)

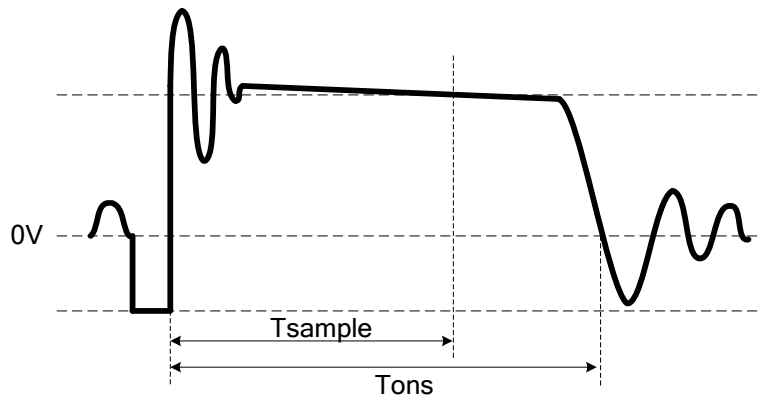

Figure 3. Auxiliary Voltage Waveform

The voltage detection point is at 2/3 of the D1 on-time. The voltage detection point is changed with the different primary peak current. The CV loop control function of AP3776B then generates a D1 off-time to regulate the output voltage.

Constant Current Operation

The AP3776B can work in constant-current (CC) mode. Figure 2 shows the secondary current waveforms.

In CC operation mode, the CC control loop of AP3776B will keep a fixed proportion between D1 on-time T_{ons} and D1 off-time T_{offs} . The fixed proportion is

$$\frac{T_{ons}}{T_{offs}} = \frac{4}{4} \tag{6}$$

The relationship between the output current and secondary peak current I_{PKS} is given by:

$$I_{OUT} = \frac{1}{2} \times I_{PKS} \times \frac{T_{ons}}{T_{ons} + T_{offs}} \tag{7}$$

As to tight coupled primary and secondary winding, the secondary peak current is

$$I_{PKS} = \frac{N_p}{N_s} \times I_{PK} \tag{8}$$

Thus the output constant-current is given by:

$$I_{OUT} = \frac{1}{2} \times \frac{N_p}{N_s} \times I_{PK} \times \frac{T_{ons}}{T_{ons} + T_{offs}} = \frac{2}{8} \times \frac{N_p}{N_s} \times I_{PK} \tag{9}$$

Therefore, AP3776B can realize CC mode operation by constant primary peak current and fixed diode conduction duty cycle.

Multiple Segment Constant Peak Current

As to the original PFM PSR system, the switching frequency decreases with output current decreasing, which will encounter audible noise issue since switching frequency decrease to audio frequency range, about less than 20kHz.

In order to avoid audible noise issue, AP3776B uses 3-segment constant primary peak current control method. At constant voltage mode, the current sense threshold voltage is multiple segments with different loading, as shown in Figure 4, which are V_{CS_H} for high load, V_{CS_M} for medium load and V_{CS_L} for light load. At constant current mode, the peak current is still V_{CS_H} . As to no load and ultra light load condition (LL mode), the current reference is also V_{CS_L} . But the LL mode operating is different, which will be described in next section.

It can be seen from the following Figure 4 that with multiple segment peak current control, AP3776B power system can keep switching frequency above 24kHz from light load to heavy load and guarantee the audible noise free performance.

Function Description (Cont.)

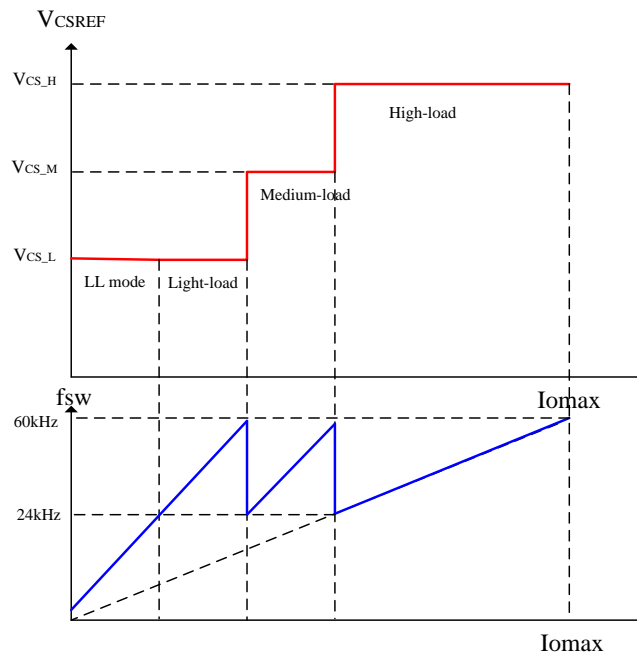

Figure 4. Multiple Segment Peak Current at CV Mode

3. The LL Mode Operating (Typical Application with APR343)

At no load and light load, the AP3776B works in Low Light mode (LL mode) and the output voltage is detected by APR343. In order to achieve ultra low standby power in LL mode, the static current (I_{CC_NL}) of the AP3776B is reduced from 280 μ A to 100 μ A.

- The conditions of exiting LL mode--- $V_{CPC} > 65mV$ or $t_{OFF} < t_{DELAY} + 30\mu s$
- The conditions of entering LL mode--- $V_{CPC} < 33mV$ and $t_{OFF} \geq t_{DELAY} + 30\mu s$

In LL mode, when the APR343 detects the output voltage is lower than its trigger voltage, the APR343 VDET pin emits a periodical pulse current. This pulse current will generate a pulse voltage on feedback winding through the transformer coupling. When the AP3776B detects this V_{PULSE} (>100mV is valid), primary switch immediately turns on to provide one energy pulse to supply output terminal and primary V_{CC} . To achieve low standby power, the lower switching frequency is necessary. But if the off time is too long, the V_{CC} voltage will reduce to very low level. To avoid V_{CC} being lower than $V_{OPR}(Min)$, a minimum switching frequency is specified by the APR343 (t_{DIS}). If V_{OUT} does not fall below trigger voltage during t_{DIS} , APR343 VDET pin will emit the periodical pulse current and let the primary switch turn on.

4. Leading Edge Blanking

When the power switch is turned on, a turn-on spike will occur on the sense-resistor. To avoid false-termination of the switching pulse, a 500ns leading-edge blanking (from power MOSFET on) is built in. During this blanking period, the current sense comparator is disabled and the gate driver can't be switched off.

5. Adjustable Line Compensation

Since there is a constant delay time from the CS pin voltage reaching the given V_{CS} reference to the power MOSFET turning off, the real primary peak current value always has a gap with the ideal value. The gap value changes with different input line voltage, which is caused by different current rising slope, results in different system constant current value.

In order to eliminate the constant current deviation due to line voltage, the adjustable line compensation is introduced to AP3776B design. By sensing the negative voltage of FB pin which is linear to the line voltage, a current (I_{LINE}) proportional to line voltage flows out from the CS pin to the resistor R_{LINE} , and create an adjustable compensation voltage to clear up the primary current gap, so that the excellent line regulation of output current will be achieved.

$$V_{CS_LINE} = R_{LINE} \cdot 0.4 \cdot \frac{1}{700k} \cdot \frac{R_{FB2}}{R_{FB1} + R_{FB2}} \cdot \frac{N_{aux}}{N_p} \cdot V_{indc}$$

Function Description (Cont.)

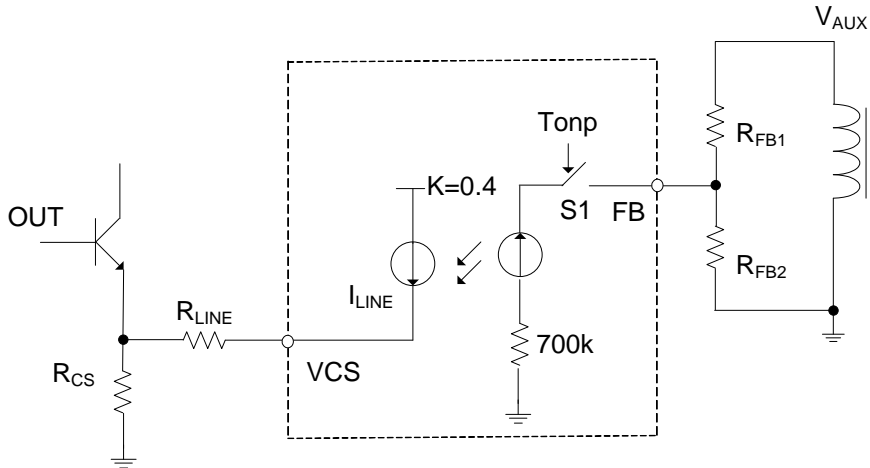

Figure 5. Adjustable Line Compensation Circuit

6. Fixed Cable Compensation

As we know, CPC voltage reflects the power system loading percentage. By introducing a rising voltage, which is linear to CPC voltage, to the FB reference voltage, AP3776B can realize the fixed cable compensation to match the voltage drop at output cable.

Protection

1. FB Over Voltage Protection (OVP)

When the voltage of FB pin exceeds $V_{FB(OVP)}$ at T_{ons} period, AP3776B immediately shuts down for $t_{OFF(MAX)}$ and then detects the FB voltage again to see if $V_{FB(OVP)}$ condition is removed. The V_{CC} voltage will drop during the $t_{OFF(MAX)}$. When V_{CC} is still higher than $V_{OPR(Min)}$ after $t_{OFF(MAX)}$, and $V_{FB(OVP)}$ condition is removed, the IC will enter normal operating mode; but if $V_{FB(OVP)}$ condition is not removed, AP3776B will remain shut down and wait for another $t_{OFF(MAX)}$. When V_{CC} drops to $V_{OPR(Min)}$ during the $t_{OFF(MAX)}$, AP3776B will enter the restart mode, and V_{CC} voltage changes between $V_{TH(ST)}$ and $V_{OPR(Min)}$ until $V_{FB(OVP)}$ condition is removed.

2. Open Circuit Protection (OCKP)

If the down resistance of FB pin short or up resistance open, there will be no voltage on FB pin, so the sample signal can't be monitored, and the OCKP protection will be triggered. The protection operating process is the same as over voltage protection process.

3. Short Circuit Protection (SCP)

Short Circuit Protection (SCP) detection principle is similar to the normal output voltage feedback detection by sensing FB pin voltage. When the detected FB pin voltage is below $V_{FB(SCP)}$ for a duration of about $t_{OFF(MAX)}$, the SCP is triggered. Then the AP3776B enters hiccup mode that the IC immediately shuts down and then restarts, so that the V_{CC} voltage changes between $V_{TH(ST)}$ and $V_{OPR(Min)}$ until $V_{FB(SCP)}$ condition is removed.

As to the normal system startup, the time duration of FB pin voltage below $V_{FB(SCP)}$ should be less than $t_{OFF(MAX)}$ to avoid entering SCP mode. But for the output short condition or the output voltage below a certain level, the SCP mode should happen.

Figure 6 shows the AP3776B normal start-up waveform. If the voltage of FB pin reaches above $V_{FB(SCP)}$ during $t_{OFF(MAX)}$ after V_{CC} gets to the $V_{TH(ST)}$, the IC doesn't enter the SCP mode. Figure 7 shows that V_{OUT} is short and the voltage of FB pin is lower than $V_{FB(SCP)}$ during $t_{OFF(MAX)}$, then the AP3776B triggers the SCP and enters the hiccup mode.

Function Description (Cont.)

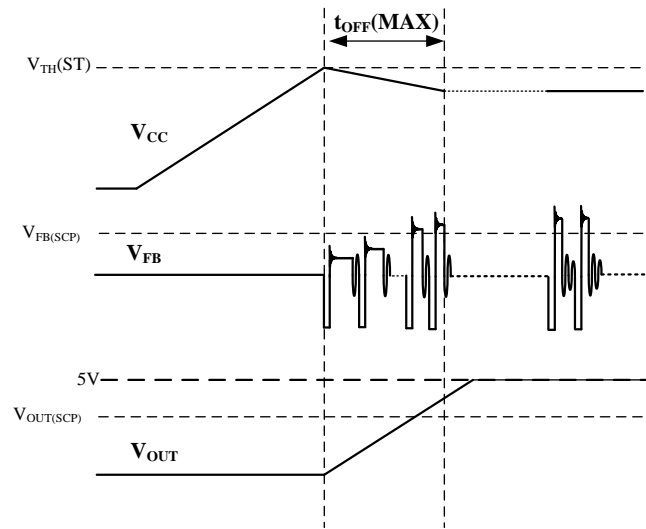

Figure 6. Normal Start-up

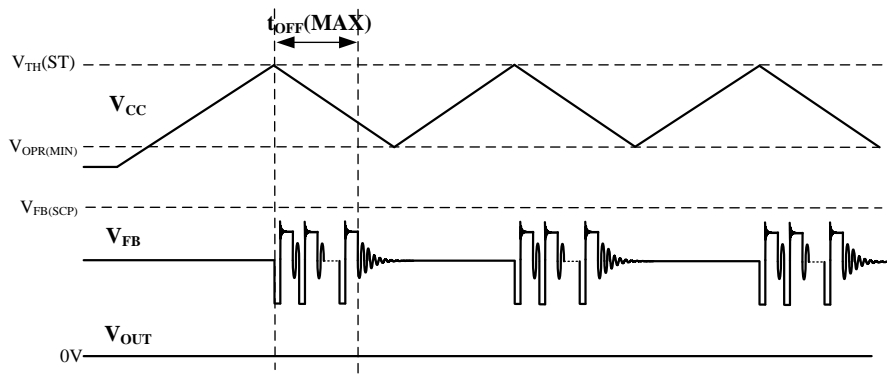

Figure 7. Short Circuit Protection (SCP) and Hiccup Mode

4. Rcs Short Protection

When the primary side current sense resistance is shorted, the primary side current rapidly increases, and the transformer saturates, which leads to some components' damage. The AP3776B draws in the Rcs short protection to avoid the damage. If the voltage of CS pin is smaller than 0.15V at the primary side maximum on time $t_{onp(MAX)}$, the Rcs short protection is triggered, and the AP3776B immediately shuts down, and then restarts.

5. Over Temperature Protection (OTP)

When the IC junction temperature exceeds the thermal shutdown temperature threshold of +130°C, the device shuts down immediately. Retry is allowed if junction temperature reduces by hysteresis temperature value.

Ordering Information

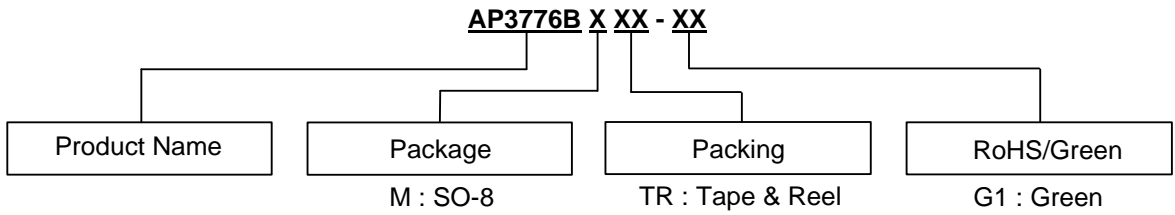

Package	Temperature Range	Part Number	Marking ID	Packing
SO-8	-40 to +85°C	AP3776BMTR-G1	3776BM-G1	4000/Tape & Reel

Marking Information

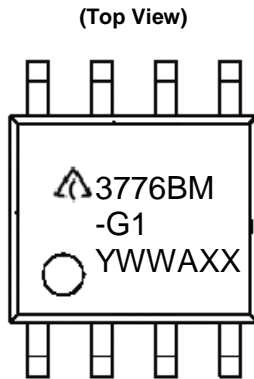

3776BM-G1: Marking ID
 Third Line: Date Code
 Y: Year
 WW: Work Week of Molding
 A: Assembly House Code
 XX: 7th and 8th Digits of Batch No.

Package Outline Dimensions (All dimensions in mm(inch).)

(1) Package Type: SO-8

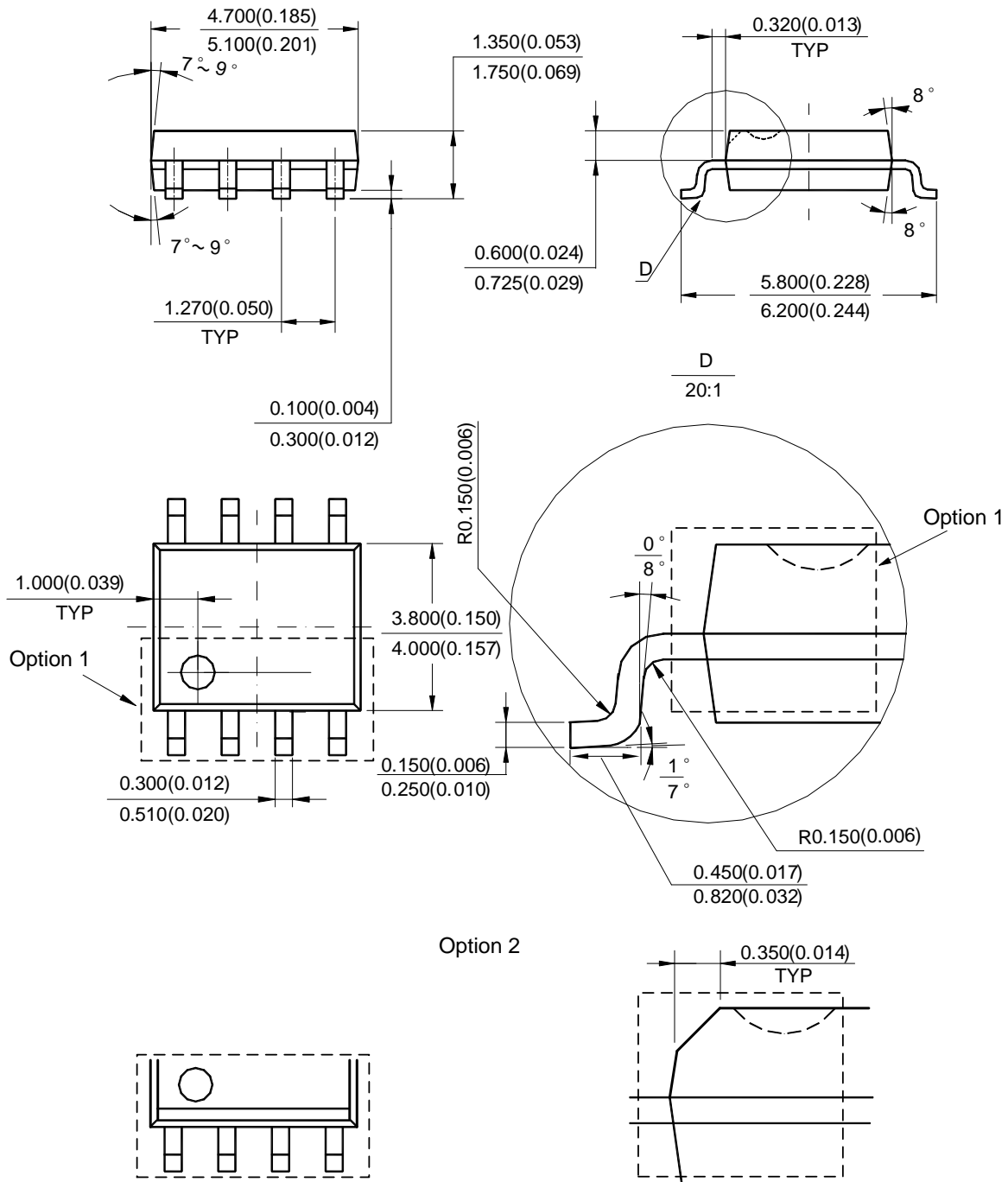

Note: Eject hole, oriented hole and mold mark is optional.

NEW PRODUCT

Suggested Pad Layout

(1) Package Type: SO-8

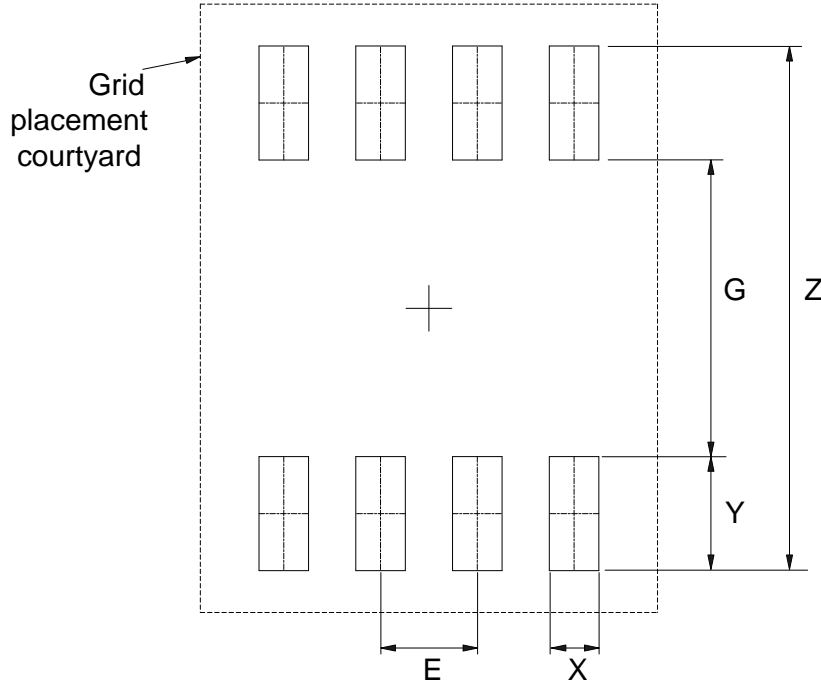

Dimensions	Z (mm)/(inch)	G (mm)/(inch)	X (mm)/(inch)	Y (mm)/(inch)	E (mm)/(inch)
Value	6.900/0.272	3.900/0.154	0.650/0.026	1.500/0.059	1.270/0.050

NEW PRODUCT

IMPORTANT NOTICE

DIODES INCORPORATED MAKES NO WARRANTY OF ANY KIND, EXPRESS OR IMPLIED, WITH REGARDS TO THIS DOCUMENT, INCLUDING, BUT NOT LIMITED TO, THE IMPLIED WARRANTIES OF MERCHANTABILITY AND FITNESS FOR A PARTICULAR PURPOSE (AND THEIR EQUIVALENTS UNDER THE LAWS OF ANY JURISDICTION).

Diodes Incorporated and its subsidiaries reserve the right to make modifications, enhancements, improvements, corrections or other changes without further notice to this document and any product described herein. Diodes Incorporated does not assume any liability arising out of the application or use of this document or any product described herein; neither does Diodes Incorporated convey any license under its patent or trademark rights, nor the rights of others. Any Customer or user of this document or products described herein in such applications shall assume all risks of such use and will agree to hold Diodes Incorporated and all the companies whose products are represented on Diodes Incorporated website, harmless against all damages.

Diodes Incorporated does not warrant or accept any liability whatsoever in respect of any products purchased through unauthorized sales channel. Should Customers purchase or use Diodes Incorporated products for any unintended or unauthorized application, Customers shall indemnify and hold Diodes Incorporated and its representatives harmless against all claims, damages, expenses, and attorney fees arising out of, directly or indirectly, any claim of personal injury or death associated with such unintended or unauthorized application.

Products described herein may be covered by one or more United States, international or foreign patents pending. Product names and markings noted herein may also be covered by one or more United States, international or foreign trademarks.

This document is written in English but may be translated into multiple languages for reference. Only the English version of this document is the final and determinative format released by Diodes Incorporated.

LIFE SUPPORT

Diodes Incorporated products are specifically not authorized for use as critical components in life support devices or systems without the express written approval of the Chief Executive Officer of Diodes Incorporated. As used herein:

A. Life support devices or systems are devices or systems which:

1. are intended to implant into the body, or
2. support or sustain life and whose failure to perform when properly used in accordance with instructions for use provided in the labeling can be reasonably expected to result in significant injury to the user.

B. A critical component is any component in a life support device or system whose failure to perform can be reasonably expected to cause the failure of the life support device or to affect its safety or effectiveness.

Customers represent that they have all necessary expertise in the safety and regulatory ramifications of their life support devices or systems, and acknowledge and agree that they are solely responsible for all legal, regulatory and safety-related requirements concerning their products and any use of Diodes Incorporated products in such safety-critical, life support devices or systems, notwithstanding any devices- or systems-related information or support that may be provided by Diodes Incorporated. Further, Customers must fully indemnify Diodes Incorporated and its representatives against any damages arising out of the use of Diodes Incorporated products in such safety-critical, life support devices or systems.

Copyright © 2015, Diodes Incorporated

www.diodes.com

Данный компонент на территории Российской Федерации

Вы можете приобрести в компании MosChip.

Для оперативного оформления запроса Вам необходимо перейти по данной ссылке:

<http://moschip.ru/get-element>

Вы можете разместить у нас заказ для любого Вашего проекта, будь то серийное производство или разработка единичного прибора.

В нашем ассортименте представлены ведущие мировые производители активных и пассивных электронных компонентов.

Нашей специализацией является поставка электронной компонентной базы двойного назначения, продукции таких производителей как XILINX, Intel (ex.ALTERA), Vicor, Microchip, Texas Instruments, Analog Devices, Mini-Circuits, Amphenol, Glenair.

Сотрудничество с глобальными дистрибьюторами электронных компонентов, предоставляет возможность заказывать и получать с международных складов практически любой перечень компонентов в оптимальные для Вас сроки.

На всех этапах разработки и производства наши партнеры могут получить квалифицированную поддержку опытных инженеров.

Система менеджмента качества компании отвечает требованиям в соответствии с ГОСТ Р ИСО 9001, ГОСТ РВ 0015-002 и ЭС РД 009

Офис по работе с юридическими лицами:

105318, г.Москва, ул.Щербаковская д.3, офис 1107, 1118, ДЦ «Щербаковский»

Телефон: +7 495 668-12-70 (многоканальный)

Факс: +7 495 668-12-70 (доб.304)

E-mail: info@moschip.ru

Skype отдела продаж:

moschip.ru

moschip.ru_4

moschip.ru_6

moschip.ru_9