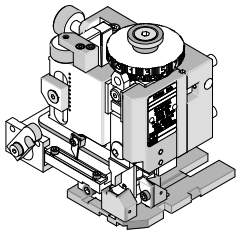

Mini-Mac Applicator		
	Application Tooling Specification Sheet	

FEATURES

- Directly adapts to most automatic wire processing machines
- Applicator designed to industry standard mounting and shut height 135.80mm (5.346")
- Quick set-up time; plus the crimp height, track and feed adjustments can be set without removing the applicator from the press
- Fine adjustment allows users to achieve target with little effort by adjusting in increments of .015mm (.0006") for conductor crimp height and .063mm (.0025") for insulation height
- Independent adjustment rings allow users to quickly adjust the conductor or insulation crimp height without affecting each other

SCOPE

Products: KK® High Pressure Crimp Terminal 22-30 AWG

Terminal Series No.	Terminal Order No.		Wire Size		Insulation Diameter		Strip Length	
			AWG	mm ²	mm	In.	mm	In.
7879	08-50-0004	50-29-1635	22-30	0.35-0.05	1.57 Max.	.062 Max.	2.54-3.17	.100-.125
	08-55-0124	50-29-1744						
	08-55-0128	50-29-1900						

DEFINITION OF TERMS

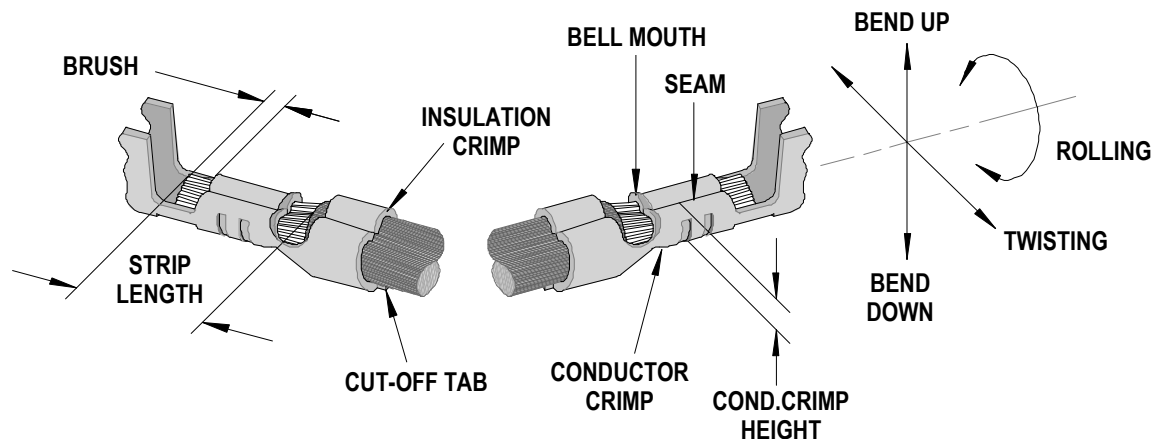

The above terminal drawing is a generic terminal representation. It is not an image of a terminal listed in the scope.

CRIMP SPECIFICATIONS

Terminal Series No.	Wire Size		Punch Width (Ref)				Seam Seam shall not be open and no wire allowed out of the crimping area
			Conductor		Insulation		
	AWG	mm ²	mm	In	mm	In	
7879	22-30	0.35-0.05	1.38	.054	1.65	.065	

After crimping, the conductor profile should measure the following.

Terminal Series No.	Wire Size		Conductor Crimp Height		Pull Force Minimum	
	AWG	mm ²	mm	In.	N	Lb.
7879	22	0.35	0.79-0.84	.031-.033	44.5	10.00
	24	0.20	0.73-0.79	.029-.031	35.6	8.00
	26	0.12	0.71-0.76	.028-.030	26.7	6.00
	28	0.08	0.68-0.73	.027-.029	17.8	4.00
	30	0.05	0.66-0.71	.026-.028	13.3	3.00

Tool Qualification Notes:

1. Pull Force should be measured with no influence from the insulation crimp.
2. The above specifications are guidelines to an optimum crimp.

PARTS LIST

Mini-Mac Applicator 63891-5100				
Item	Order No	Engineering No.	Description	Quantity
Perishable Tooling				
	63891-5170	63891-5170	Tool Kit (All "Y" Items)	REF
1	11-18-5256	60713D106	Conductor Punch	1 Y
2	11-18-5257	60713D107	Combination Anvil	1 Y
3	11-18-4180	60713-3	Insulation Punch	1 Y
4	11-18-4018	60704-6	Front Cut-Off Plunger	1 Y
5	11-18-4015	60704-3	Front Cut-off Plunger Retainer	1 Y
Other Components				
6	11-17-2152	7163-14	Hold Down Pad	1
7	11-17-2863	60633-23	Cut-off Plunger Spring	1
8	11-18-4021	60704-9	Front Cut-off Striker	1
9	11-18-4083	60707-8	Feed Guide	1
10	11-18-4181	60713-4	Tooling Washer	1
11	11-18-4187	60713-10	Terminal Hold Down Block	1
12	63443-0090	63443-0090	Wire Stop	1
13	63443-6111	63443-6111	Rear Cover	1
14	63803-5124	63803-5124	Conductor Bushing	1
Frame				
15	63801-3201	63801-3201	Top	1
16	63801-3282	63801-3282	Base	1
17	63801-6550	63801-6550	Track	1
Hardware				
18	N/A	N/A	M3 by 8 Long SHCS	2**
19	N/A	N/A	M4 by 6 Long SHCS	1**
20	N/A	N/A	M4 by 8 Long BHCS	1**
21	N/A	N/A	M4 by 12 Long BHCS	2**
22	N/A	N/A	M4 by 12 Long SHCS	2**
23	N/A	N/A	M5 by 10 Long SHCS	1**
24	N/A	N/A	M8 by 20 Long BHCS	1**
25	N/A	N/A	#6-32 by 3/8" Long BHCS	2**
26	N/A	N/A	#6-32 by 1/2" Long FHCS	1**
27	N/A	N/A	#6-32 Hex Jam Nut	1**
28	N/A	N/A	.078 Diameter by 3/8" Long Roll Pin	1**
** Available from an industrial supply company such as MSC (1-800-645-7270).				

Assembly Drawing

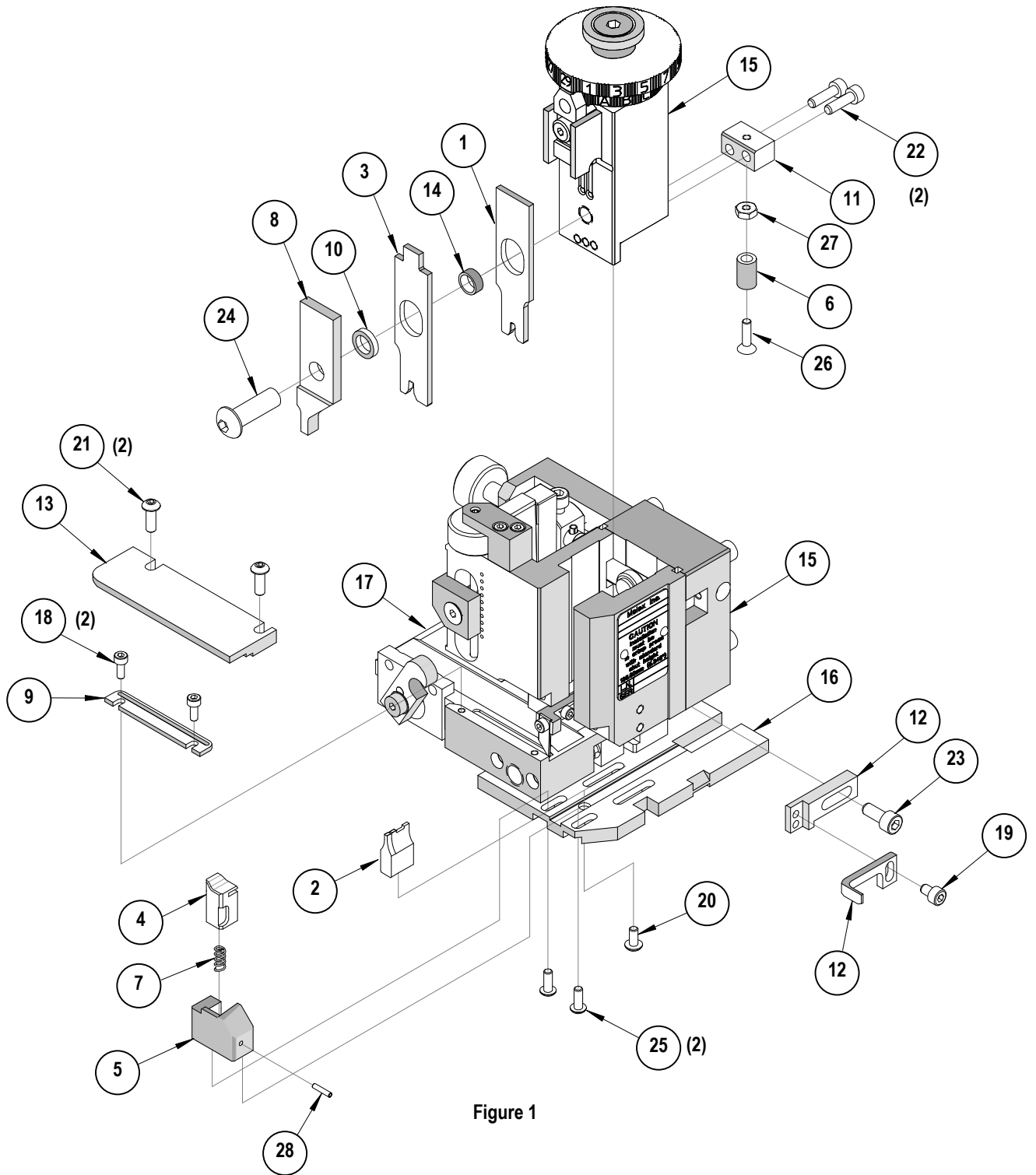

Figure 1

NOTES

1. Molex recommends an extra perishable tooling kit be maintained at your facility.
2. Verify tooling alignment by manually cycling the press and Applicator before crimping under power. Check that all screws are tight.
3. Slugs, Terminals, Dirt and Oil should be kept clear of work area.
4. Wear safety glasses at all times.
5. For recommended maintenance refer to the MiniMac Manual.

CAUTION: This applicator should only be used in a press with a shut height of 135.8 mm (5.346"). Tooling damage could result at a lower setting.

CAUTION: To prevent injury never operate this Applicator without the guards supplied with the press or wire-processing machine in place. Reference the press or wire processing manufacturer's instruction manual.

CAUTION: Molex crimp specifications are valid only when used with Molex terminals, applicators and tooling.

Visit our Web site at <http://www.molex.com>

Данный компонент на территории Российской Федерации

Вы можете приобрести в компании MosChip.

Для оперативного оформления запроса Вам необходимо перейти по данной ссылке:

<http://moschip.ru/get-element>

Вы можете разместить у нас заказ для любого Вашего проекта, будь то серийное производство или разработка единичного прибора.

В нашем ассортименте представлены ведущие мировые производители активных и пассивных электронных компонентов.

Нашей специализацией является поставка электронной компонентной базы двойного назначения, продукции таких производителей как XILINX, Intel (ex.ALTERA), Vicor, Microchip, Texas Instruments, Analog Devices, Mini-Circuits, Amphenol, Glenair.

Сотрудничество с глобальными дистрибьюторами электронных компонентов, предоставляет возможность заказывать и получать с международных складов практически любой перечень компонентов в оптимальные для Вас сроки.

На всех этапах разработки и производства наши партнеры могут получить квалифицированную поддержку опытных инженеров.

Система менеджмента качества компании отвечает требованиям в соответствии с ГОСТ Р ИСО 9001, ГОСТ РВ 0015-002 и ЭС РД 009

Офис по работе с юридическими лицами:

105318, г.Москва, ул.Щербаковская д.3, офис 1107, 1118, ДЦ «Щербаковский»

Телефон: +7 495 668-12-70 (многоканальный)

Факс: +7 495 668-12-70 (доб.304)

E-mail: info@moschip.ru

Skype отдела продаж:

moschip.ru

moschip.ru_4

moschip.ru_6

moschip.ru_9