

# "Auto" - Hard Wired (170 Series)

Line



## HARD WIRED LINE AUTOTRANSFORMERS

- Single winding, does not provide isolation, for use where equipment is already isolated and only voltage change is required.
- Flexible world wide applications, 50 or 60 Hz. operation, step down (230VAC to 115 VAC) or step up (115VAC to 230VAC).
- Connection by flexible leads, 8" minimum length.
- Models 170A, 170B, 170C & 170D are CSA certified (# LR 3902).
- **Remember** - These units do NOT convert line frequency.

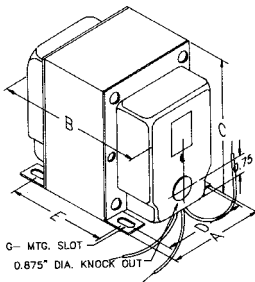

Part No.	Capacity VA	Dimensions (Inches)					Wt. Lbs.
		A	B	C	D	E	
170	50	2.19	2.63	2.63	1.75	1.56	2
170A	100	2.50	3.00	3.06	2.00	1.94	3
170B	200	3.13	3.50	3.81	2.50	2.19	4.5
170C	300	3.13	4.00	3.81	2.50	2.69	6
170D	500	3.75	4.50	4.56	3.00	3.31	10
170E	750	3.75	5.50	4.56	3.00	4.31	14
170F	1000	3.75	5.50	4.56	3.00	4.31	14.5
170G	1500	4.38	6.63	5.30	3.50	5.10	22
170J	2000	4.38	6.63	5.25	3.50	5.10	23

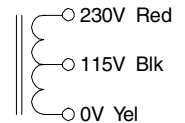

## HARD WIRED LINE AUTOTRANSFORMERS

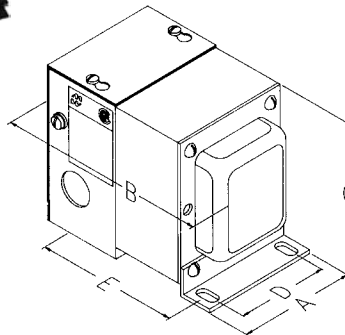

- Single winding, does not provide isolation, for use where equipment is already isolated and only voltage change is required.
- Flexible world wide applications, 50 or 60 Hz. operation, step down (230VAC to 115 VAC) or step up (115VAC to 230VAC).
- Totally enclosed rear case, includes handy internal grounding bolt.
- Extra vacuum varnish for use in high humidity.
- Includes a rear mounted (but not wired), standard 115VAC, 3-wire receptacle.
- Enclosed case with convenient knockouts and includes two cable clamps allowing for easy wire connections.
- Models 170SE, 170AE, 170BE, 170CE & 170DE are CSA certified (# LR3902)
- Connection by flexible leads, 8" minimum length
- **Remember** - These units do NOT convert line frequency.

Part No.	Capacity VA	Dimensions (Inches)					Wt. Lbs.
		A	B	C	D	E	
170SE	50	3.13	4.00	4.13	2.25	3.13	3.5
170AE	100	3.13	4.00	4.13	2.25	3.13	4
170BE	200	3.13	4.25	4.13	2.25	3.38	5
170CE	300	3.13	4.75	4.13	2.25	3.88	6.5
170DE	500	3.75	5.00	4.88	2.75	4.13	10
170EE	750	3.75	6.00	4.88	2.75	5.13	15
170FE	1000	3.75	6.00	4.88	2.75	5.13	15.5
170GE	1500	4.38	7.00	5.50	3.25	5.88	23.5
170JE	2000	4.38	7.00	5.50	3.25	5.88	24.0

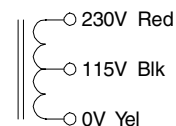

**CANADA**  
Guelph, Ontario (519) 822-2960  
St. Laurent, Quebec (514) 343-9010  
**USA**  
Cheektowaga, NY (716) 630-7030

[www.hammondmfg.com](http://www.hammondmfg.com)



**EUROPE**  
Basingstoke, UK 01256 812812

**AUSTRALIA**  
Queenstown, Australia 61-8-8240-2244

# "Auto" - Hard Wired (168 Series)



## HARD WIRED LINE AUTOTRANSFORMERS

- Single winding, does not provide isolation, for use where equipment is already isolated and only voltage change is required.
- Flexible world wide applications, 50 or 60 Hz. operation, 115VAC input.
- Output taps @ 85, 95, 105, 110, 115 and 125VAC.
- Ideal for manual line voltage adjustment for electronic equipment or small appliance operation.
- Models 168B, 168C & 168D are CSA certified (# LR3902)
- Connection by flexible leads, 8" minimum length.
- **Remember** - These units do NOT convert line frequency.

Part No.	Capacity VA	Dimensions (Inches)					Wt. Lbs.
		A	B	C	D	E	
168B	200	3.13	3.25	3.81	2.50	1.94	4.3
168C	350	3.13	4.00	3.81	2.50	2.69	6.5
168D	500	3.75	4.00	4.56	3.00	2.81	8
168E	750	3.75	4.50	4.56	3.00	3.31	10
168F	1000	3.75	5.50	4.56	3.00	4.31	14
168H	1500	4.38	6.13	5.25	3.50	4.50	20
168J	2000	4.38	6.63	5.25	3.50	5.10	23

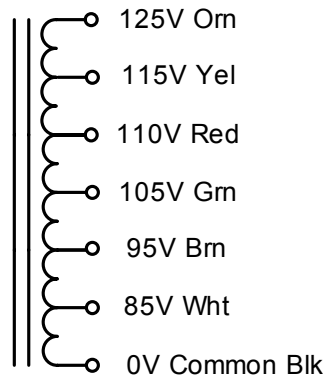

Line

### EUROPE

Basingstoke, UK 01256 812812

### AUSTRALIA

Queenstown, Australia 61-8-8240-2244

[www.hammondmfg.com](http://www.hammondmfg.com)



### CANADA

Guelph, Ontario (519) 822-2960  
St. Laurent, Quebec (514) 343-9010

### USA

Cheektowaga, NY (716) 630-7030



## Данный компонент на территории Российской Федерации

### Вы можете приобрести в компании MosChip.

Для оперативного оформления запроса Вам необходимо перейти по данной ссылке:

<http://moschip.ru/get-element>

Вы можете разместить у нас заказ для любого Вашего проекта, будь то серийное производство или разработка единичного прибора.

В нашем ассортименте представлены ведущие мировые производители активных и пассивных электронных компонентов.

Нашей специализацией является поставка электронной компонентной базы двойного назначения, продукции таких производителей как XILINX, Intel (ex.ALTERA), Vicor, Microchip, Texas Instruments, Analog Devices, Mini-Circuits, Amphenol, Glenair.

Сотрудничество с глобальными дистрибьюторами электронных компонентов, предоставляет возможность заказывать и получать с международных складов практически любой перечень компонентов в оптимальные для Вас сроки.

На всех этапах разработки и производства наши партнеры могут получить квалифицированную поддержку опытных инженеров.

Система менеджмента качества компании отвечает требованиям в соответствии с ГОСТ Р ИСО 9001, ГОСТ РВ 0015-002 и ЭС РД 009

### Офис по работе с юридическими лицами:

105318, г.Москва, ул.Щербаковская д.3, офис 1107, 1118, ДЦ «Щербаковский»

Телефон: +7 495 668-12-70 (многоканальный)

Факс: +7 495 668-12-70 (доб.304)

E-mail: [info@moschip.ru](mailto:info@moschip.ru)

Skype отдела продаж:

moschip.ru

moschip.ru\_4

moschip.ru\_6

moschip.ru\_9