

Main

Range of product	Magelis STO & STU
Product or component type	Touch panel screen
Software designation	Vijeo Designer
Operating system	Magelis
Processor name	CPU RISC

Complementary

Display size	3.4 inch
Display type	Backlit monochrome STN LCD
Background colour	White, pink and red
Display resolution	200 x 80 pixels
Touch panel	Analogue
Backlight lifespan	10000 hours with red 50000 hours with pink 50000 hours with white
Brightness	8 levels
Contrast	16 levels via touch panel
Character font	ASCII Chinese (simplified Chinese) Japanese (ANK, Kanji) Korean Taiwanese (traditional Chinese)
[Us] rated supply voltage	24 V DC +/- 20 %
Inrush current	30 A
Local signalling	1 LED with green for normal operation
Power consumption in W	5 W
Number of pages	Limited by internal memory capacity
Processor frequency	333 MHz
Memory description	Application memory, 16 MB Back up of data, 128 kB
Integrated connection type	1 USB 2.0 type mini B 1 USB 2.0 type A Removable screw terminal block connector power supply 9-pin terminal block connector serial link with RS232C interface
Supply	External source
Realtime clock	Access to the PLC real-time clock
Downloadable protocols	Zelio
Range compatibility	Zelio Logic
Fixing mode	By 2 spring clips on 1.6...5 mm thick panel
Enclosure material	PPT
Marking	CE

Environment

immunity to microbreaks	3 ms
standards	EN 61131-2 FCC Class A IEC 61000-6-2 UL 1604

The information provided in this documentation contains general descriptions and/or technical characteristics of the performance of the products contained herein. This documentation is not intended as a substitute for and is not to be used for determining suitability or reliability of these products for specific user applications. It is the duty of any such user or integrator to perform the appropriate and complete risk analysis, evaluation and testing of the products with respect to the relevant specific application or use thereof. Neither Schneider Electric Industries SAS nor any of its affiliates or subsidiaries shall be responsible or liable for misuse of the information contained herein.

UL 508

product certifications	CE C-Tick CULus UL Class 1 Division 2 T4A UL Class 1 Division 2 T5
ambient air temperature for operation	32...122 °F (0...50 °C)
ambient air temperature for storage	-4...140 °F (-20...60 °C)
relative humidity	0...90 % without condensation
operating altitude	<= 6561.68 ft (2000 m)
IP degree of protection	IP20 (rear panel) conforming to IEC 60529 IP65 (front panel) conforming to IEC 60529
NEMA degree of protection	NEMA 4X front panel (indoor use)
shock resistance	15 gn 11 ms conforming to IEC 60068-2-27
vibration resistance	+/- 3.5 mm (f = 5...9 Hz) conforming to IEC 60068-2-6 1 gn (f = 9...150 Hz) conforming to IEC 60068-2-6
electromagnetic compatibility	Resistance to radiated electromagnetic fields : 10 V/m conforming to IEC 61000-4-3

Offer Sustainability

Not Green Premium product	Not Green Premium product
Compliant - since 1113 - Schneider Electric declaration of conformity	Compliant - since 1113 - Schneider Electric declaration of conformity
Reference not containing SVHC above the threshold	Reference not containing SVHC above the threshold
WARNING: Cancer and Reproductive Harm - www.P65Warnings.ca.gov	WARNING: Cancer and Reproductive Harm - www.P65Warnings.ca.gov

Contractual warranty

Warranty period	18 months
-----------------	-----------

Dimensions with Spring Clips

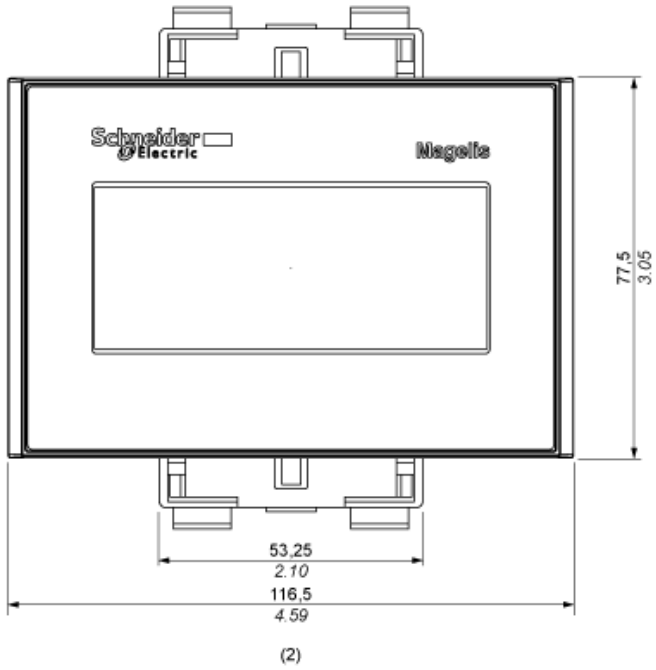
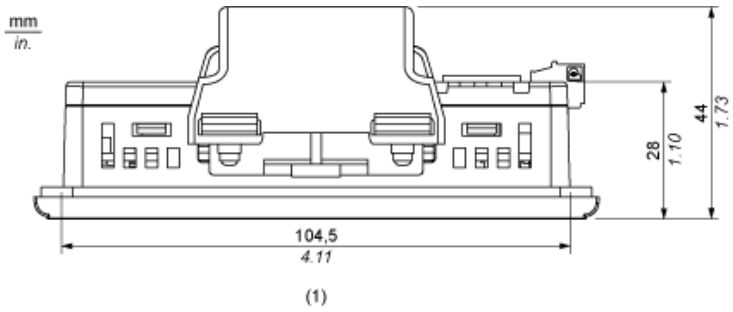

- (1) Top
- (2) Front

Dimensions without Spring Clips

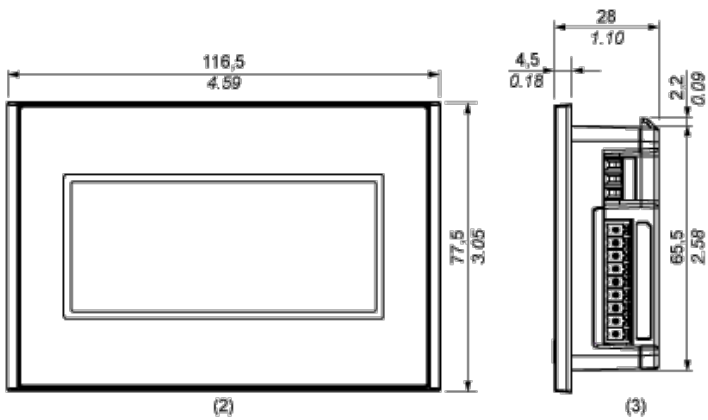
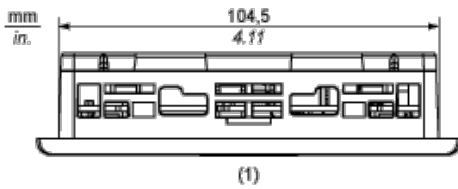

- (1) Top
- (2) Front
- (3) Right Side

Clearance

mm
in.

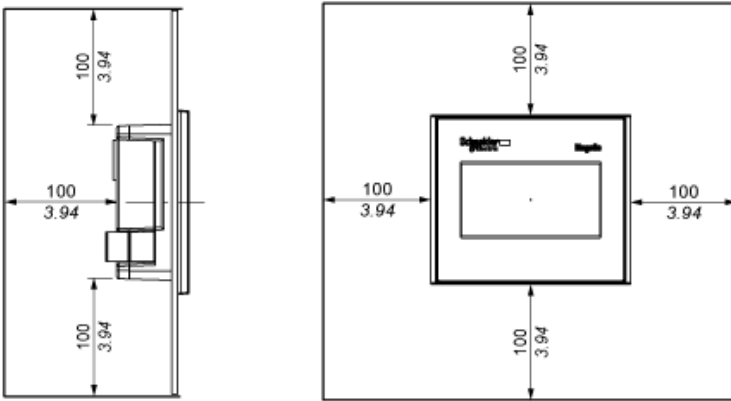

Panel Cut-out Dimensions

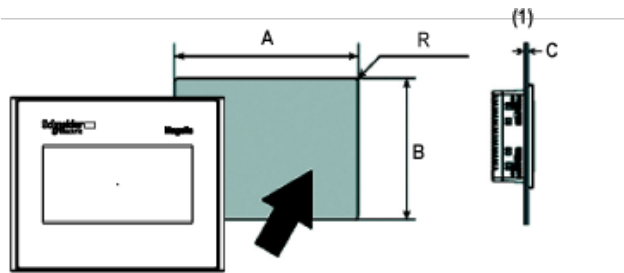

(1) Panel

A (mm)	A (in.)	B (mm)	B (in.)	C (mm) Spring Clips	C (in.) Spring Clips	R (mm)	R (in.)
+1	+0.04	+1	+0.04	1.5 to 6.0	0.059 to 0.236	2.0 to 3.0	0.078 to 0.118
105	4.13	66	2.59				
-0	-0	-0	-0				

Данный компонент на территории Российской Федерации

Вы можете приобрести в компании MosChip.

Для оперативного оформления запроса Вам необходимо перейти по данной ссылке:

<http://moschip.ru/get-element>

Вы можете разместить у нас заказ для любого Вашего проекта, будь то серийное производство или разработка единичного прибора.

В нашем ассортименте представлены ведущие мировые производители активных и пассивных электронных компонентов.

Нашей специализацией является поставка электронной компонентной базы двойного назначения, продукции таких производителей как XILINX, Intel (ex.ALTERA), Vicor, Microchip, Texas Instruments, Analog Devices, Mini-Circuits, Amphenol, Glenair.

Сотрудничество с глобальными дистрибьюторами электронных компонентов, предоставляет возможность заказывать и получать с международных складов практически любой перечень компонентов в оптимальные для Вас сроки.

На всех этапах разработки и производства наши партнеры могут получить квалифицированную поддержку опытных инженеров.

Система менеджмента качества компании отвечает требованиям в соответствии с ГОСТ Р ИСО 9001, ГОСТ РВ 0015-002 и ЭС РД 009

Офис по работе с юридическими лицами:

105318, г.Москва, ул.Щербаковская д.3, офис 1107, 1118, ДЦ «Щербаковский»

Телефон: +7 495 668-12-70 (многоканальный)

Факс: +7 495 668-12-70 (доб.304)

E-mail: info@moschip.ru

Skype отдела продаж:

moschip.ru

moschip.ru_4

moschip.ru_6

moschip.ru_9